



System i and System p

Installing the rack, rack features, and system or expansion unit into a rack





System i and System p

Installing the rack, rack features, and system or expansion unit into a rack

Note

Before using this information and the product it supports, read the information in “Notices” on page 183 and the *IBM Systems Safety Information* manual, G229-9054.

Twelfth Edition (September 2007)

© Copyright International Business Machines Corporation 2004, 2007.

US Government Users Restricted Rights – Use, duplication or disclosure restricted by GSA ADP Schedule Contract with IBM Corp.

Contents

Safety and environmental notices	vii
About this topic	xi
Installing racks, rack features, and systems or expansion units	1
Rack Safety Notices	1
Completing a parts inventory.	3
Installing the rack	3
Installing the 7014-T00, 7014-T42, 0551, or 0553 racks	3
Completing a parts inventory.	3
Positioning the rack	4
Leveling the rack	4
Attaching the stabilizer brackets	5
Attaching the rack to a concrete floor	6
Attaching the rack to the concrete floor beneath a raised floor	11
Connecting the power distribution system	15
Checking the ac outlets	15
Attaching the front or back ac electrical outlet.	16
Installing the ac outlet-mounting plates with ac outlets	16
Installing the ac outlet-mounting plate without ac outlets	18
Connecting a dc power source	19
Installing the 7014-S11 rack	22
Installing the 7014-S25 rack	24
Removing and replacing 7014-S25 doors.	26
Installing a 7014-S25 front door.	26
Removing and replacing 7014-S25 side panels	26
Replacing a 7014-S25 side panel	27
Installing the cage nuts in a 7014-S25 or 7014-S11 rack	28
Installing rack features	29
Attaching the rack doors	29
Removing and replacing 7014-T00, 7014-T42, 0551, or 0553 side panels	30
Replacing a 7014-T00, 7014-T42, 0551, or 0553 side panel	31
Attaching a pSeries rack front door	32
Attaching an RS/6000 or high-perforation front door	32
Installing the Rear Door Heat Exchanger for 7014-T42	34
Attaching the Heat Exchanger assembly to the rack	36
Connecting the water supply	38
Filling the Heat Exchanger with water	40
Completing the installation of the Heat Exchanger	42
Heat Exchanger maintenance procedures	44
Purging air from the Heat Exchanger.	45
Draining the Heat Exchanger	46
Refilling after a leak in the system.	49
Replacing the Heat Exchanger door	51
Heat Exchanger common procedures	52
Heat Exchanger maintenance schedule	56
Installing the rack security kit	56
Ruggedized kit	60
Releasing the ruggedized brace.	61
Releasing the side panel with a ruggedized kit	61
Connecting multiple racks with rack-to-rack attachment kit	62
Rack status beacon	64
Installing the rack status beacon	64
Connecting multiple junction boxes	66
Installing or removing a rack-mounted system-unit latch bracket	67

Power distribution unit plus (PDU+)	69
Installing the PDU+ in the side of a rack	69
Installing the PDU+ horizontally in a rack	71
Setting up power monitoring using the PDU+	75
Using the IBM DPI Configuration Utility	75
Using the Web interface	77
Installing a system or expansion unit into a rack	79
Installing the model 505 or 9115-505 into a rack	79
Determining the location	81
Marking the location without a rack-mounting template	82
Installing the slide-rail kit into the rack	82
Installing the slide rails into the rack	82
Installing the system unit on the slide rails	86
Installing the cable-management arm	88
Installing the fixed-rail kit to the rack	90
Attaching the mounting hardware to the rack	91
Attaching the mounting hardware to a tapped-hole rack	93
Installing the cable-management arm	94
Installing the system unit on the rail assembly	94
Installing the 51x, 710, or 9110-51A into a rack	97
Determining the location	97
Marking the location using a rack-mounting template	98
Marking the location without a rack-mounting template	100
Attaching the mounting hardware to the rack	100
Installing the system on the rail assembly	102
Installing the cable-management arm	103
Installing the 515 or 52x into a rack	104
Converting the stand-alone model 520 for rack installation	106
Preparing the stand-alone 52x	107
Determining the location	111
Marking the location using a rack-mounting template	112
Marking the location without a rack-mounting template	114
Attaching the mounting hardware to the rack	114
Installing the system unit onto the rail assembly	116
Installing the cable-management arm	119
Installing the model 55x, 9113-550, or OpenPower 720 in a rack	120
Determining the location	122
Marking location using the rack-mounting template	123
Marking the location without a rack-mounting template	124
Attaching the mounting hardware to the rack	125
Installing the system unit on the rail assembly	127
Installing the cable-management arm	130
Installing the model 7037-A50 into a rack	131
Determining the location	133
Marking the location using the rack-mounting template	134
Marking the location without a rack-mounting template	136
Attaching the mounting hardware to the rack	137
Installing the cable-management arm	138
Installing the system unit on the rail assembly	139
Installing the model 7031-D24 into a rack	143
Determining the location	144
Marking the location using rack-mounting template	145
Marking the location without a rack-mounting template	147
Attaching the mounting hardware to the rack	148
Installing the 7031-D24 on the rail assembly	149
Installing the 5088 or 0588 expansion unit into a rack	151
Installing the 5095, 0595, or 7311-D20 expansion unit into a rack	153
Attaching the cable-management arm to the standard rails	154
Determining the location	155
Marking the location using a rack-mounting template	156
Marking the location without a rack-mounting template	158

Installing the 5095, 0595, or 7311-D20 rails into the rack	158
Installing the 5095, 0595, or 7311-D20 expansion unit into a rack	160
Installing the 5790 or 7311-D11 expansion unit in a rack	163
Powering off the system and removing power	165
Marking the location using the rack-mounting template	165
Marking the location without a rack-mounting template	167
Installing the standard rails.	169
Installing the expandable rails and extension bracket into the rack	169
Installing the shell.	172
Installing the system	175
Attaching the RIO/HSL, power controller (SPCN), and power cables.	176
Powering on the system.	177
Related information	177
Determine power cord, plug, and receptacle type	177
Reconnecting cables to the system	178
Connecting drawer and device cables	179
Appendix. Accessibility features	181
Notices	183
Trademarks	184
Electronic emission notices	184
Class A Notices.	184
Class B Notices.	188

Safety and environmental notices

Safety notices may be printed throughout this guide:

- **DANGER** notices call attention to a situation that is potentially lethal or extremely hazardous to people.
- **CAUTION** notices call attention to a situation that is potentially hazardous to people because of some existing condition.
- **Attention** notices call attention to the possibility of damage to a program, device, system, or data.

World Trade safety information

Several countries require the safety information contained in product publications to be presented in their national languages. If this requirement applies to your country, a safety information booklet is included in the publications package shipped with the product. The booklet contains the safety information in your national language with references to the U.S. English source. Before using a U.S. English publication to install, operate, or service this product, you must first become familiar with the related safety information in the booklet. You should also refer to the booklet any time you do not clearly understand any safety information in the U.S. English publications.

Laser safety information

IBM® System i® models and System p® servers can use I/O cards or features that are fiber-optic based and that utilize lasers or LEDs.

Laser compliance

All lasers are certified in the U.S. to conform to the requirements of DHHS 21 CFR Subchapter J for class 1 laser products. Outside the U.S., they are certified to be in compliance with IEC 60825 as a class 1 laser product. Consult the label on each part for laser certification numbers and approval information.

CAUTION:

This product might contain one or more of the following devices: CD-ROM drive, DVD-ROM drive, DVD-RAM drive, or laser module, which are Class 1 laser products. Note the following information:

- **Do not remove the covers. Removing the covers of the laser product could result in exposure to hazardous laser radiation. There are no serviceable parts inside the device.**
- **Use of the controls or adjustments or performance of procedures other than those specified herein might result in hazardous radiation exposure.**

(C026)

CAUTION:

Data processing environments can contain equipment transmitting on system links with laser modules that operate at greater than Class 1 power levels. For this reason, never look into the end of an optical fiber cable or open receptacle. (C027)

CAUTION:

This product contains a Class 1M laser. Do not view directly with optical instruments. (C028)

CAUTION:

Some laser products contain an embedded Class 3A or Class 3B laser diode. Note the following information: laser radiation when open. Do not stare into the beam, do not view directly with optical instruments, and avoid direct exposure to the beam. (C030)

Power and cabling information for NEBS (Network Equipment-Building System) GR-1089-CORE

The following comments apply to the IBM System i models and IBM System p servers that have been designated as conforming to NEBS (Network Equipment-Building System) GR-1089-CORE:

The equipment is suitable for installation in the following:

- Network telecommunications facilities
- Locations where the NEC (National Electrical Code) applies

The intrabuilding ports of this equipment are suitable for connection to intrabuilding or unexposed wiring or cabling only. The intrabuilding ports of this equipment *must not* be metallically connected to the interfaces that connect to the OSP (outside plant) or its wiring. These interfaces are designed for use as intrabuilding interfaces only (Type 2 or Type 4 ports as described in GR-1089-CORE) and require isolation from the exposed OSP cabling. The addition of primary protectors is not sufficient protection to connect these interfaces metallically to OSP wiring.

Note: All Ethernet cables must be shielded and grounded at both ends.

The ac-powered system does not require the use of an external surge protection device (SPD).

The dc-powered system employs an isolated DC return (DC-I) design. The DC battery return terminal *shall not* be connected to the chassis or frame ground.

Product recycling and disposal

This unit must be recycled or discarded according to applicable local and national regulations. IBM encourages owners of information technology (IT) equipment to responsibly recycle their equipment when it is no longer needed. IBM offers a variety of product return programs and services in several countries to assist equipment owners in recycling their IT products. Information on IBM product recycling offerings can be found on IBM's Internet site at <http://www.ibm.com/ibm/environment/products/prp.shtml>.

Esta unidad debe reciclarse o desecharse de acuerdo con lo establecido en la normativa nacional o local aplicable. IBM recomienda a los propietarios de equipos de tecnología de la información (TI) que reciclen responsablemente sus equipos cuando éstos ya no les sean útiles. IBM dispone de una serie de programas y servicios de devolución de productos en varios países, a fin de ayudar a los propietarios de equipos a reciclar sus productos de TI. Se puede encontrar información sobre las ofertas de reciclado de productos de IBM en el sitio web de IBM <http://www.ibm.com/ibm/environment/products/prp.shtml>.



EU Only

Note: This mark applies only to countries within the European Union (EU) and Norway.

Appliances are labeled in accordance with European Directive 2002/96/EC concerning waste electrical and electronic equipment (WEEE). The Directive determines the framework for the return and recycling of used appliances as applicable throughout the European Union. This label is applied to various products to indicate that the product is not to be thrown away, but rather reclaimed upon end of life per this Directive.

In accordance with the European WEEE Directive, electrical and electronic equipment (EEE) is to be collected separately and to be reused, recycled, or recovered at end of life. Users of EEE with the WEEE marking per Annex IV of the WEEE Directive, as shown above, must not dispose of end of life EEE as unsorted municipal waste, but use the collection framework available to customers for the return, recycling, and recovery of WEEE. Customer participation is important to minimize any potential effects of EEE on the environment and human health due to the potential presence of hazardous substances in EEE. For proper collection and treatment, contact your local IBM representative.

Battery return program

This product may contain sealed lead acid, nickel cadmium, nickel metal hydride, lithium, or lithium ion battery. Consult your user manual or service manual for specific battery information. The battery must be recycled or disposed of properly. Recycling facilities may not be available in your area. For information on disposal of batteries outside the United States, go to <http://www.ibm.com/ibm/environment/products/batteryrecycle.shtml> or contact your local waste disposal facility.

In the United States, IBM has established a return process for reuse, recycling, or proper disposal of used IBM sealed lead acid, nickel cadmium, nickel metal hydride, and other battery packs from IBM Equipment. For information on proper disposal of these batteries, contact IBM at 1-800-426-4333. Please have the IBM part number listed on the battery available prior to your call.

For Taiwan: Please recycle batteries.



For the European Union:



Note: This mark applies only to countries within the European Union (EU).

Batteries or packaging for batteries are labeled in accordance with European Directive 2006/66/EC concerning batteries and accumulators and waste batteries and accumulators. The Directive determines the framework for the return and recycling of used batteries and accumulators as applicable throughout the European Union. This label is applied to various batteries to indicate that the battery is not to be thrown away, but rather reclaimed upon end of life per this Directive.

In accordance with the European Directive 2006/66/EC, batteries and accumulators are labeled to indicate that they are to be collected separately and recycled at end of life. The label on the battery may also include a chemical symbol for the metal concerned in the battery (Pb for lead, Hg for mercury and Cd for cadmium). Users of batteries and accumulators must not dispose of batteries and accumulators as unsorted municipal waste, but use the collection framework available to customers for the return, recycling, and treatment of batteries and accumulators. Customer participation is important to minimize any potential effects of batteries and accumulators on the environment and human health due to the potential presence of hazardous substances. For proper collection and treatment, contact your local IBM representative.

For California: Perchlorate Material - special handling may apply. See www.dtsc.ca.gov/hazardouswaste/perchlorate.

The foregoing notice is provided in accordance with California Code of Regulations Title 22, Division 4.5 Chapter 33. Best Management Practices for Perchlorate Materials. This product/part may include a lithium manganese dioxide battery which contains a perchlorate substance.

IBM Cryptographic Coprocessor Card Return Program

The following information applies only for systems originally sold prior to July 1, 2006:

This machine may contain an optional feature, the cryptographic coprocessor card, which includes a polyurethane material that contains mercury. Please follow local ordinances or regulations for disposal of this card. IBM has established a return program for certain IBM Cryptographic Coprocessor Cards. More information can be found at <http://www.ibm.com/ibm/environment/products/prp.shtml>.

About this topic

This topic provides users with the procedures that describe how to install racks, rack features, and systems or expansion units into a rack.

For information about the accessibility features of this product, for users who have a physical disability, see "Accessibility features," on page 181.

Installing racks, rack features, and systems or expansion units

You might need to install racks, rack features, and systems or expansion units into a rack. This section includes procedures so that you can perform these tasks.

You can perform these tasks or contact a service provider to perform the tasks for you. You might be charged a fee by the service provider for this service.

Rack Safety Notices

You will need to read the rack safety notices before installing equipment. Use the procedure in this section to perform this task.

Before installing a rack, rack features, or a system or expansion unit into a rack, read the following safety information:

DANGER

Observe the following precautions when working on or around your IT rack system:

- Heavy equipment—personal injury or equipment damage might result if mishandled.
- Always lower the leveling pads on the rack cabinet.
- Always install stabilizer brackets on the rack cabinet.
- To avoid hazardous conditions due to uneven mechanical loading, always install the heaviest devices in the bottom of the rack cabinet. Always install servers and optional devices starting from the bottom of the rack cabinet.
- Rack-mounted devices are not to be used as shelves or work spaces. Do not place objects on top of rack-mounted devices.



- Each rack cabinet might have more than one power cord. Be sure to disconnect all power cords in the rack cabinet when directed to disconnect power during servicing.
- Connect all devices installed in a rack cabinet to power devices installed in the same rack cabinet. Do not plug a power cord from a device installed in one rack cabinet into a power device installed in a different rack cabinet.
- An electrical outlet that is not correctly wired could place hazardous voltage on the metal parts of the system or the devices that attach to the system. It is the responsibility of the customer to ensure that the outlet is correctly wired and grounded to prevent an electrical shock.

CAUTION

- Do not install a unit in a rack where the internal rack ambient temperatures will exceed the manufacturer's recommended ambient temperature for all your rack-mounted devices.
- Do not install a unit in a rack where the air flow is compromised. Ensure that air flow is not blocked or reduced on any side, front, or back of a unit used for air flow through the unit.
- Consideration should be given to the connection of the equipment to the supply circuit so that overloading of the circuits does not compromise the supply wiring or overcurrent protection. To provide the correct power connection to a rack, refer to the rating labels located on the equipment in the rack to determine the total power requirement of the supply circuit.
- *(For sliding drawers.)* Do not pull out or install any drawer or feature if the rack stabilizer brackets are not attached to the rack. Do not pull out more than one drawer at a time. The rack might become unstable if you pull out more than one drawer at a time.
- *(For fixed drawers.)* This drawer is a fixed drawer and must not be moved for servicing unless specified by the manufacturer. Attempting to move the drawer partially or completely out of the rack might cause the rack to become unstable or cause the drawer to fall out of the rack.

(R001)

If you are installing equipment into a non-IBM rack, the rack must comply with the Electronics Industries Association (EIA) 310D specifications. If you do not have a rail kit designed for the equipment in the non-IBM rack, do not install the equipment into the rack as damage to the equipment or personal injury could occur.

Lift precautions:

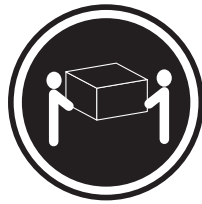

≥ 18 kg (39.7 lb)



≥ 32 kg (70.5 lb)

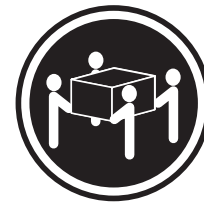

≥ 55 kg (121.2 lb)

IPHBF442-0

Completing a parts inventory

You might need to complete a parts inventory. Use the procedure in this section to perform this task.

If you have not done so, complete a parts inventory before proceeding with the installation:

1. Locate the kitting report in an accessory box.
2. Ensure that you received all the parts that were ordered.

If there are incorrect, missing or damaged parts, contact:

- Your IBM reseller
- IBM Rochester Manufacturing Automated Information Line at 1-800-300-8751 (United States only)
- <http://www.ibm.com/planetwide>: Locate your service and support telephone numbers

Installing the rack

You might need to install the rack. Use the procedure in this section to perform this task.

The following procedures describe how to install a rack.

If you are installing a system unit into an existing rack, see *Install the system unit or expansion unit into a rack*.

Installing the 7014-T00, 7014-T42, 0551, or 0553 racks

You might need to install the rack. Use the procedure in this section to perform this task.

If you are installing a rack security kit in this rack, see “Installing the rack security kit” on page 56 after you have installed the rack.

Before installing a rack, read the “Rack Safety Notices” on page 1.

Completing a parts inventory

You might need to complete a parts inventory. Use the procedure in this section to perform this task.

If you have not done so, complete a parts inventory before installing the system unit in the rack:

1. Locate the kitting report in an accessory box.
2. Ensure that you received all of the features that you ordered and all of the parts on the kitting report.

If there are incorrect, missing, or damaged parts, contact:

- Your IBM reseller
- IBM Rochester Manufacturing Automated Information Line at 1-800-300-8751 (United States only)
- Directory of worldwide contacts Web site at <http://www.ibm.com/planetwide> .

Positioning the rack

You might need to position the rack. Use the procedure in this section to perform this task.

The -48 V dc rack must be installed only in restricted access areas, such as dedicated equipment rooms or equipment closets, in accordance with Articles 110-16, 110-17, and 110-18 of the National Electrical Code, ANSI/NFPA No. 70.

After the rack has been placed into its location on the floor, lock each caster by tightening the locking screw. See the following illustration for the locking screw location. Remove all of the tape and packing materials from the rack.

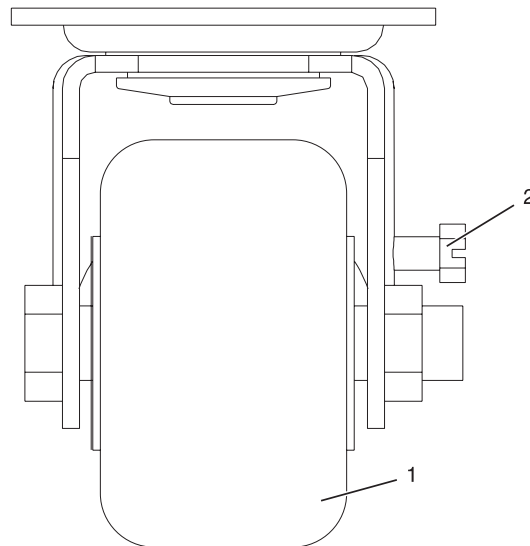

- 1 Caster
2 Locking screw

Figure 1. Tightening the locking screw.

Use the following to determine the next step:

- If the rack is being bolted to a concrete floor, go to “Attaching the rack to a concrete floor” on page 6.
- If the rack is being bolted to a concrete floor beneath a raised floor, go to “Attaching the rack to the concrete floor beneath a raised floor” on page 11.
- If the rack is not being attached to the floor, go to “Leveling the rack.”

Leveling the rack

You might need to level the rack. Use the procedure in this section to perform this task.

To level the rack, complete the following steps:

1. Loosen the jam nut on each leveling foot.
2. Rotate each leveling foot downward until it contacts the surface on which the rack is placed.

3. Adjust the leveling feet downward as needed until the rack is level. When the rack is level, tighten the jam nuts against the base.

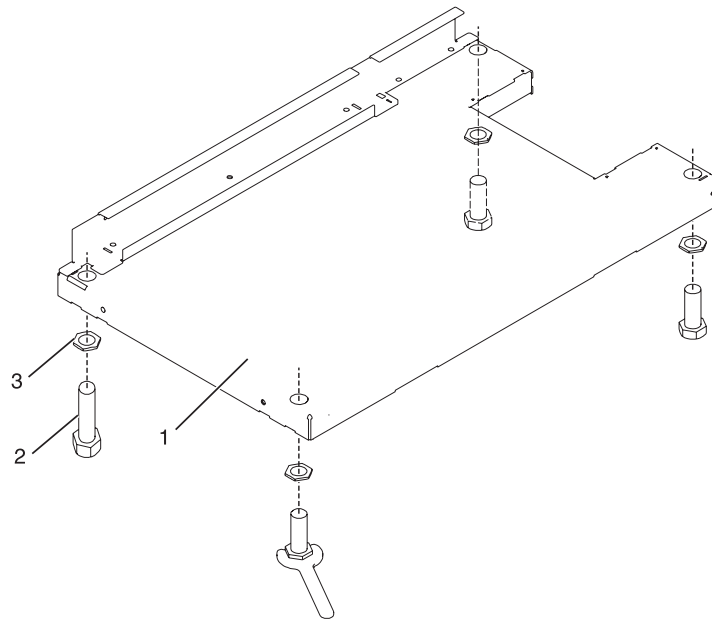

- 1 Rack Front (base)
- 2 Leveling Foot (quantity 4)
- 3 Jam Nut (quantity 4)

Figure 2. Adjusting the leveling feet.

Attaching the stabilizer brackets

You might need to attach the stabilizer brackets to the rack. Use the procedure in this section to perform this task.

If the front or back ac electrical outlets are going to be installed in the rack, you cannot attach the stabilizer brackets. The rack must be bolted to the floor.

Stabilizer brackets are used only if you will not be bolting the rack to the floor. If you are going to bolt the rack to the floor, go to “Attaching the rack to a concrete floor” on page 6.

To attach the stabilizer brackets to the bottom of the rack, do the following:

Note: Before installing the stabilizer brackets, refer to “Attaching the front or back ac electrical outlet” on page 16 for instruction on installing the ac outlet-mounting plates.

1. Align the slots of one of the stabilizer brackets with the mounting holes at the bottom front of the rack.
2. Install the two mounting screws.
3. Ensure that the base of the stabilizer bracket rests firmly on the floor. Use the Allen wrench that was supplied with the rack to tighten the mounting screws alternately until they are tight.

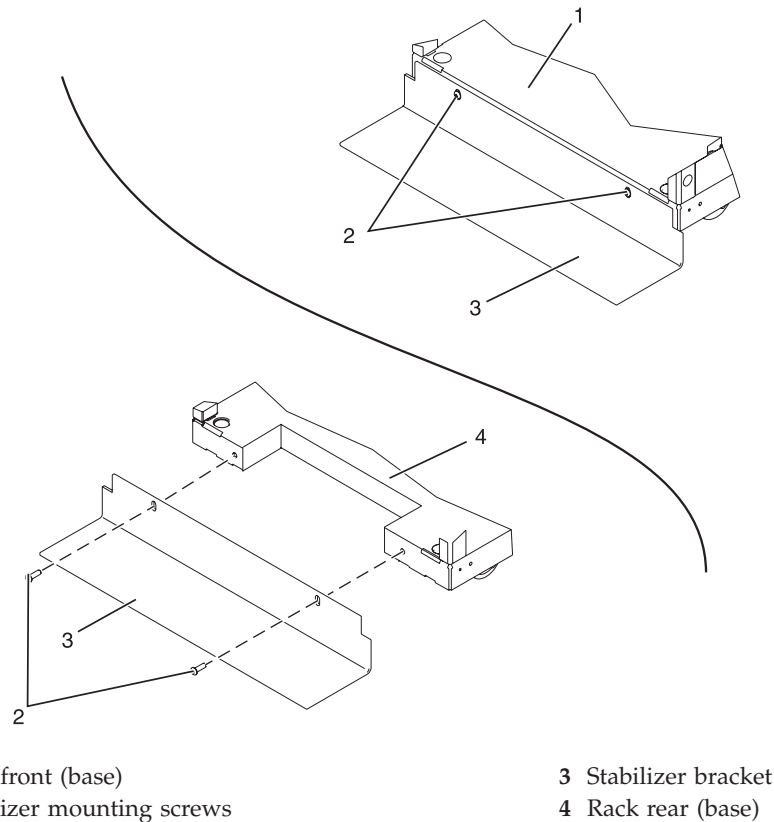

Figure 3. Attaching the stabilizer brackets.

4. To install the second stabilizer bracket on the back of the rack, repeat steps 1 through 3.

Attaching the rack to a concrete floor

You might need to attach the rack to a concrete floor. Use the procedure in this section to perform this task.

Obtain the services of a mechanical contractor to attach the rack-mounting plates to the concrete floor. The mechanical contractor needs to determine that the hardware being used to secure the rack-mounting plates to the concrete floor is sufficient to meet the requirements for the installation.

To attach the rack to a concrete floor, do the following:

1. Put the rack in its predetermined location, and tighten the locking screws on the casters.
2. If installed, remove the top, left, and right trim panels. The trim panels are held in place with spring clips. See the following illustration.

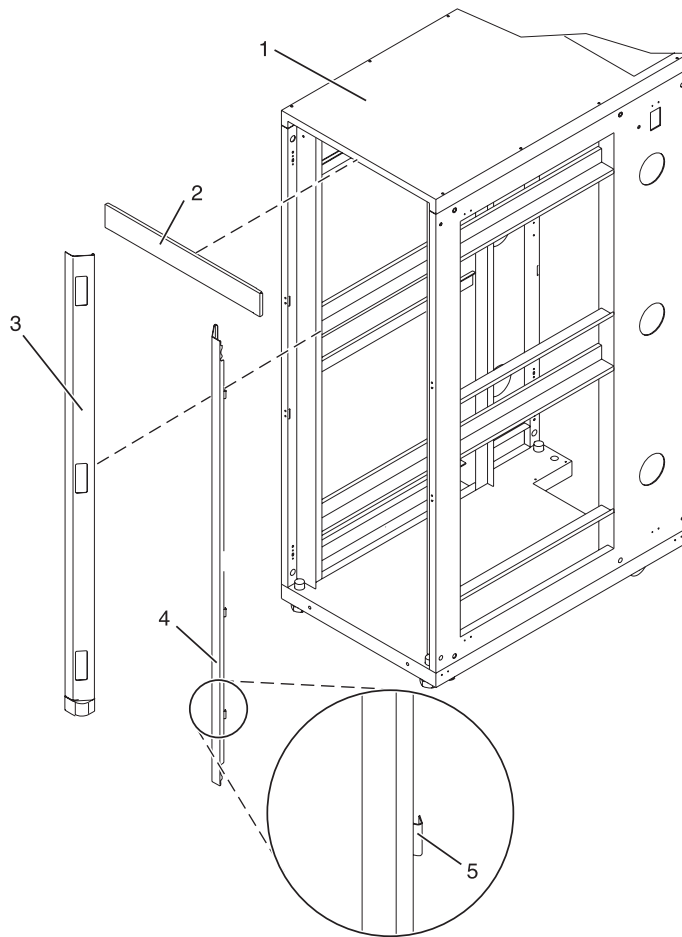

- 1 Rack chassis
- 2 Top trim panel
- 3 Left-side trim panel

- 4 Right-side trim panel
- 5 Spring clip

Figure 4. Removing the trim panels.

3. If installed, remove the front and back doors. To remove a rack door, go to “Attaching the rack doors” on page 29. After the rack doors have been removed, go to the next substep.
4. Locate the hardware mounting kit and the two mounting plates. Refer to the following illustration when reviewing the contents of the hardware mounting kit. The hardware mounting kit contains the following:
 - 4 Rack-mounting bolts
 - 4 Thin washers
 - 8 Plastic isolator bushings
 - 4 Thick washers
 - 4 Spacers
5. If you are installing a dc-powered rack, insert each bushing into a leveling foot as shown in the following illustration. On a dc-powered rack, *do not* remove the lower plastic isolator bushings from the leveling feet.

Note: If you are installing an ac-powered rack, temporarily install the lower plastic isolator bushings to help you locate the mounting locations for the stabilizer bracket. After the stabilizer bracket has

been correctly located, remove the lower plastic isolator bushings.

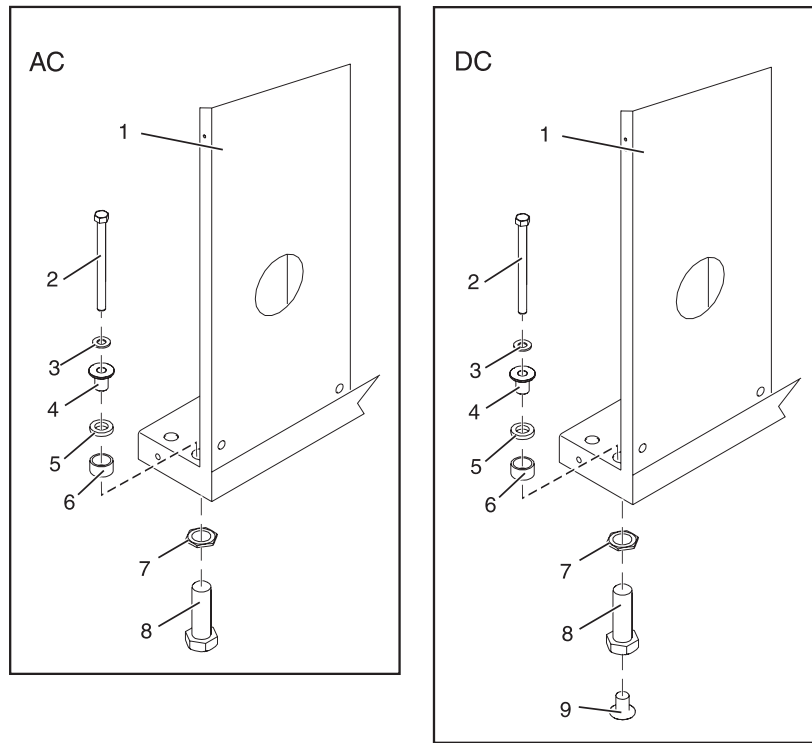
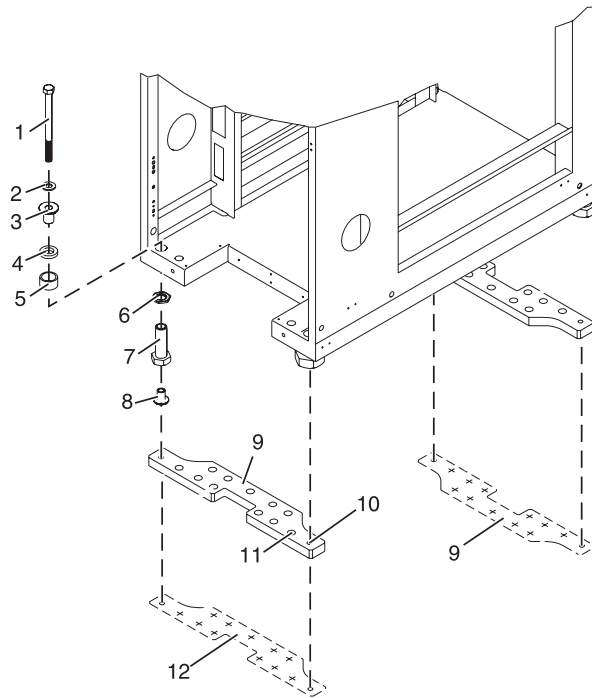

Figure 5. Installing ac-power and dc-power mounting plates

- 1 Rack chassis
- 2 Rack-mounting bolt
- 3 Thin washer
- 4 Top plastic isolator bushing
- 5 Thick washer
- 6 Spacer

- 7 Jam nut
- 8 Leveling foot
- 9 Lower plastic isolator bushing (used only on dc powered systems)
- AC Typical leveling foot installation for an ac-powered rack
- DC Typical leveling foot installation for a dc-powered rack

6. Position the two mounting plates in the approximate mounting location under the rack.
7. Create a rack-mounting bolt assembly by adding the following items, in the order listed, to each rack-mounting bolt.
 - a. Thin flat washer
 - b. Top plastic isolator bushing
 - c. Thick flat washer
 - d. Spacer
8. Insert a rack-mounting bolt assembly through each of the leveling feet.
9. Reposition the rack-mounting plates under the four rack-mounting bolts so that the mounting bolts are centered directly over the threaded bolt holes.
10. Turn the rack-mounting bolts four complete turns into the mounting plate's threaded bolt holes.



- | | |
|--------------------------------|--|
| 1 Rack-mounting bolt | 7 Leveling foot |
| 2 Thin washer | 8 Lower plastic isolator bushing (Used only on dc powered systems) |
| 3 Top plastic isolator bushing | 9 Mounting plate |
| 4 Thick washer | 10 Threaded hole (Used to secure the rack to stabilizer bracket.) |
| 5 Spacer | 11 Anchor bolt hole |
| 6 Jam nut | 12 Traced pattern (Pattern to be traced onto the floor using the stabilizer bracket as a template) |

Figure 6. Securing the rack to the floor.

11. Mark the floor around the edges of both stabilizer brackets.
12. Mark the plate bolt-down holes that are accessible through the opening in the rear of the rack.
13. Remove the rack-mounting bolt assemblies.
14. If you are installing an ac-powered rack, remove the bottom isolator bushing from each of the leveling feet. If you are installing a dc-powered rack, the bottom isolator bushings *must* remain installed in each of the leveling feet.
15. Remove the stabilizer brackets from the marked locations.
16. Loosen each of the locking screws on the casters.
17. Move the rack so that it is clear of both areas that were marked on the floor for the stabilizer brackets locations.
18. Reposition the stabilizer brackets within the marked areas.
19. Mark the floor at the center of all holes in both stabilizer brackets.
20. Remove the two rack-mounting plates from the marked areas.

- At the marked location of the threaded rack-mounting bolt holes, drill four clearance holes into the concrete floor. Each clearance hole should be approximately 1-inch deep. This allows the rack-mounting bolts enough room to protrude past the thickness of the stabilizer brackets.

Note: You *must* use a minimum of two anchor bolts for each rack-mounting plate to securely attach the plate to the concrete floor. Because some of the holes in each rack-mounting plate may align with concrete reinforcement rods embedded in the concrete, some of the rack-mounting plate holes may not be usable.

- Select at least two suitable hole locations for each stabilizer bracket bolt. The selected locations should be as close to the threaded bolt holes as possible. Be sure that the holes selected at the back of the rack are accessible. Drill holes at the selected locations into the concrete floor.
- Position the stabilizer brackets over the concrete anchors.
- Securely bolt the front stabilizer bracket to the concrete floor.
- Position the stabilizer bracket over the concrete anchors.
- Securely bolt the back stabilizer bracket to the concrete floor.

Note: The size of the anchor bolts and concrete anchors *must* be determined by the mechanical contractor doing the rack-mounting plate installation.

- Position the rack over the stabilizer bracket.
- Insert each of the stabilizer bracket bolts through a flat washer, a plastic isolator bushing and a thick washer, and through a leveling foot.
- Align the four stabilizer brackets bolts with the four tapped holes in the two mounting plates and turn three to four rotations.
- Tighten the locking screw on each caster.
- Adjust the leveling feet downward as needed until the rack is level. When the rack is level, tighten the jam nuts against the base of the rack.

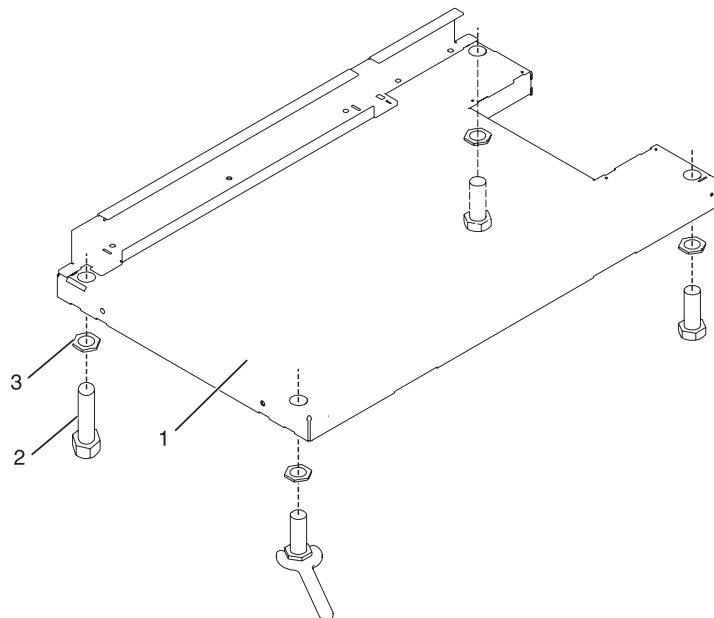

- Rack front (base)
- Leveling foot (quantity 4)
- Jam nut (quantity 4)

Figure 7. Adjusting the leveling feet.

32. If you have multiple racks that are connected in a suite (bolted to each other), go to “Connecting multiple racks with rack-to-rack attachment kit” on page 62. Otherwise, torque the four bolts to 40-50 ft-lbs (54-67 nm).
33. If you are not installing doors on your rack, install the top, left, and right trim panel.
34. Connect the power distribution system as described in “Connecting the power distribution system” on page 15.
35. After all racks are bolted down, go to “Attaching the front or back ac electrical outlet” on page 16.
36. If you are not going to attach a front electrical outlet and you are installing rack doors, go to “Attaching the rack doors” on page 29

Attaching the rack to the concrete floor beneath a raised floor

You might need to attach the rack to the floor. Use the procedure in this section to perform this task.

Obtain the services of a mechanical contractor to attach the rack-mounting plates to the concrete floor. The mechanical contractor needs to determine that the hardware being used to secure the rack-mounting plates to the concrete floor is sufficient to meet the requirements for the installation.

To attach the rack to a concrete floor beneath a raised floor, do the following:

1. Put your rack in its predetermined location and tighten the locking screws on the casters.
2. If installed, remove the top, left and right trim panels. The trim panels are held in place with spring clips. See the following illustration.

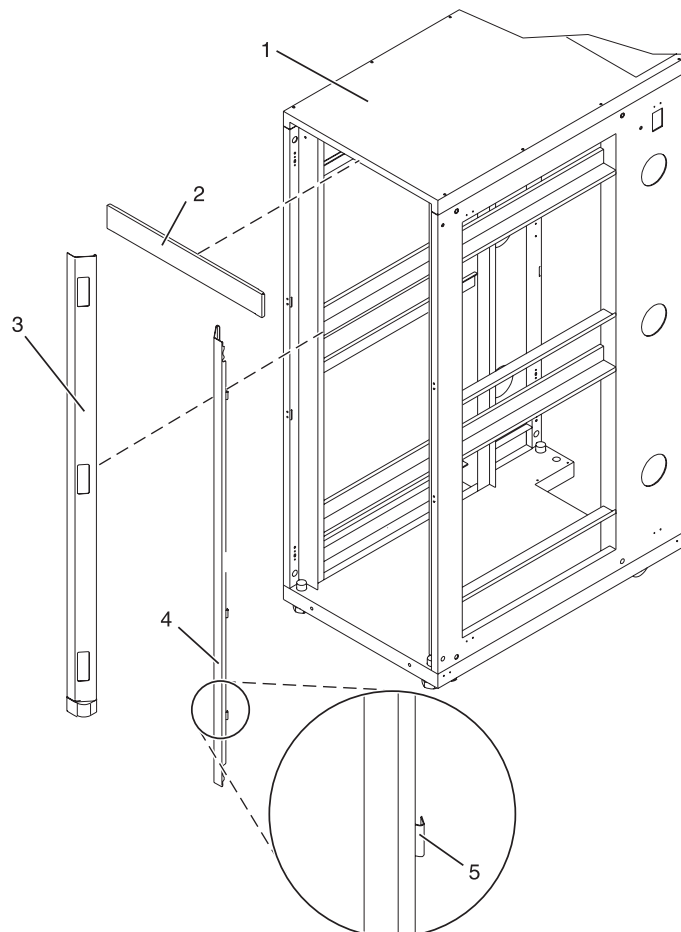

- | | |
|------------------------|-------------------------|
| 1 Rack chassis | 4 Right-side trim panel |
| 2 Top trim panel | 5 Spring clip |
| 3 Left-side trim panel | |

Figure 8. Removing the trim panels.

3. If installed, remove the front and rear doors. To remove a rack door, go to “Attaching the rack doors” on page 29. After the rack doors have been removed, go to the next substep.
4. Locate the hardware mounting kit and the two mounting plates. Refer to the following illustration when reviewing the contents of the hardware mounting kit. The hardware mounting kit contains the following:
 - Four rack-mounting bolts
 - Four thin washers
 - Eight plastic isolator bushings
 - Four thick washers
 - Four spacers
5. If you are installing a dc-powered rack, insert each bushing into a leveling foot as shown in the following illustration. On a dc-powered rack, *do not* remove the lower plastic isolator bushings from the leveling feet.

Note: If you are installing an ac-powered rack, temporarily install the lower plastic isolator bushings to help you locate the rack-mounting plate. After the mounting plate has been correctly located, remove the lower plastic isolator bushings.

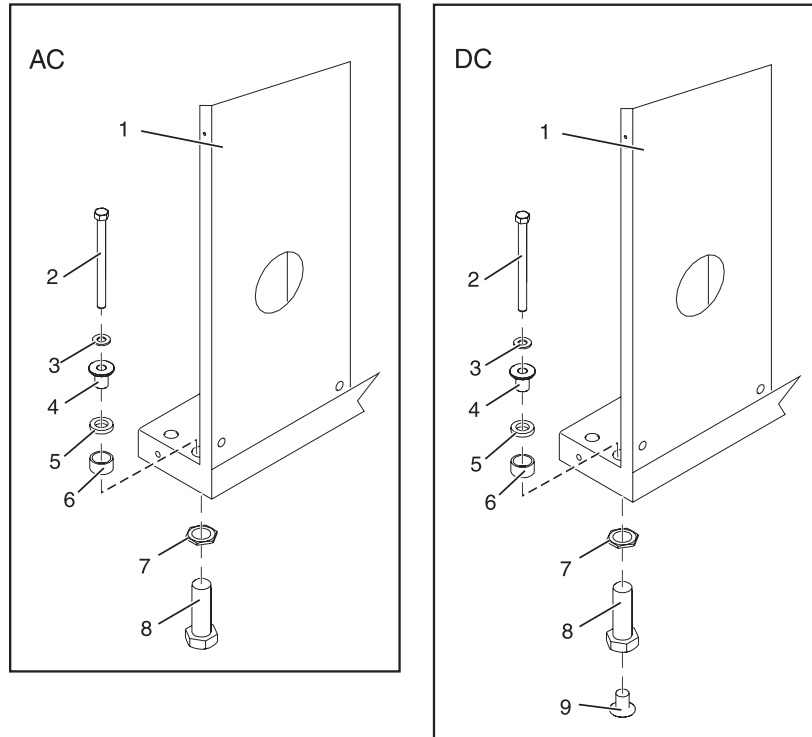

Figure 9. Installing the ac and dc power-mounting plates.

- | | |
|----------------------|-----------------|
| 1 Rack chassis | 7 Jam nut |
| 2 Rack-mounting bolt | 8 Leveling foot |

- | | |
|--------------------------------|--|
| 3 Thin washer | 9 Lower plastic isolator bushing (used only on dc powered systems) |
| 4 Top plastic isolator bushing | AC Typical leveling foot installation for an ac-powered rack |
| 5 Thick washer | DC Typical leveling foot installation for an dc-powered rack |
| 6 Spacer | |

6. Position the two mounting plates in the approximate mounting location under the rack.
7. Create a rack-mounting bolt assembly by adding the following items, in the order listed, to each rack-mounting bolt.
 - a. Thin flat washer
 - b. Top plastic isolator bushing
 - c. Thick flat washer
 - d. Spacer
8. Insert a rack-mounting bolt assembly through each of the leveling feet.
9. Reposition the rack-mounting plates under the four rack-mounting bolts so that the mounting bolts are centered directly over the threaded bolt holes.
10. Turn the rack-mounting bolts four complete turns into the mounting plate's threaded bolt holes.
11. Mark the raised-floor panel around the edges of front and back rack-mounting plates.
12. Mark the plate bolt-down holes that are accessible through the opening in the back of the rack.
13. Remove the rack-mounting bolt assemblies.
14. If you are installing an ac-powered rack, remove the bottom isolator bushing from each of the leveling feet. If you are installing a dc-powered rack, the bottom isolator bushings *must* remain installed in each of the leveling feet.
15. Remove the rack-mounting plates from the marked locations.
16. Loosen each of the locking screws on the casters.
17. Move the rack so that it is clear of both areas that were marked on the floor for the rack-mounting plate locations.
18. Reposition the mounting plates within the marked areas.
19. Mark the raised-floor panel at the center of each hole in the rack-mounting plates (including the tapped holes).
20. Remove the two rack-mounting plates from the marked locations on the raised floor panel.
21. Drill two clearance holes on each end of each rack-mounting plate. The drilled holes should be approximately 1-inch deep. This will accommodate any rack-mounting bolt extending past the rack-mounting plate when securing the rack to the rack-mounting plate.
22. For each rack-mounting plate, select at least two suitable hole locations. Select the hole locations as close to the threaded hole areas as possible. Be sure the hole locations selected at the back of the rack are accessible.
23. Drill pass-through holes in the raised-floor panel. The pass-through holes allow the anchor bolts to be inserted into the rack-mounting plate and pass through the raised floor panel to the concrete floor.

Note: You *must* use a minimum of two anchor bolts for each rack-mounting plate to securely attach the rack-mounting plate through the raised-floor panel to the concrete floor. Because some of the holes in each rack-mounting plate may align with concrete reinforcement rods imbedded in the concrete, some of the rack-mounting plate holes may not be usable.

24. Transfer the locations of the anchor bolt holes (exclude the clearance holes drilled for the rack-mounting bolts) from the raised-floor panel to the concrete floor directly beneath, and mark the hole locations on the concrete floor.

25. Drill holes in the concrete floor to secure the anchor bolts.
26. Position the raised-floor panel back into position over the anchor bolt holes.
27. Position the front stabilizer bracket within the marked area on the raised-floor panel.
28. Using your anchor bolts, secure the front stabilizer brackets on top of the raised floor and through to the concrete floor.
29. Position the rear stabilizer brackets within the marked area on the raised-floor panel.

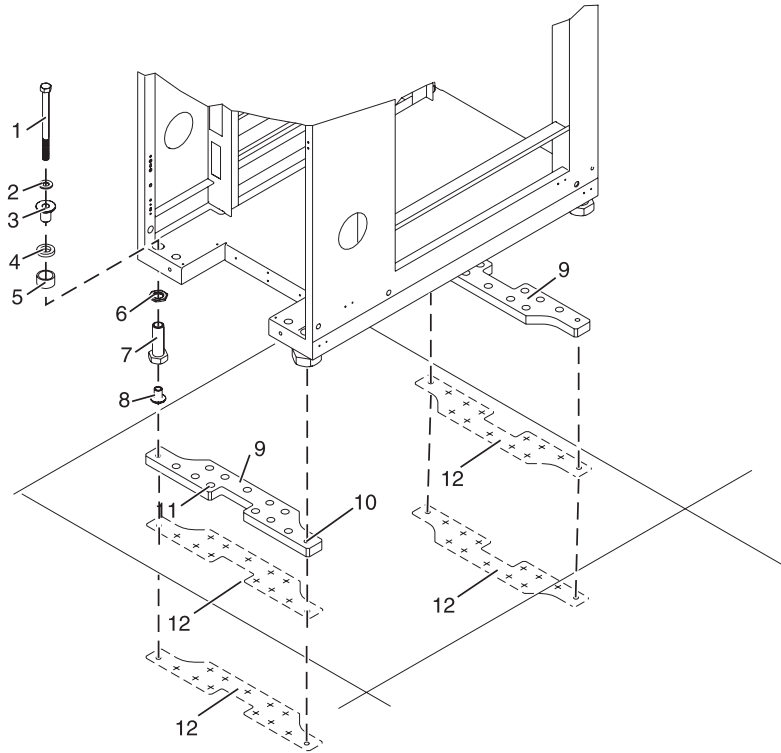

- | | |
|--------------------------------|--|
| 1 Rack-mounting bolt | 7 Leveling foot |
| 2 Thin washer | 8 Lower plastic isolator bushing (used only on dc-powered systems) |
| 3 Top plastic isolator bushing | 9 Stabilizer brackets |
| 4 Thick washer | 10 Threaded hole (used to secure the rack to mounting plate.) |
| 5 Spacer | 11 Anchor bolt hole |
| 6 Jam nut | 12 Traced pattern (pattern to be traced onto the floor using the mounting plate as a template) |

Figure 10. Securing the rack to the floor.

30. Using your anchor bolts, secure the back stabilizer bracket on top of the raised floor and through to the concrete floor.
 31. Replace all raised-floor panels that may have been removed when aligning and securing the anchor bolts to the concrete floor.
 32. Align the rack over the front and back stabilizer brackets.
 33. Insert each of the bolt assemblies through a leveling foot.
 34. Align the rack-mounting bolts with the threaded holes in each stabilizer bracket. Turn each bolt three to four rotations.
 35. Tighten the locking screw on each caster.
- 14** System i and System p: Installing the rack, rack features, and system or expansion unit into a rack

36. Adjust the leveling feet downward as needed until the rack is level. When the rack is level, tighten the jam nuts against the base of the rack.
37. If you have multiple racks that are connected as a suite (bolted to each other), go to “Connecting multiple racks with rack-to-rack attachment kit” on page 62. Otherwise, torque the four bolts to 40-50 ft-lbs (54-67 nm).
38. If you are not installing doors on your rack, install the top, left, and right trim panel.
39. Connect the power distribution system as described in “Connecting the power distribution system.”
40. After the rack is bolted down and you are going to attach a front electrical outlet, go to “Attaching the front or back ac electrical outlet” on page 16.
41. If you are not going to attach a front electrical outlet and you are installing rack doors, go to “Attaching the rack doors” on page 29.

Connecting the power distribution system

You might need to connect a power distribution system. Use the procedure in this section to perform this task.

Select from the following items:

- “Checking the ac outlets”
- “Connecting a dc power source” on page 19

Checking the ac outlets

You might need to check the ac outlets. Use the procedure in this section to perform this task.

Before plugging the rack into the ac power source, complete the following checks on the ac power source.

1. Turn off the branch circuit breaker for the ac power outlet that the rack will plug into. To the circuit breaker switch, attach tag S229-0237, which reads “Do Not Operate.”

Note: All measurements are made with the receptacle faceplate in the usual installed position.

2. Some receptacles are enclosed in metal housings. For this type of receptacle, do the following:
 - a. Check for less than 1 volt from the receptacle case to any grounded metal structure in the building, such as a raised-floor metal structure, water pipe, building steel, or similar structure.
 - b. Check for less than 1 volt from the receptacle ground pin to a grounded point in the building.

Note: If the receptacle case or faceplate is painted, be sure the probe tip penetrates the paint and makes good electrical contact with the metal.

- c. Check the resistance from the receptacle ground pin to the receptacle case. Check resistance from the ground pin to the building ground. The readings should be less than 1.0 ohm, which indicates the presence of a continuous grounding conductor.
3. If any of the three checks made in substep 2 are not correct, ask the customer to remove the power from the branch circuit and make the wiring corrections; then check the receptacle again.

Note: Do not use a digital multimeter to measure grounding resistance in the following steps.

4. Check for infinite resistance between the ground pin of the receptacle and each of the phase pins. This is a check for a wiring short to ground or a wiring reversal.
5. Check for infinite resistance between the phase pins. This is a check for a wiring short.
6. Turn on the branch circuit breaker. Measure for the appropriate voltages between phases. If no voltage is present on the receptacle case or grounded pin, the receptacle is safe to touch.
7. With an appropriate meter, verify that the voltage at the ac outlet is correct.
8. Verify that the grounding impedance is correct by using the ECOS 1020, 1023, B7106, C7106, or an appropriately approved ground-impedance tester.

Attaching the front or back ac electrical outlet

You might need to attach an ac outlet. Use the procedure in this section to perform this task.

Attention: The front and back ac outlet-mounting plates mount through the same mounting holes in that secure the stabilizer brackets to the rack chassis. Therefore, if the rack must be bolted to the floor, the stabilizer brackets must be removed.

Install the ac outlet-mounting plates only after the rack has been bolted to the floor and the stabilizer brackets have been removed.

The following items are installed at the customer's site:

- The ac outlet-mounting plates for installing customer-supplied ac electrical outlets on the front or back of the rack. The ac outlet-mounting place provides the mounting location for an ac electrical outlet.
- The brass ground lug for an electrostatic discharge (ESD) connection.

Note: The customer is responsible for providing both the outlets and the power cables that attach to the power source. The customer is also responsible for connecting the ac outlet correctly. These items are not field-replaceable units (FRUs).

Installing the ac outlet-mounting plates with ac outlets:

You might need to install ac mounting plates. Use the procedure in this section to perform this task.

If you do not want ac outlets installed on the rack, go to "Installing the ac outlet-mounting plate without ac outlets" on page 18.

If you want ac outlets installed on the front or back ac outlet-mounting plate, do the following:

1. Determine the number of ac outlets that you are installing.
2. Confirm with your contractor that the number and location of ac outlets to be installed are correct.
3. Remove the blank filler plates from the ac outlet-mounting plates for the number of ac outlets being installed.
4. Install the ac outlets on the ac outlet-mounting plate.
5. Install the ground lug in the ac outlet-mounting plate using only one nut, as shown in the following illustration.
6. Securely tighten the one nut on the ground lug.
7. Locate the "Y"-shaped ground cable supplied with the mounting plate.

Note: The following steps can be used to install ac outlets on the front or the back of the rack.

8. Place the star washer onto the ground lug of the front ac outlet-mounting plate.
9. Place the lug on the long end of the ground cable onto the ground lug.
10. Place a ground lug nut onto the ground lug and securely tighten it.
11. Position the front ac outlet-mounting plate onto the rack frame with the ground lug fully inserted through the mounting holes in the rack.
12. Route the cable under the rack.
13. Place the star washer onto the ground lug of the back ac outlet-mounting plate.
14. Place the lug on the short end of the ground cable onto the ground lug.
15. Place a ground lug nut onto the ground lug and securely tighten it.

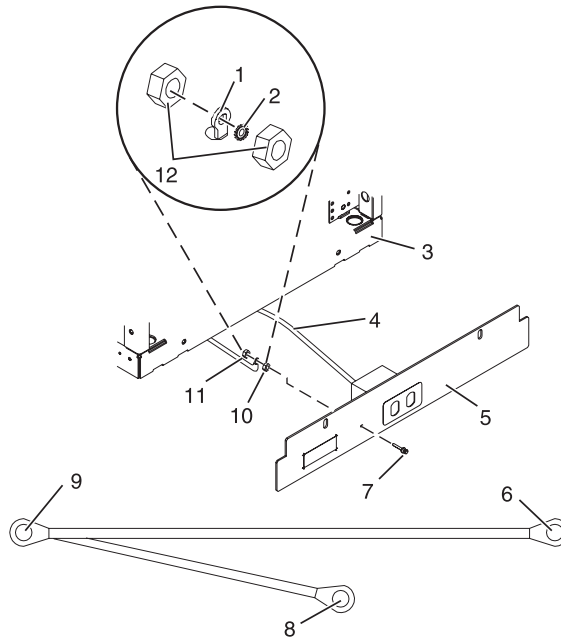

- | | |
|-------------------------------------|--|
| 1 Ground cable lug | 7 Ground lug |
| 2 Star washer | 8 Ground connector (short end of ground cable) |
| 3 Front of rack | 9 "Y" End of ground cable |
| 4 Power cable from the power source | 10 Ground lug nut (quantity 2) |
| 5 Mounting plate | 11 Long end of ground cable |
| 6 Long end of ground cable | 12 Ground lug nut (quantity 2) |

Figure 11. Installing the ground lug.

16. Position the back ac outlet-mounting plate onto the rack frame with the ground lug fully inserted through the mounting holes in the rack.
17. Install the front ac outlet-mounting plate screws (stabilizer mounting screws) into the mounting plate and through the mounting holes in the rack. Securely tighten the screws.

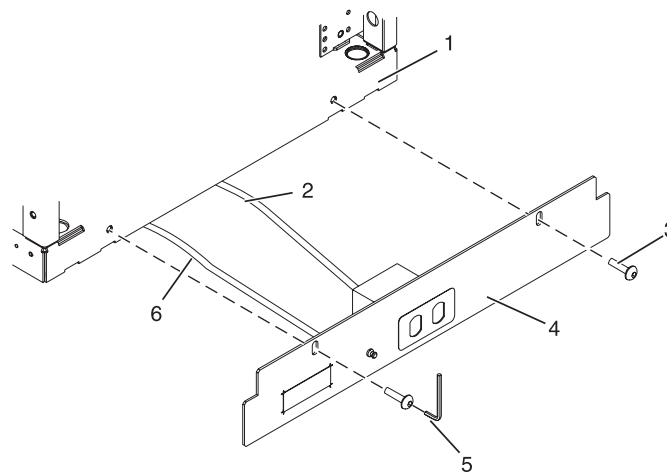

- | | |
|---|------------------|
| 1 Front or back of rack (as applicable) | 4 Mounting plate |
| 2 Power cable from power source | 5 Allen wrench |

3 Button-head screw

6 Long end of ground cable

Figure 12. Installing the front mounting plate.

18. Connect the "Y"-shaped end of the ground cable to the rack frame, either near the center in the back of the rack or to the ground bus bar at the back of the rack.
19. Install the back ac outlet-mounting plate screws (stabilizer mounting screws) into the mounting plate and through the mounting holes in the rack. Securely tighten the screws.

Note: The bus bar might be located at either the top or bottom of the rack.

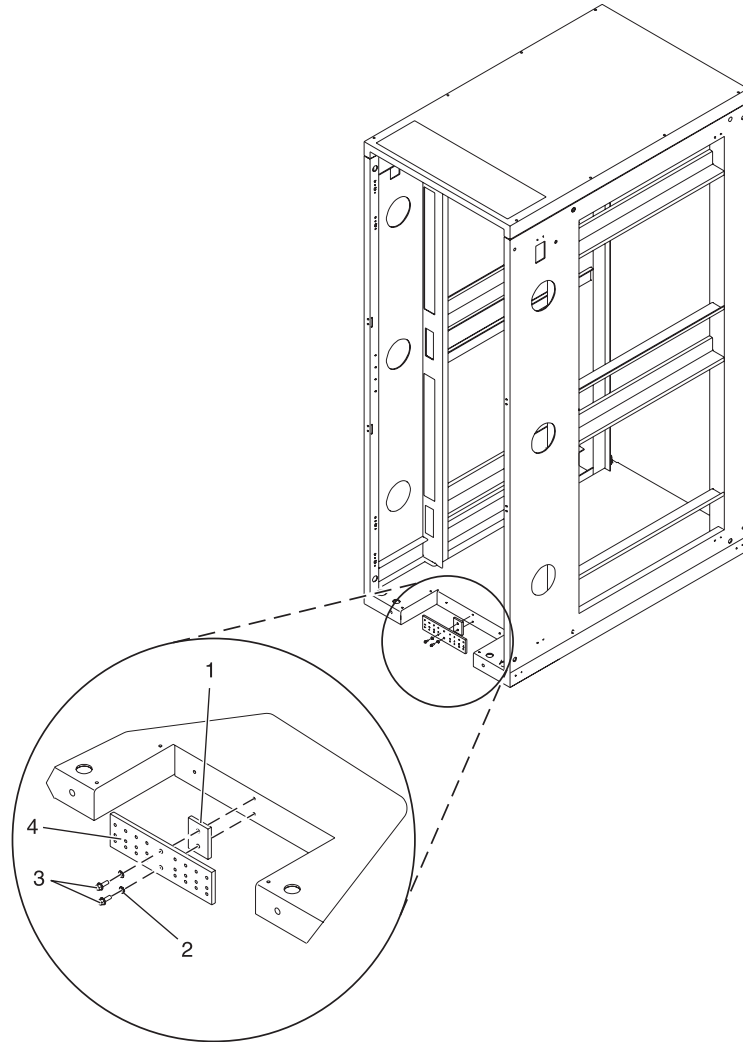

1 Bus bar mounting plate
2 Lock washer (quantity 2)

3 Hex screws (M5 x 20) (quantity 2)
4 Ground bus bar

Figure 13. Installing the back mounting plate.

Installing the ac outlet-mounting plate without ac outlets:

You might need to install an outlet plate without the outlets. Use the procedure in this section to perform this task.

- 18 System i and System p: Installing the rack, rack features, and system or expansion unit into a rack

If you do not want any ac outlets installed on the front or rear ac outlet-mounting plate, perform only “Attaching the rack to the concrete floor beneath a raised floor” on page 11 through “Connecting the power distribution system” on page 15.

For front or rear ac outlet-mounting plates, refer to “Installing the ac outlet-mounting plates with ac outlets” on page 16.

Connecting a dc power source

You might need to connect a dc power source to the rack. Use the procedure in this section to perform this task.

Note: The customer is responsible for providing and connecting the -48 V dc power source and -48 V dc power return cables from the customer’s source -48 V dc to the bus bars in the power distribution panel. The customer is also responsible for connecting the ground cable to the rack frame. This procedure provides information about accessing the power distribution panel.

1. Remove the six mounting screws from the top cover of the dc power distribution panel and remove the top cover.
2. If installed, remove the four screws from the cable channel cover.
3. Remove the cable channel cover.

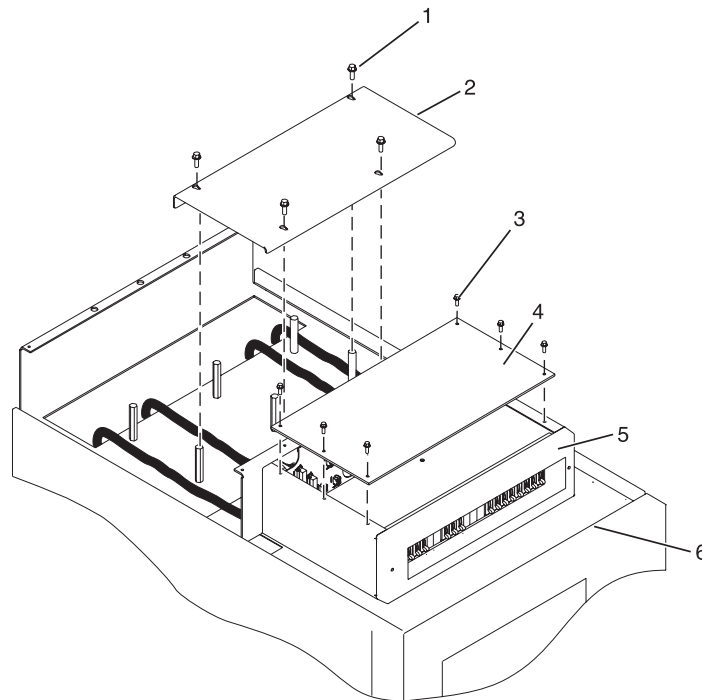

- | | |
|---|----------------------------|
| 1 Cable channel cover retaining screw | 5 Shield |
| 2 Cable channel cover | 6 Power distribution panel |
| 3 Power distribution panel top cover retaining screws | 7 Front of rack |
| 4 Power distribution panel top cover | |

Figure 14. Removing the cable channel cover.

4. Remove the -48 V dc bus bar shield from the power distribution panel.

Attention: The bus bar shield must be correctly reinstalled over the -48 V dc return bus bars to protect against injury while servicing the power distribution panel.

5. Ensure that the following steps are performed when connecting the dc power source.
 - a. At -48 V dc power source, turn off any -48 V dc power sources that will be connected to the power distribution panel.
 - b. After the -48 V dc power sources are turned off, be sure there is a tag or label over the power source switches or fuses (lock-out/tag-out) to indicate that the power source is turned off intentionally.

Note: Ensure that any oxidation on the copper bus bars is removed.

- c. If this is a raised-floor installation and you are working at the back of the rack, route the power cables up the rack's right side.
- d. Ensure that the external -48 V dc power cable is connected correctly to the -48 V dc bus bar.
- e. Ensure that the external -48 V dc return cable is routed correctly and installed on the return bus bar.

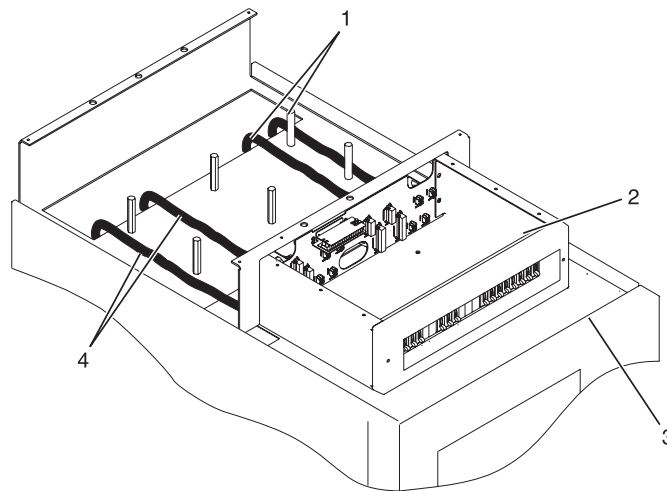

- 1 -48 V dc power cable and return power cable
- 2 Power distribution panel
- 3 Front of rack
- 4 -48 V dc power cable and return power cable

Figure 15. Routing the power cables.

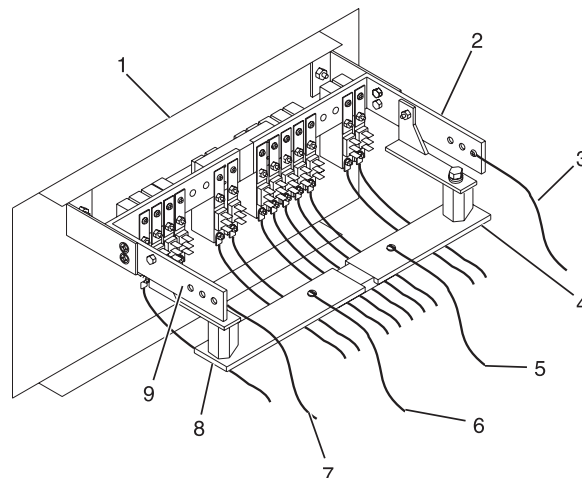

- | | |
|-------------------------------------|--------------------------------|
| 1 Front of power distribution panel | 6 (B) Return (-) power cable |
| 2 (A) -48 V dc (-) bus bar | 7 (B) -48 V dc (-) power cable |
| 3 (A) -48 V dc (-) power cable | 8 (B) Return (-) bus bar |
| 4 (A) Return (-) bus bar | 9 (B) -48 V dc (-) bus bar |
| 5 (A) Return (-) power cable | |

Figure 16. Return bus bar.

- f. If you want to install a power status alarm, connect the alarm cable to the terminal board on the back cover of the dc power distribution panel.

Note: Ensure that the oxidation on the copper bus bars is removed.

- g. Ensure that the power-source ground cable is routed correctly and connects the power-source ground cable to the copper bar at the lower-back or upper-back center of the rack.
- h. If the rack is on a raised floor, attach the -48 V dc power source cables to the back of the rack with cable-restraint straps.

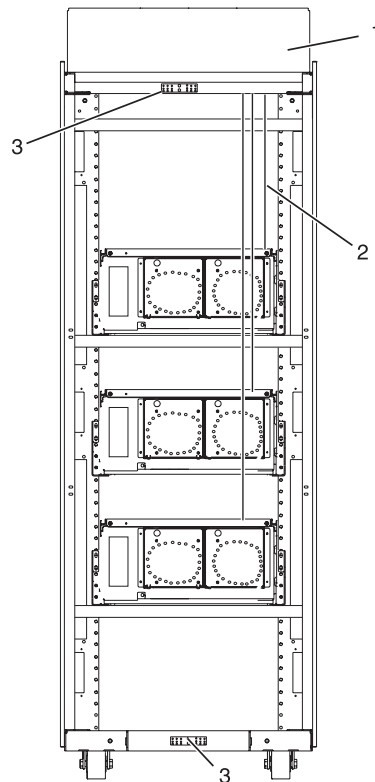

- 1 Back view of rack (dc)
 2 Power cable, power return cable, and ground
 3 Ground cable (Install at either top or bottom of the rack)

Figure 17. Cable locations.

6. Reinstall the -48 V dc bus bar shield.
7. Reinstall the top cover on the dc power distribution panel.
8. Reinstall the cable channel cover.

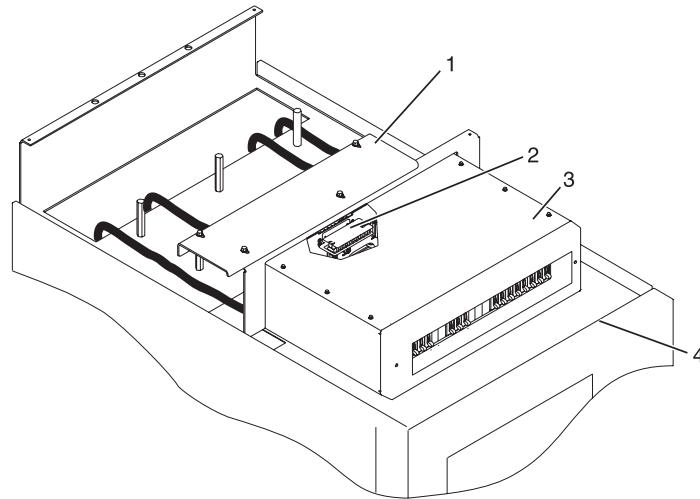

- 1 Cable channel cover
- 2 Terminal block (both sides)
- 3 Power distribution panel
- 4 Front of rack

Figure 18. Reinstalling the cable channel cover.

Installing the 7014-S11 rack

You might need to install the rack. Use the procedure in this section to perform this task.

If you are installing the 7014-S11 rack, complete the following steps:

1. Read the "Rack Safety Notices" on page 1.
2. Open all boxes that you received with your order.
3. Follow the unpacking instructions that came with the rack to unpack the boxes.
4. Complete a parts inventory before installing the rack by following these steps:
 - a. Locate the kitting report in an accessory box.
 - b. Ensure that you received all the parts that you ordered.

If there are incorrect, missing or damaged parts, contact:

- Your IBM reseller
 - <http://www.ibm.com/planetwide>: Locate your service and support telephone numbers
 - IBM Rochester Manufacturing Automated Information Line at 1-800-300-8751 (United States only)
5. Place the rack at the site you identified when completing your planning tasks.

Important: The 7014-S11 rack cannot be stacked and it is not designed to support equipment on top of the rack.

6. Detach the rack keys from the door if they are still present and place them in a secure location.
7. Tighten the caster locking screws on each of the four casters to prevent the rack cabinet from moving.

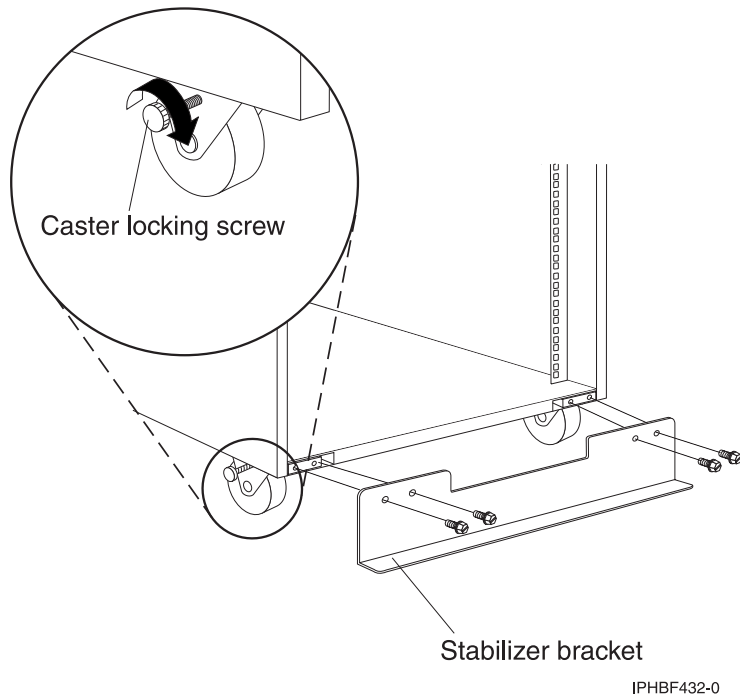

Figure 19. Tightening the caster locking screw and attaching the stabilizer.

8. Attach the stabilizer bracket by doing the following:
 - a. Locate the four screws that came with the bracket.
 - b. Align the holes on the bracket with the four holes on the rack cabinet. Make sure the lip of the stabilizer bracket is facing away from the rack cabinet.
 - c. Attach each of the four screws securely.

Important: You must extend the stabilizer bracket when installing heavy devices or extending existing devices on the rails in the rack cabinet.

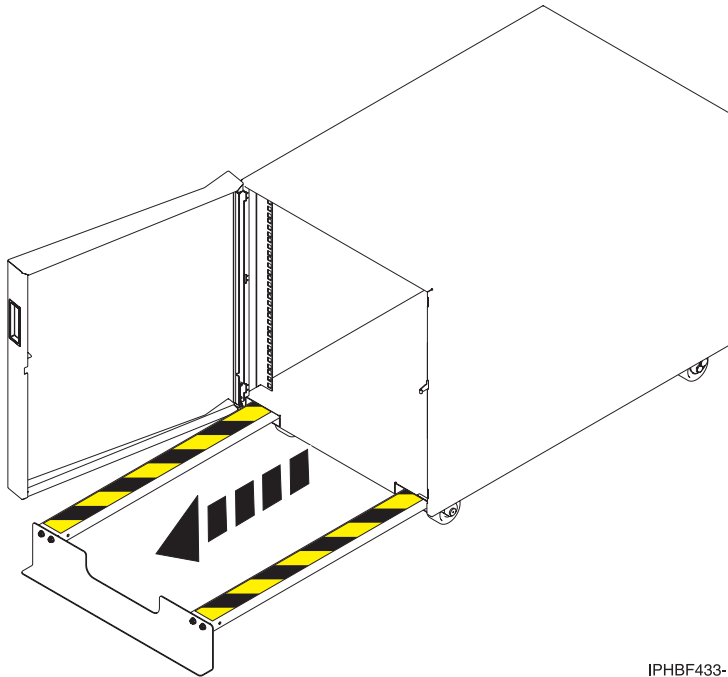

Figure 20. Extending the stabilizer bracket.

9. To attach the cage nuts, see “Installing the cage nuts in a 7014-S25 or 7014-S11 rack” on page 28 and return to these instructions.

Note: You must use cage nuts to install optional devices that do not have threaded holes. Cage nuts install on the inside of the rack-mounting flanges with either a mounting tool or flat-blade screwdriver.

10. If you need to install the system unit in the rack, go to Install the system unit or expansion unit into a rack. If your new system unit was preinstalled in the rack, return to the initial server setup checklist.

Note: The 7014-S11 rack supports a maximum of 400 pounds (181.4 kg) of installed equipment.

Installing the 7014-S25 rack

You might need to install the rack. Use the procedure in this section to perform this task.

If you are installing the 7014-S25 rack, complete the following steps:

1. Read the “Rack Safety Notices” on page 1.
2. Open all boxes that you received with your order.
3. Follow the unpacking instructions that came with the rack to unpack the boxes.
4. Complete a parts inventory before installing the rack:
 - a. Locate the kitting report in an accessory box.
 - b. Ensure that you received all the parts that you ordered.

If there are incorrect, missing or damaged parts, contact:

- Your IBM reseller
 - <http://www.ibm.com/planetwide>: Locate your service and support telephone numbers
 - IBM Rochester Manufacturing Automated Information Line at 1-800-300-8751 (United States only)
5. Place the rack at the site you identified when you completed your planning tasks for this order.

Note: The 7014-S25 rack cannot be stacked, and it is not designed to support equipment on top of the rack.

6. Detach the rack keys from the door if they are still present and place them in a secure location.
7. Tighten the caster locking screws on each of the two front casters to prevent the rack cabinet from moving.
8. Locate and lower the four leveling feet until each pad touches the floor, using the small end of the wrench included in the hardware kit.

Note: The leveling feet only need to touch the floor so the rack cabinet does not move. The casters support the weight of the rack cabinet.

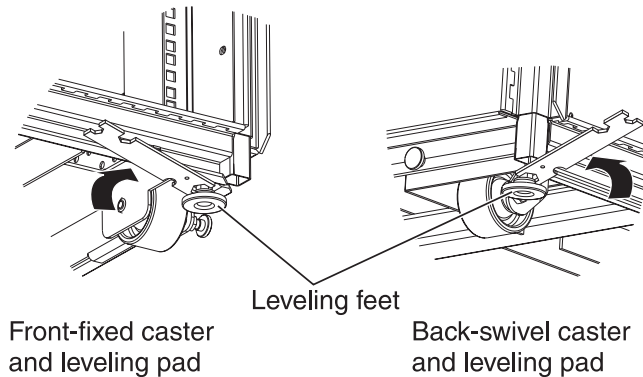

IPHBF401-1

Figure 21. Lowering the leveling feet.

9. Attach the stabilizer bracket by doing the following:
 - a. Locate the three screws that came with the stabilizer bracket.
 - b. Align the holes on the tip plate with the three holes on the rack cabinet. Make sure the lip of the stabilizer bracket is facing away from the rack cabinet.

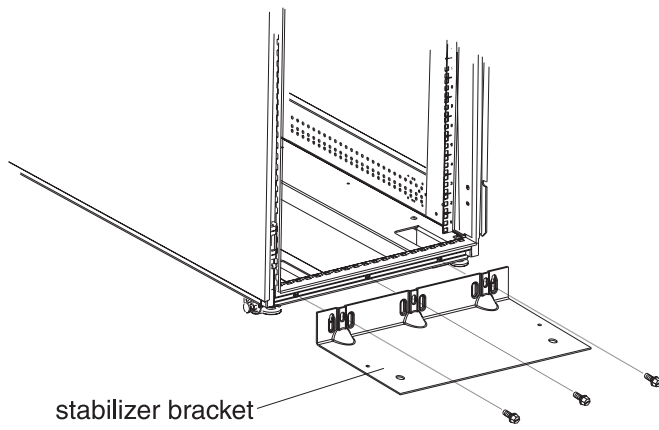

IPHBF402-2

Figure 22. Installing the stabilizer bracket.

- c. Attach each of the three screws securely.

Note: If necessary, the rack cabinet may be bolted to the floor through the holes in the stabilizer bracket.

10. To review the procedure for inserting the cage nuts, see “Installing the cage nuts in a 7014-S25 or 7014-S11 rack” on page 28.

Note: You must use cage nuts to install optional devices that do not have threaded holes. Cage nuts are installed on the inside of the rack mounting flanges with either a cage-nut-insertion tool or flat-blade screwdriver.

11. If you need to install the system unit in the rack, go to Install the system unit or expansion unit into a rack. If your new system unit was preinstalled in the rack, return to the initial server setup checklist.

Note: The 7014-S25 rack supports a maximum of 1200 pounds (544.3 kg) of installed equipment.

Removing and replacing 7014-S25 doors

You might need to remove and replace a rack door. Use the procedures in this section to perform this task.

To remove a 7014-S25 front door, follow these steps.

1. Unlock and open the door.

Note: This action will release the door from the hinges.

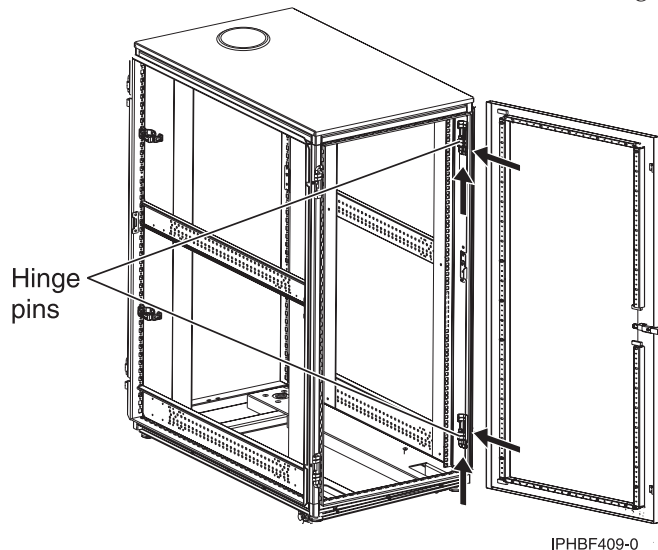

Figure 23. Removing the door.

2. Grasp the door firmly with both hands and pull it away from the hinges.

Installing a 7014-S25 front door:

1. Grasp the door firmly with both hands and align the slots in the door with the hinge pins.
2. While holding the door firmly with one hand, push each of the hinge pins down into the closed position.

Removing and replacing 7014-S25 side panels

You might need to remove and replace a side panel on the rack. Use the procedures in this section to perform this task.

The 7014-S25 standard racks come with side panels installed. Remove the side panels from a rack before you install or remove optional devices.

1. Unlock the side panels by pressing out on both locking latches to release the latches.

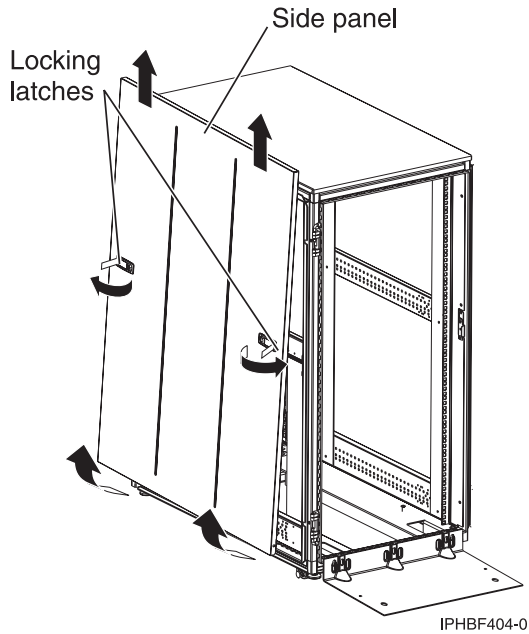

IPHBF404-0

Figure 24. Removing the side panel.

2. Tilt the bottom of the side panel slightly toward you.
3. Lift the side panel away from the ridge on the top of the rack.
4. Repeat this procedure for the other side panel.

Replacing a 7014-S25 side panel:

1. Tilt the bottom of the side panel slightly toward you.
2. Place the top of the side panel onto the ridge on the top of the rack.

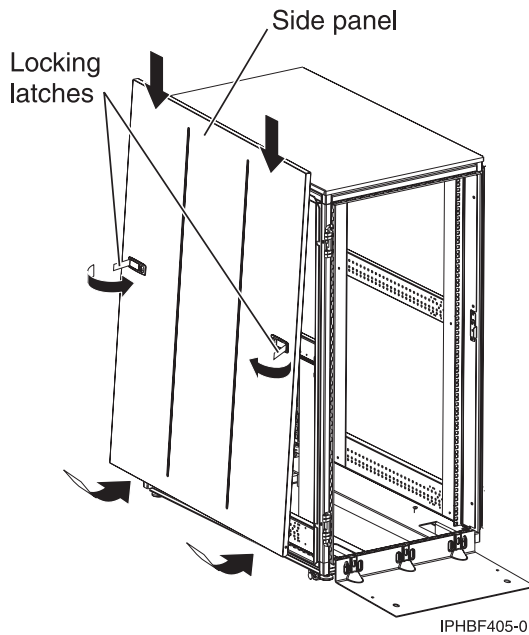

IPHBF405-0

Figure 25. Replacing the side panel.

3. Slide the bottom of the side panel into place and close the locking latches.

Installing the cage nuts in a 7014-S25 or 7014-S11 rack

You might need to install cage nuts into a rack. Use the procedure in this section to perform this task.

You must use cage nuts for all optional devices that do not have threaded holes. A supply of cage nuts is included with the rack. Cage nuts are installed on the inside of the rack-mounting flanges with either the cage-nut-insertion tool or a flat-blade screwdriver. The cage-nut-insertion tool comes with the rack and some optional devices.

To install the cage nuts with the cage-nut-insertion tool, complete the following steps.

1. Mark the precise place where you will mount optional equipment. For more information see, *Install the system unit or expansion unit into a rack* then return to these instructions.
2. To insert a cage nut using the cage-nut-insertion tool, complete the following steps:
 - a. From the inside of the rack-mounting flange, insert one edge of the cage nut into the hole.

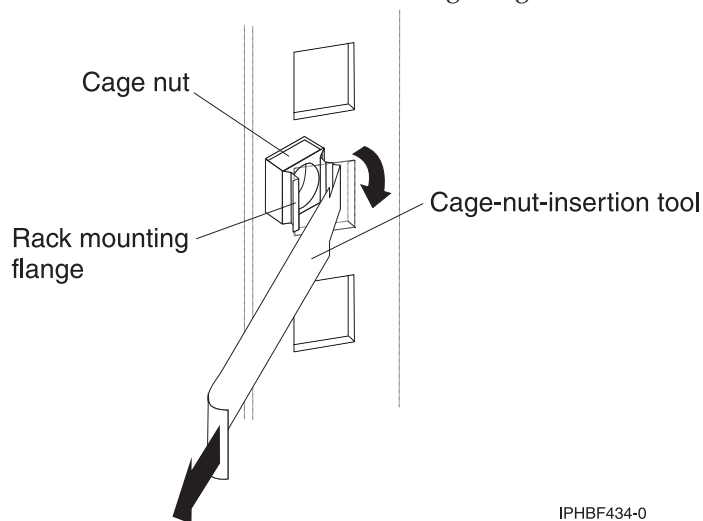

Figure 26. Inserting a cage nut using the insertion tool.

- b. Push the tool through the hole and hook the other edge of the cage nut.
 - c. Pull the tool and the cage nut back through the hole.
3. Optional: To install the cage nut using a flat-blade screwdriver, complete the following steps:
 - a. Hold the cage nut in one hand, and compress the cage-nut clip with a flat-blade screwdriver.

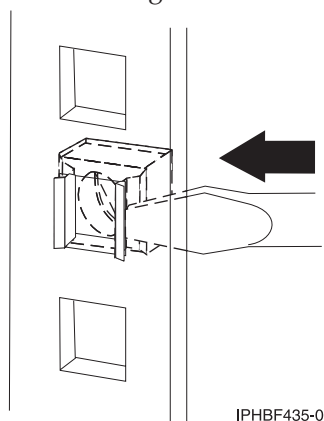

Figure 27. Inserting a cage nut using a flat-blade screwdriver.

- b. With the clip compressed, push the edge of the cage nut fully into the hole from the inside of the rack-mounting flange.
- c. Release the screwdriver pressure on the clip to lock the cage nut into place.

If you are installing the cage nuts as a part of installing a system unit into a rack, return to those instructions, or see *Install the system unit or expansion unit into a rack*.

Installing rack features

You might need to install a rack feature. This section includes procedures so that you can perform these tasks.

You can perform these tasks or contact a service provider to perform the tasks for you. You might be charged a fee by the service provider for this service.

Attaching the rack doors

You might need to attach the rack doors. Use the procedure in this section to perform this task.

Depending on the model of the rack, the front door of a rack might be an optional feature. If your system already has the front door installed, or does not have a front door to install, skip this step.

The following types of front doors are available:

- The RS/6000[®] front door is attached to open in only one direction, from the right to the left, while you are facing the front of the rack.
- The eServer[™] pSeries[®] front door is attached to open either from the right to the left, or from the left to the right, while you are facing the front of the rack.
- The high-perforation front door is attached to open only in one direction, from the left to the right, while you are facing the front of the rack.

If you are attaching an RS/6000 or high-perforation front door, see “Attaching an RS/6000 or high-perforation front door” on page 32. If you are attaching a pSeries front door, go to “Attaching a pSeries rack front door” on page 32.

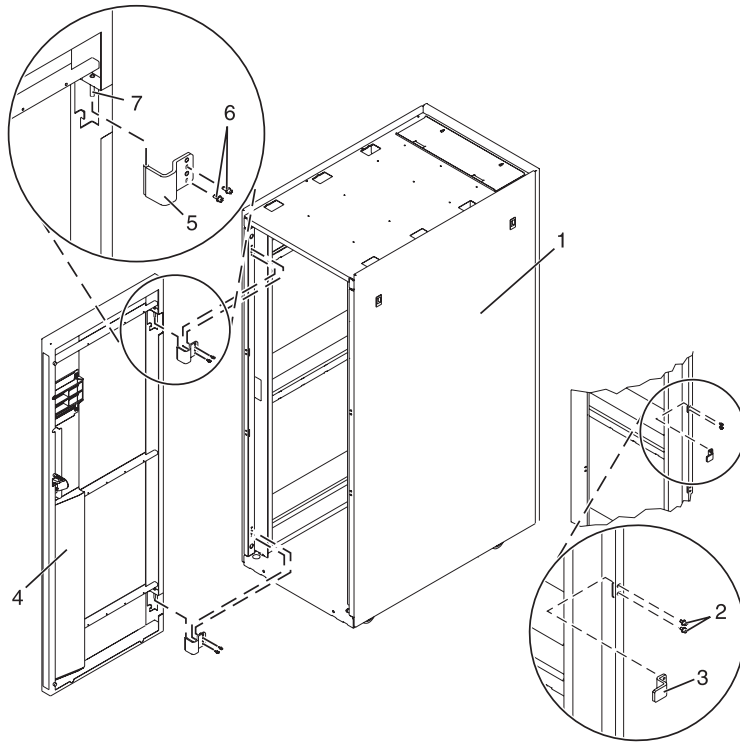

Figure 28. Attaching the rack door.

- | | |
|-------------------------------------|-------------------------------|
| 1 Rack chassis | 5 Door hinge |
| 2 Front door latch retaining screws | 6 Door hinge retaining screws |
| 3 Front door latch | 7 Hinge pin |
| 4 Rack front door | |

Removing and replacing 7014-T00, 7014-T42, 0551, or 0553 side panels

You might need to remove and replace a side panel on a rack. Use the procedure in this section to perform this task.

The rack might have optional side panels. To remove and replace a side panel, complete the following procedure:

1. Unlock the side panels by pressing down on both locking latches to release the latches.

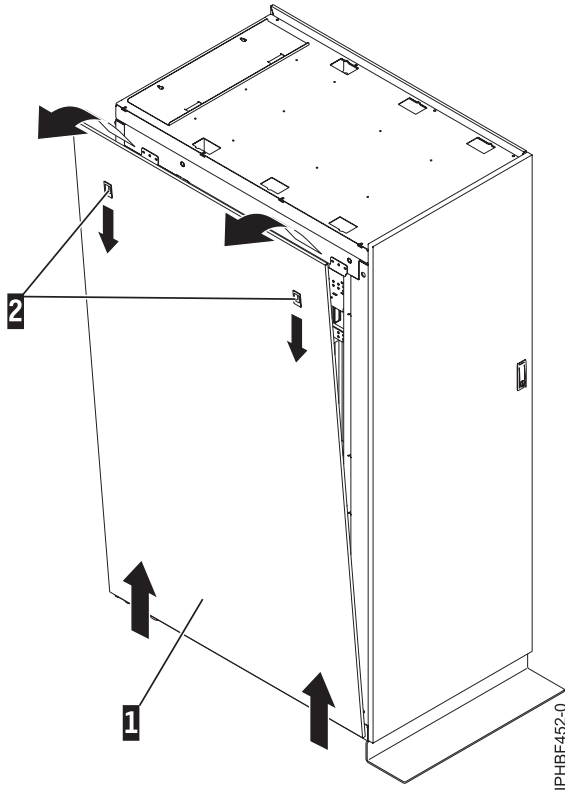

Figure 29. Removing the side panel.

- Note:** If your rack uses a ruggedized kit, you must remove the securing screw to allow each side panel to be removed. Refer to “Releasing the side panel with a ruggedized kit” on page 61.
2. Tilt the top of the side panel slightly toward you.
 3. Lift the side panel away from the ridge on the bottom of the rack.
 4. Repeat this procedure for the other side panel.

Replacing a 7014-T00, 7014-T42, 0551, or 0553 side panel:

You might need to replace a side panel on a rack. Use the procedure in this section to perform this task.

1. Tilt the top of the side panel slightly toward you.

2. Place the bottom of the side panel onto the ridge on the bottom of the rack.

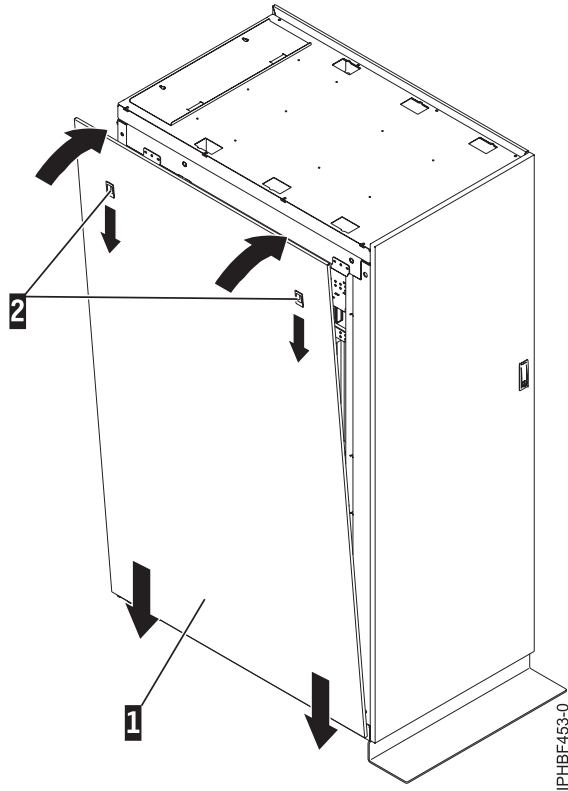

Figure 30. Replacing the side panel.

3. Slide the top of the side panel into place and close the locking latches.

Note: If your rack uses ruggedized kit, you must install a securing screw into each side panel that was installed. Refer to “Ruggedized kit” on page 60.

Attaching a pSeries rack front door

You might need to attach a front door to a rack. Use the procedure in this section to perform this task.

To install a pSeries rack front door to open from right to left, follow the installation steps described in “Attaching an RS/6000 or high-perforation front door.”

To install a pSeries rack front door to open from left to right, refer to the previous illustration, and perform the following steps:

1. Read the “Rack Safety Notices” on page 1.
2. Remove the door latch and cover plate and reinstall them on the opposite side of the door.
3. Remove the door hinges and reinstall them on the opposite side of the door.
4. Install the rack latch on the opposite side of the rack.
5. Align the front door with the hinge pins, and lower the door into position.
6. Adjust the latch so the door latches securely.

Attaching an RS/6000 or high-perforation front door

You might need to attach a front door to the rack. Use the procedure in this section to perform this task.

To install the high-perforation front door, do the following:

1. Read the “Rack Safety Notices” on page 1.

2. Remove the top, left, and right trim panels.

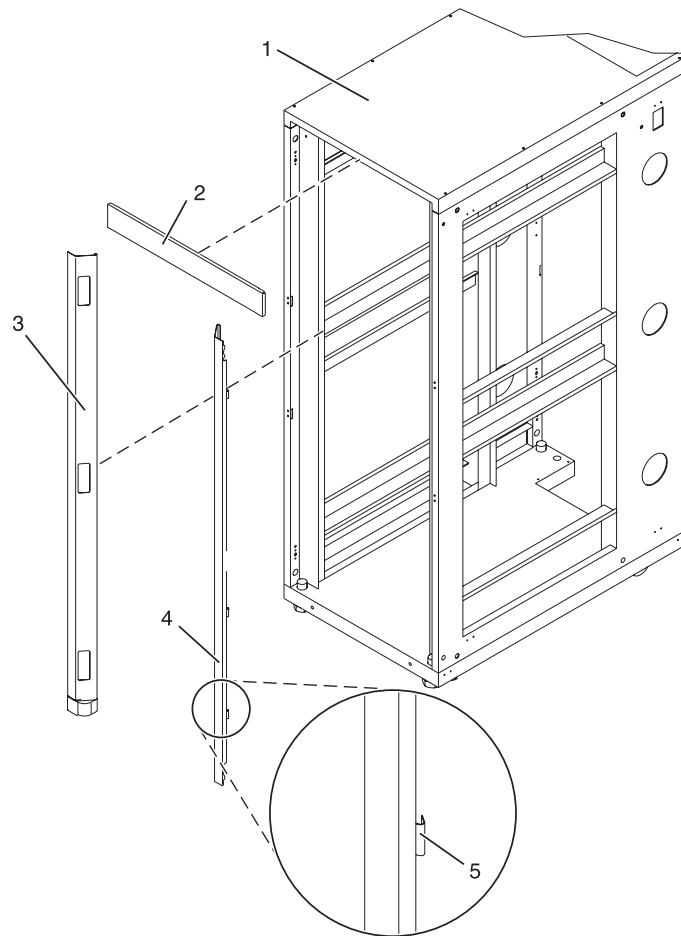

- 1 Rack chassis
- 2 Top trim panel
- 3 Left side trim panel
- 4 Right side trim panel
- 5 Spring clip

Figure 31. Removing the trim panels.

3. Install the door latch on the right and the door hinges on the left.
4. Align the lower hinge pin on the front door with the hinge, then partially insert the hinge pin into the hinge.
5. Align the upper hinge pin with the hinge, then seat the hinge pins into both the upper and the lower hinges.
6. For an RS/6000 front door, align the front door with the hinge pins, and lower the door into position.
7. For a high-perforation front door, align the door over the rack hinge, then move up the hinge pin on the door, and lower the hinge pin into the hinge.
8. Adjust the latch so the door latches securely.

Note: If you are going to mount a door that opens from left to right, the components are mounted to the opposite side of the rack. The door latch will also need to be moved to the opposite side of the door.

Installing the Rear Door Heat Exchanger for 7014-T42

You might need to install the rear door Heat Exchanger. Use the procedure in this section to perform this task.

Depending on the model of the rack, the IBM Rear Door Heat Exchanger for 7014-T42 might be an optional feature.

Note: To complete this procedure, it is suggested that you use two people to attach the door assembly to the rack.

Before you can install the Heat Exchanger, you must have prepared the facility according to the Planning for the installation of rear-door heat exchangers. This guide includes the water-quality and water-supply specifications. You can install the Heat Exchanger while devices in the rack cabinet are operating, but the optimum time for the installation is during a scheduled downtime or maintenance period.

Installing the Heat Exchanger consists of the following major tasks:

1. Attaching the door assembly to the rack.
2. Connecting the water-supply hose from the pump unit to the Heat Exchanger.
3. Filling the Heat Exchanger with water, which includes purging air from the Heat Exchanger manifolds and connecting the return hose.
4. Securing the hoses and the door assembly.

Tip: Connecting the hoses from the pump unit to the Heat Exchanger (tasks 2 and 3) creates the required secondary loop in the water-circulation system. See the Planning for the installation of rear-door heat exchangers for information about primary and secondary loops in a water-circulation system.

After you unpack the Heat Exchanger, make sure that you have the following items that come in the option kit:

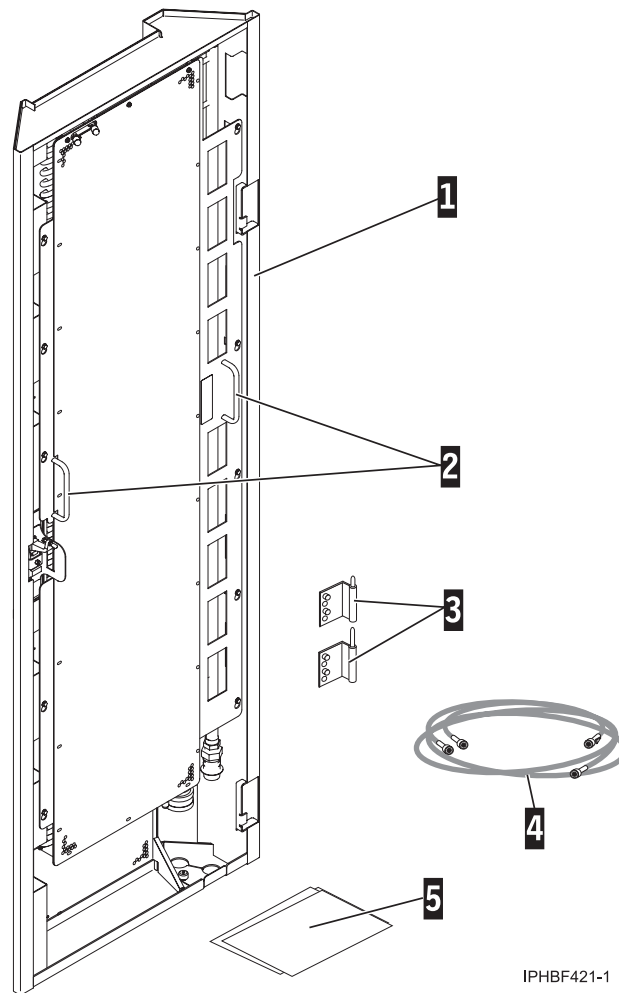

IPHBF421-1

- 1 Door assembly
- 2 Handles
- 3 Hinge kit
- 4 Air-purging tool
- 5 Documentation

Figure 32. Heat Exchanger parts.

In addition to the items that come in the option kit, you will need the following items:

- 7-mm wrench to remove and install the hinges.
- 8-mm wrench to adjust the latch mechanism.
- The hose assemblies that are described in the Planning for the installation of rear-door heat exchangers. The hose assemblies connect the Heat Exchanger to the pump unit, creating the secondary loop.

Note: For a non-raised floor, you must use the elbow-style hose assemblies that are described in the Planning for the installation of rear-door heat exchangers.

- An enclosed container with a capacity of at least 2 liters (approximately 2 quarts). Use the container to catch water that escapes as you purge air from the Heat Exchanger while filling the Heat Exchanger with water.

Note: Although the likelihood of water exposure is small, you might prefer to place some water-absorbent material beneath the door assembly as a general practice when performing procedures on the Heat Exchanger.

Attaching the Heat Exchanger assembly to the rack

You might need to attach the Heat Exchanger to the rack. Use the procedure in this section to perform this task.

Note: To complete this procedure, it is suggested that you use two people to attach the door assembly to the rack.

To attach the Heat Exchanger door to the rack, complete the following steps:

1. Remove the Heat Exchanger door assembly and all parts from the packaging.
2. Unlock and open the existing rear door 1 if applicable.

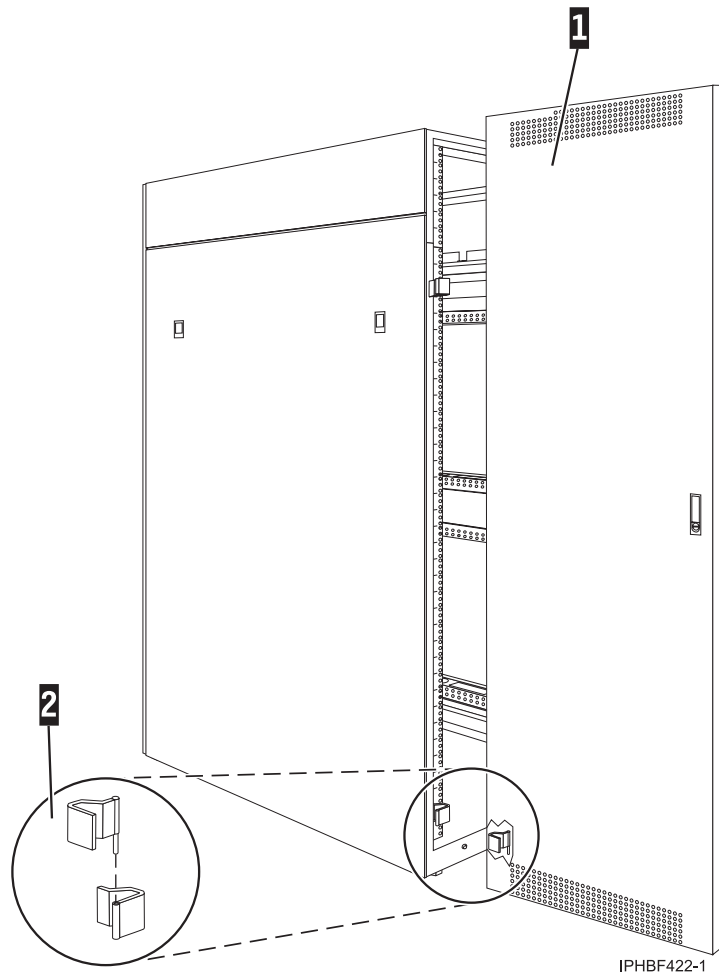

Figure 33. Existing rear rack door.

3. Grasp the door 1 firmly with both hands and lift it upward and away from the hinges 2. Store the door in a safe place for possible future use.
4. Open the hinge kit that comes with the Heat Exchanger.

Note: One hinge has a shorter pin 3 and the other hinge has a longer pin 4.

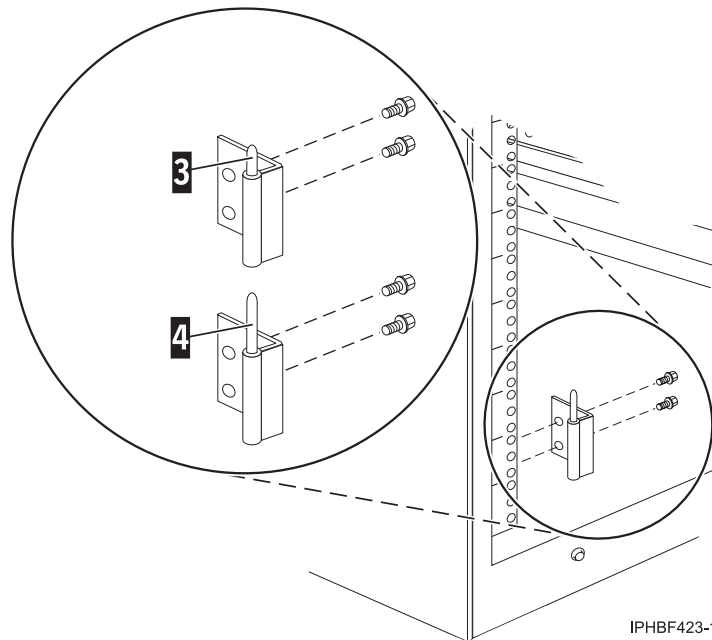
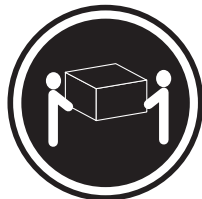

Figure 34. Door pins.

5. Remove the two screws that hold the top rear hinge 4 in place on the rack cabinet.
6. Remove the hinge and then install the new hinge with the short pin in the same location on the rack cabinet.
7. Remove the two screws that hold the bottom hinge 3 in place on the rack cabinet.
8. Remove the hinge and then install the new hinge with the long pin in the same location on the rack cabinet. Store both old hinges with the old rear door for possible future use.
9. Position the Heat Exchanger door at a 90 degree angle to the rack cabinet.

Note: Use the lift handles 5 to maneuver the door.



≥ 18 kg (39.7 lb)



≥ 32 kg (70.5 lb)



≥ 55 kg (121.2 lb)

IPHBF442-0

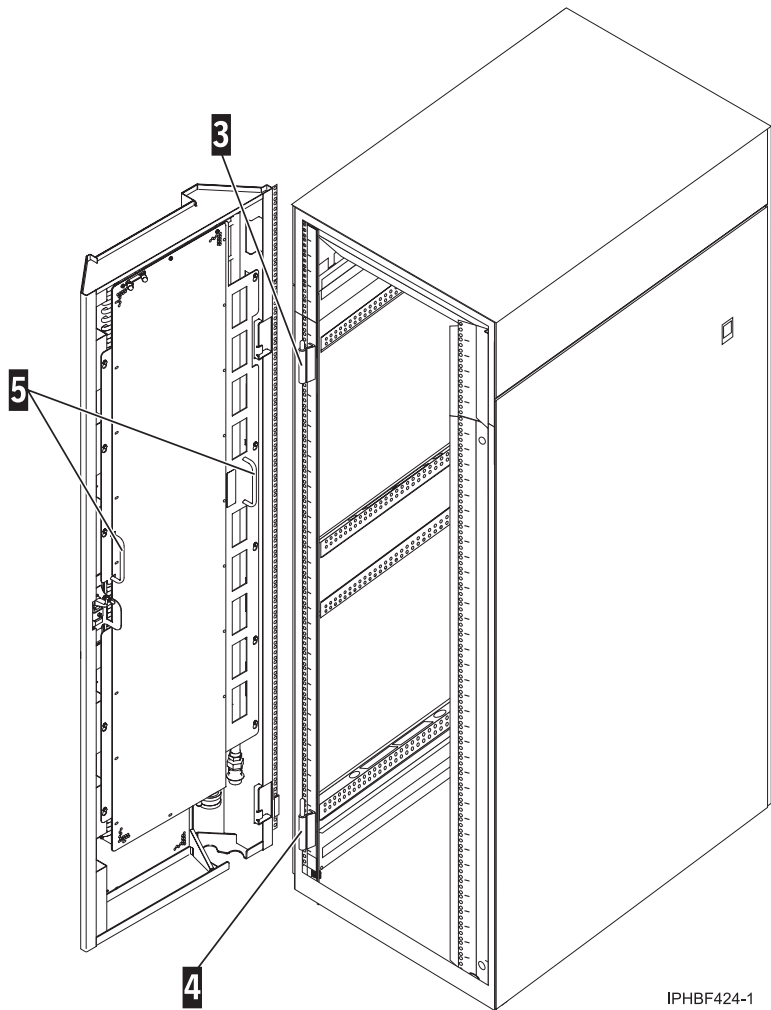

Figure 35. Positioning the Heat Exchanger door.

Attention: Make sure that you engage the bottom hinge pin 4 first when you install a rear door on the rack cabinet.

10. Place the Heat Exchanger door so that the bottom hinge pin 4 on the rack cabinet goes into the locator hole in the bottom hinge area of the door. While keeping the door on the bottom hinge pin 4, lift the door slightly and place the top hinge area of the door on the top hinge pin 3 on the rack cabinet; then, lower the door onto the hinge pins.
11. Close and adjust the latch mechanism so that all the door gaskets touch the rack components and compress to a gap of approximately 7 mm (0.25 in.) on all four sides of the door.

Connecting the water supply

You might need to connect the water supply to the Heat Exchanger. Use the procedure in this section to perform this task.

To connect the secondary-loop water supply to the Heat Exchanger, complete the following procedure:

Important: Exerting significant upward pressure on the door while connecting hoses can cause the door to release from the upper rack hinge. Be careful not to lift the door off the top hinge during these

procedures. You can insert a blocking device, such as a piece of foam or metal, into the door below the top hinge during procedures that involve connecting the water supply to prevent the door from coming off its top hinge.

1. Open the door to a 90-degree angle.
2. Remove the screw 1 that is securing the hose retention plate 2 to the door.

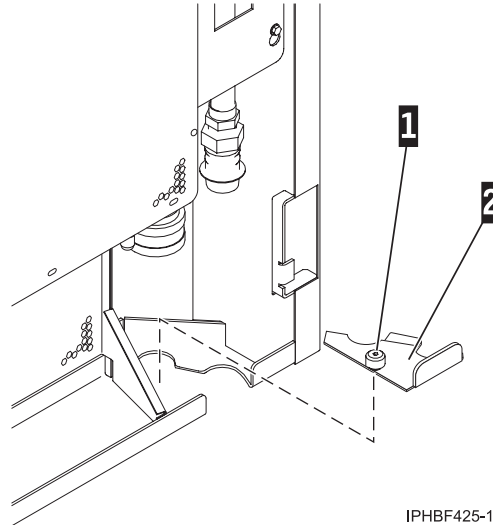

Figure 36. Removing the hose retention plate.

3. If the rack cabinet is on a raised floor, remove the floor tile that the hoses will pass through. Pull the hoses up to provide slack.
4. Attach the water-supply hose 4 to the female coupling (on the supply manifold) 3 on the Heat Exchanger.

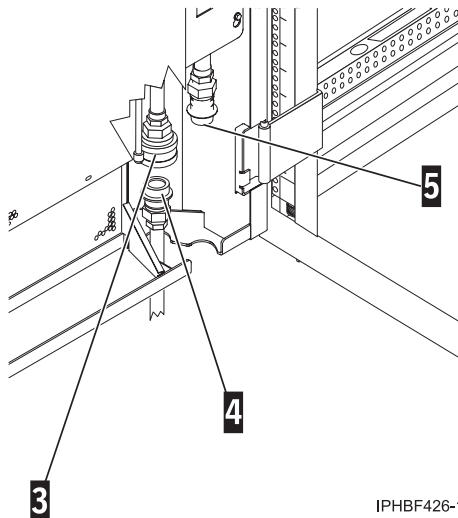

Figure 37. Attaching the supply hose.

- a. Align the male hose coupling with the female supply-manifold coupling.

Note: If the couplings are misaligned, it will be difficult to connect the hose.

- b. Move the female collar upward.
- c. Insert the male hose coupling. Exert upward pressure until the female collar moves downward and locks in place with an audible click. After the couplings are engaged but before the collar has locked into place, you can release the collar and use both hands to push the hose upward to lock the couplings.

Important: Do not connect the return hose until instructed to do so later in these instructions.

Filling the Heat Exchanger with water

You might need to fill the Heat Exchanger with water. Use the procedure in this section to perform this task.

To fill the Heat Exchanger with water for the first time, complete the following steps.

Attention: Wear safety goggles or other eye protection whenever you are filling, draining, or purging air from the Heat Exchanger.

1. Remove and retain the caps from the air-purging valves on the supply manifold **1** and from the return manifold **2**.

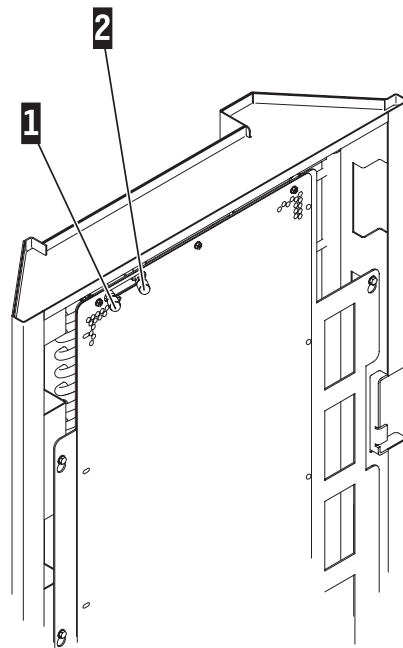
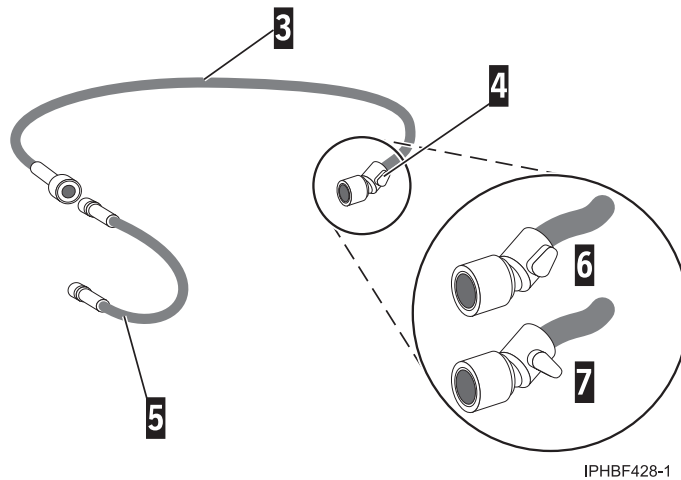

Figure 38. Removing the valve caps.

2. Attach one end of the air-purging hose **3** to the leftmost (supply) air-purging valve **1**. Make sure that the air-purging tool handle **4** is in the closed position (perpendicular to the hose) **7**.

Note: The six-inch extension hose **5** for the air-purging tool is not required for this procedure, but the extension hose can be attached if additional length is required.



IPHBF428-1

Figure 39. Air-purging hose.

3. Place the other end of the air-purging tool into the two-liter container to catch the water and air bubbles that escape during the filling procedure.
4. Turn on the flow of water to the Heat Exchanger.

Note: Depending on your facility, this might mean turning on the pump unit, opening a valve at the pump unit, or a similar action.

5. Turn the air-purging tool handle 4 to the open position 6 (parallel to the hose). Water that is mixed with air will begin to spray into the container when the manifold is almost full.
6. When there is a steady stream of water from the air-purging tool into the container, turn the handle 4 on the supply manifold to the closed position. Disconnect the air-purging hose 3 and move the hose to the to the air-purging valve on the return manifold 2.

Attention: If water drips from an air-purging valve on the door after you remove the air-purging tool, reattach the air-purging tool and then disconnect the tool again to properly reseal the seal.

7. Turn the air-purging tool handle 4 to the open position 6. When there is a steady stream of water from the air-purging hose, turn the tool handle to the closed position 7. Then, disconnect the hose and set it aside temporarily.
8. Attach the return hose 9 to the male coupling 8 (on the return manifold) on the Heat Exchanger.

Tip: To make it easier to attach the return hose, turn off the water supply temporarily to remove water pressure. After attaching the return hose, turn on the water supply again.

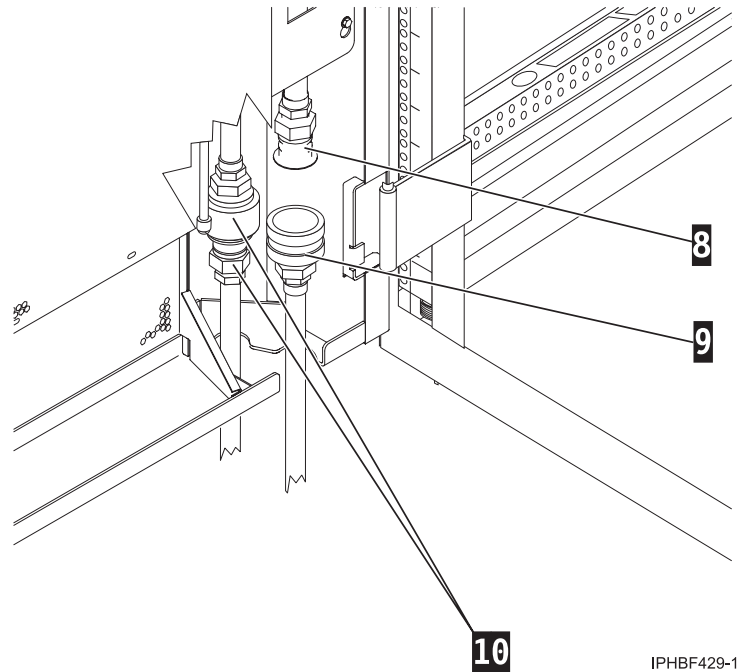

Figure 40. Attaching the return hose.

- a. Align the female hose coupling 9 with the male return-manifold coupling 8.

Note: If the couplings are misaligned, it will be difficult to connect the hose.

- b. Move the female collar downward and raise the female coupling onto the male coupling 8.
- c. Exert upward pressure until the female collar moves upward and locks in place with an audible click.

Note: After the couplings are engaged but before the collar has locked into place, you can release the collar and use both hands to push the hose upward to lock the couplings.

9. Attach the air-purging hose to the supply air-purging valve 1 again and purge the air from the valve (repeat steps 3, 5, and 6). Purge the air from the return valve 2 again.

Note:

- Water will spray into the container immediately at this point.
- Air in a manifold causes a splashing or gurgling sound. If this sound is present, repeat air-purging procedure on both valves.

10. Feel the bottom and top of the manifolds (the vertical copper-supply and copper-return pipes on the Heat Exchanger) to see if they are cool. If they are cool to the touch, chilled water is flowing correctly through the Heat Exchanger.
11. Install the valve caps onto the air-purging valves and hand-tighten the caps to provide a secondary seal.

Completing the installation of the Heat Exchanger

You might need to complete the installation of the Heat Exchanger. Use the procedures in this section to perform this task.

To complete the installation of the Heat Exchanger, follow these steps:

1. Reinstall the hose-retention plate by completing the following steps:

- a. Slide the middle flange 1 of the hose-retention plate 2 below the matching lip of the corresponding plate and wiggle the plate into place.
- b. Tighten the captive screw 3 to secure the hose-retention plate 2 to the door.

Tip: To make it easier to attach the return hose, turn off the water supply temporarily to remove water pressure. After attaching the return hose, turn on the water supply again.

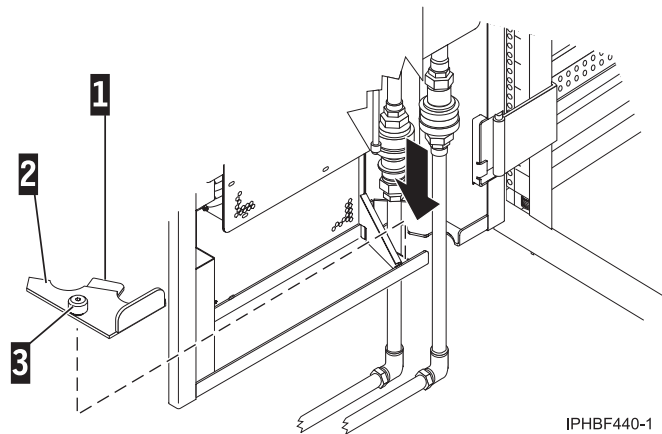

Figure 41. Reinstalling the hose retention plate.

2. Install the floor tile (on a raised floor) 4 or route the hoses away from the rack cabinet (on a non-raised floor) 5 as shown in the following figure.

Note: To make it easier to attach the return hose, turn off the water supply temporarily to remove water pressure. After attaching the return hose, turn on the water supply again.

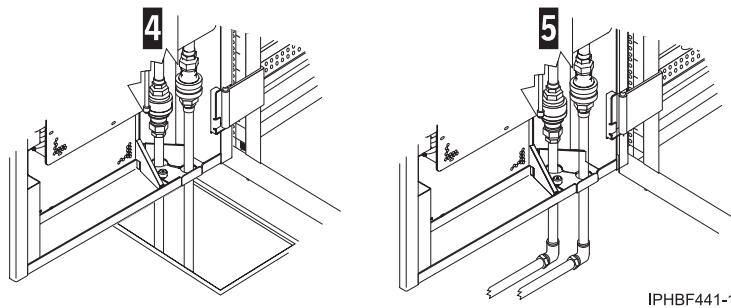

Figure 42. Installing the floor tile or routing hoses.

3. Close and latch the door.

Note: If the rack cabinet is on a non-raised floor 5, you might have to manually keep the hoses parallel and move them back into position as you close the door.

4. Check the Heat Exchanger after several hours of operation. If there is a splashing or gurgling sound, repeat the "Purging air from the Heat Exchanger" on page 45 procedure on both valves (trapped air from the hoses might have migrated to the Heat Exchanger).
5. Check the Heat Exchanger for air in the manifolds again after one month of operation, to ensure that the Heat Exchanger is filled correctly.

Heat Exchanger maintenance procedures

You might need to perform maintenance procedures. Use the procedure in this section to perform this task.

The following illustration shows the locations of the components on the rear door Heat Exchanger.

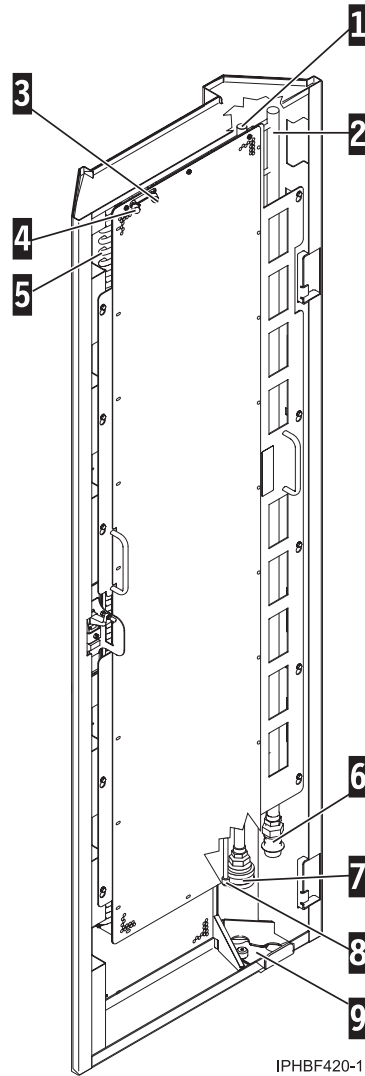

Figure 43. Heat Exchanger door components.

- 1 supply manifold
- 2 return manifold
- 3 air-purging valve (return manifold)
- 4 air-purging valve (supply manifold)
- 5 fins (behind protective barrier)
- 6 male coupling (return manifold)
- 7 female supply
- 8 drain
- 9 retention plate

Tip: Although the likelihood of water exposure is small, you might prefer to place some water-absorbent material beneath the door assembly as a general practice when performing procedures on the Heat Exchanger.

Purging air from the Heat Exchanger:

You might need to purge air from the Heat Exchanger. Use the procedure in this section to perform this task.

Perform the following procedure as part of regular maintenance, or if you hear a splashing or gurgling sound from the manifolds.

Attention: Wear safety goggles or other eye protection whenever filling, draining, or purging air from the Heat Exchanger.

1. Remove and retain the caps from the air-purging valves on the supply manifold **1** and the return manifold **2**.

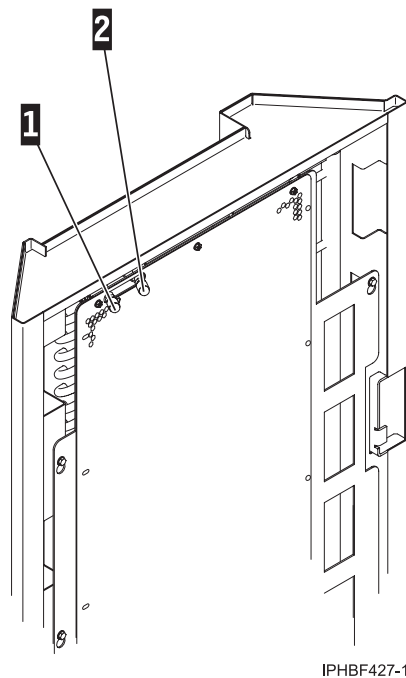

Figure 44. Removing the valve caps.

2. Attach one end of the air-purging hose **3** to the leftmost (supply) air-purging valve **1**. Make sure that the air-purging tool handle **4** is in the closed position (perpendicular to the hose) **7**.

Note: The 6-inch extension hose **5** for the air-purging tool is not required for this procedure, but it can be attached if additional length is required.

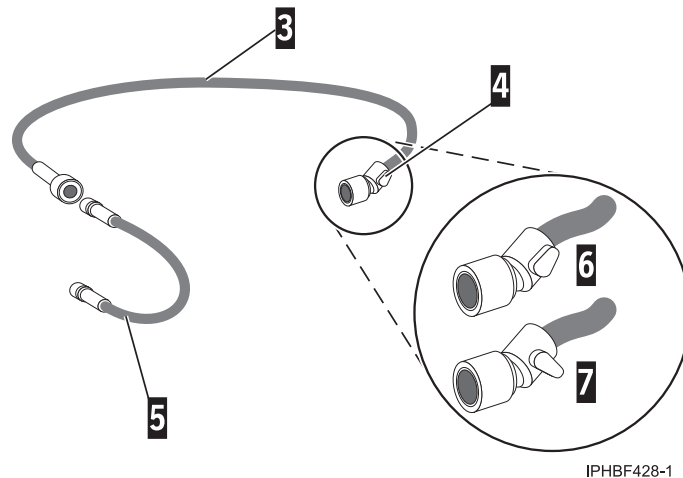

Figure 45. Air-purging tool.

3. Place the other end of the air-purging tool into the two-liter container to catch the water and air bubbles that escape during the filling procedure.
4. Turn the air-purging tool handle to the open position (parallel to the hose) 6. Water that is mixed with air will begin to spit into the container.
5. When there is a steady stream of water from the air-purging tool into the container, turn the tool handle 4 to the closed position 7. Disconnect the air purging hose 3 and move the hose to the to the air-purging valve for the return manifold 2.

Attention: If water drips from an air-purging valve after you remove the air-purging tool, reattach the tool and disconnect it again to properly reseal the seal.

6. Turn the air-purging tool handle 4 to the open position 6. When there is a steady stream of water from the air-purging hose, turn the tool handle to the closed position. Disconnect the hose and set it aside.

Note: Air in a manifold causes a splashing or gurgling sound. Repeat the air-purging procedure on both the supply and return valves if this sound is present.

7. Install the caps onto the air-purging valves and hand-tighten the caps to provide a secondary seal.

Draining the Heat Exchanger:

You might need to drain the Heat Exchanger. Use the procedure in this section to perform this task.

Perform this procedure before having the Heat Exchanger removed from the rack cabinet or when directed to do so by IBM Service. The drain port is at the bottom of the Heat Exchanger, near the supply and return couplings.

Attention: Wear safety goggles or other eye protection whenever filling, draining, or purging air from the Heat Exchanger.

Tip: Although the likelihood of water exposure is small, you might prefer to place water-absorbent material beneath the door assembly as a general practice when draining the Heat Exchanger.

To drain water from the Heat Exchanger, complete the following procedure:

1. Shut off the flow of water at the source.

Note: Depending on your facility, this might mean turning off the pump unit, closing a valve at the pump unit, or a similar action.

2. Open the door assembly to a 90-degree angle.
3. Unscrew the captive screw 1 on the hose-retention plate 2 as shown in the following figure.

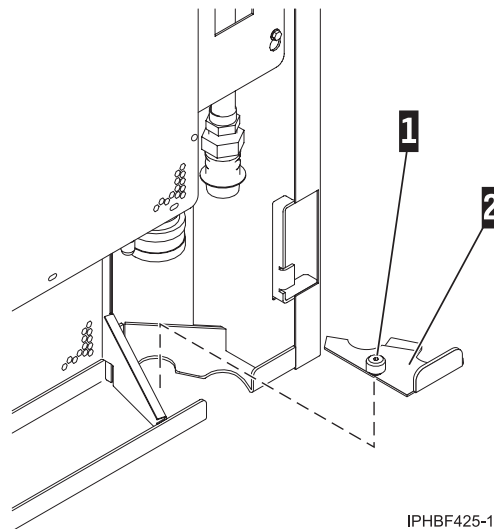

Figure 46. Removing the hose retention plate.

4. Lift the plate out of the door assembly.
5. Disconnect the supply hose 4 and return hose 5 from the Heat Exchanger.

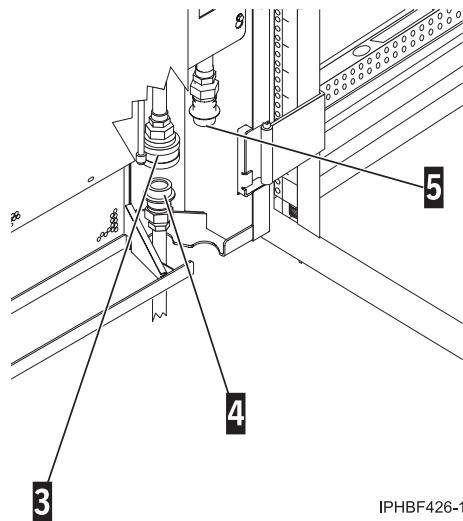

Figure 47. Disconnecting the return and supply hoses.

6. Remove the valve caps 1 and 2 from the air-purging valves and from the drain port 8 as shown in the following figure.

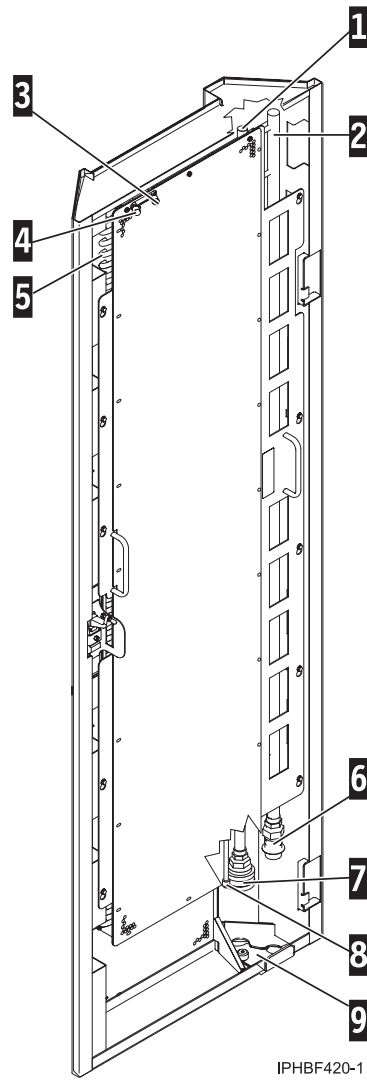

Figure 48. Removing the valve caps and drain port cap.

7. Remove the extension hose 5 from the air-purging tool 3, if it is connected. Make sure that the air-purging tool handle is in the closed position 6 as shown in the following figure.

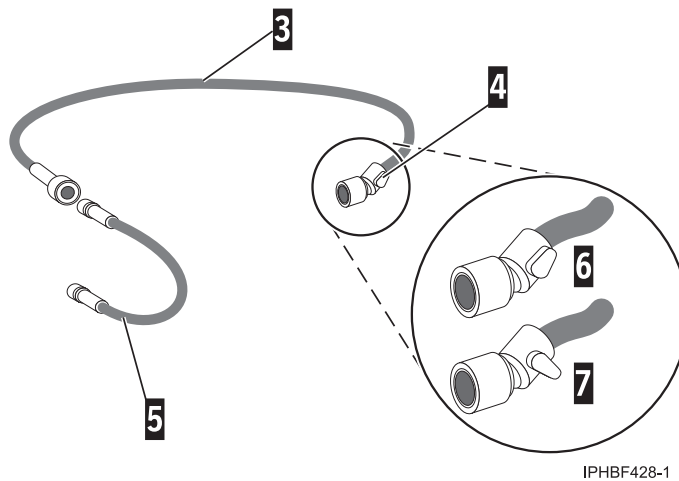

Figure 49. Removing the extension hose and attaching the air-purging tool to the drain port.

8. Attach the hose and valve portion of the tool to the drain port 8. Place the hose end into a container capable of holding at least 5.7 liters (1.5 gallons) of water.
9. Open the handle on the air-purging tool.
10. Attach the extension hose to one of the air-purging valves at the top of the Heat Exchanger to allow air to enter the manifolds.

Note: Instead of using the extension hose, if filtered and oil-free compressed air is available, you can attach the compressed-air hose to the air-purging valve to force water out of the exchanger. Keep the air pressure at 50 pounds per square inch (psi) or less to avoid excessive spray at the drain port.

11. When the water flow at the drain port stops, move the extension hose or compressed-air hose to the other air-purging valve and repeat the process.
12. When the water has drained completely from the manifolds, complete the following steps:
 - a. Remove the air-purging-tool extension hose or compressed-air hose from the air-purging valve.
 - b. Remove the air-purging tool hose and valve from the drain port 8.
 - c. Install the valve caps onto the air-purging valves and drain valve and hand-tighten the caps to provide a secondary seal.

Refilling after a leak in the system:

You might need to refill the Heat Exchanger. Use the procedure in this section to perform this task.

If a leak occurs, the action that you take depends on where the leak occurs. Choose from the following options:

- “Leaking from the water-supply circuit.”
- “Leaking from the Heat Exchanger” on page 50.

Leaking from the water-supply circuit:

You might need to attach the supply and return hoses. Use the procedure in this section to perform this task.

If a leak occurs in the user-supplied secondary loop of the water-circulation system, other than in the Heat Exchanger, repair the leak. Then complete the following procedure:

1. Reconnect the return 5 and supply hoses 4, if they are disconnected.

Use the following steps to attach the supply hose:

 - a. Align the male hose coupling 4 with the female supply-manifold coupling 3.

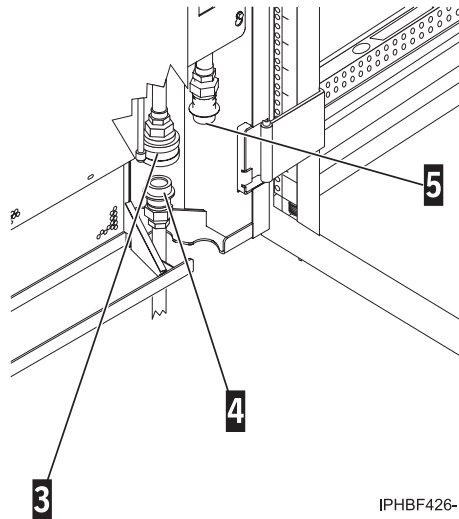

Figure 50. Attaching the supply hose.

Note: If the couplings are misaligned, it will be difficult to connect the hose.

- b. Move the female collar upward.
- c. Insert the male hose coupling 4. Exert upward pressure until the female collar moves downward and locks in place with an audible click. After the couplings are engaged but before the collar has locked into place, you can let go of the collar and use both hands to push the hose upward to lock the couplings.

Use the following steps to attach the return hose:

- a. Align the female hose coupling with the male return-manifold coupling.

Note: If you misalign the couplings, it will be difficult to connect the hose.

- b. Move the female collar downward and raise the coupling to the male coupling.
 - c. Exert upward pressure until the female collar moves upward and locks in place with an audible click. After the couplings are engaged but before the collar has locked into place, you can release the collar and use both hands to push the hose upward to lock the couplings.
2. Turn on the flow of water from the pump unit to the Heat Exchanger.
 3. Perform the air-purging procedure to remove any air that enters the Heat Exchanger from the hoses. Refer to “Purging air from the Heat Exchanger” on page 45.

Leaking from the Heat Exchanger:

You might need to replace the door because of a leak. Use the procedure in this section to perform this task.

Although a leak in the Heat Exchanger is unlikely, if it does occur, you must replace the door assembly. To replace the door assembly, complete the following steps:

Note: Call IBM Service to obtain a replacement rear door Heat Exchanger.

1. Drain the water from the Heat Exchanger. Refer to “Draining the Heat Exchanger” on page 46.
2. Replace the door assembly. Refer to “Replacing the Heat Exchanger door” on page 51.

3. Fill the replacement Heat Exchanger with water. Refer to “Connecting the water supply” on page 38 through the procedures for “Completing the installation of the Heat Exchanger” on page 42.

Replacing the Heat Exchanger door:

You might need to replace the Heat Exchanger door. Use the procedure in this section to perform this task.

Important: Before you remove the door assembly, make sure that the water has been drained from the Heat Exchanger and the hoses have been detached. Refer to “Draining the Heat Exchanger” on page 46 and “Attaching and detaching the hoses” on page 54.

To replace the Heat Exchanger door assembly from the rack cabinet, complete the following steps.

1. Open the door assembly from the rack to 90 degrees.
2. Grasp the door assembly firmly with both hands at the lift handles 5 and lift it upward and away from the hinges 3 and 4.



≥ 18 kg (39.7 lb)



≥ 32 kg (70.5 lb)

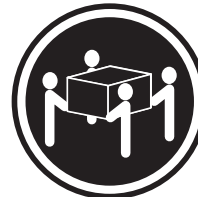

≥ 55 kg (121.2 lb)

IPHBF442-0

CAUTION:

Use safe practices when lifting. Using fewer than the required personnel to lift the door can result in personal injury.

3. Position the replacement door assembly at a 90-degree angle to the rack cabinet.

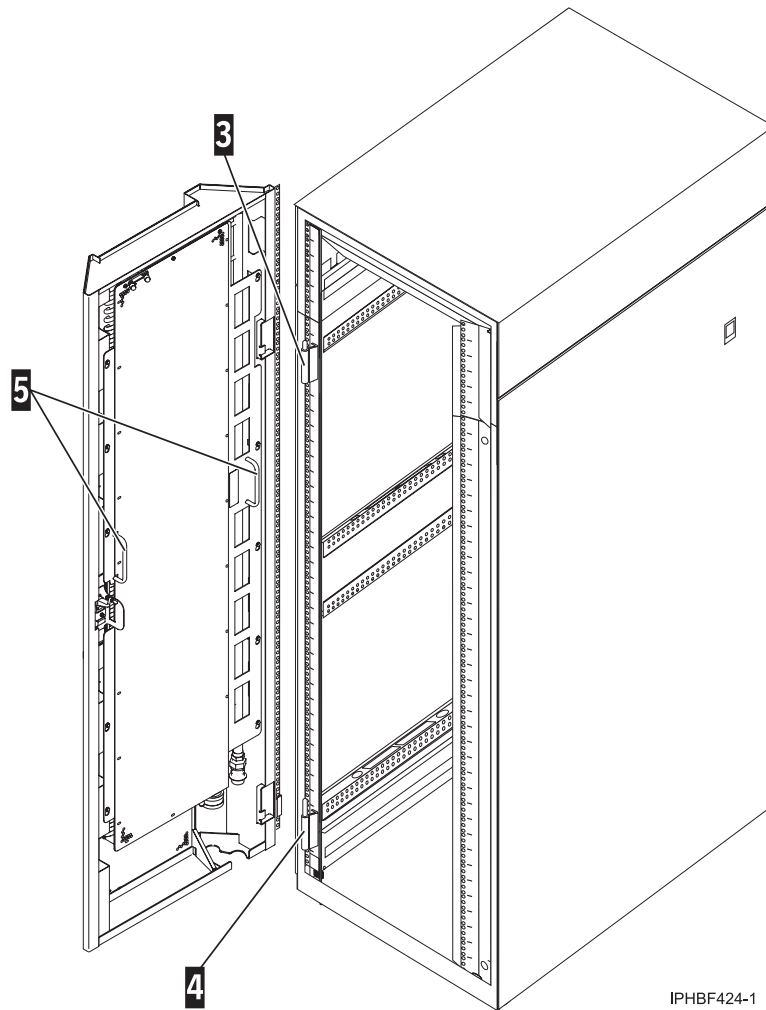

Figure 51. Lifting the door off its hinges.

4. Place the door so that the bottom hinge pin on the rack cabinet goes into the locator hole in the bottom hinge area of the door. While keeping the door on the bottom hinge pin, lift the door slightly and place the top hinge area of the door on the top hinge pin on the rack cabinet; then, lower the door onto the hinge pins.

Attention: Make sure that you engage the bottom hinge pin **4** first when you install a rear door Heat Exchanger on the rack cabinet. If the pin is not engaged, the door might fall.

5. Close and adjust the latch mechanism so that all the door gaskets touch the rack members and compress to a gap of approximately 7 mm (0.25 in.) on all four sides of the door.

Heat Exchanger common procedures:

You might need to perform common or maintenance procedures. Use the procedure in this section to perform this task.

The following procedures are used frequently when the Heat Exchanger is installed or as part of the maintenance procedures. Refer to these actions as you perform the installation and maintenance procedures.

Opening and closing the air-purging valves:

You might need to open and close the air purging valves. Use the procedure in this section to perform this task.

The air-purging valves are similar to bicycle or automobile tire valves. You must use the air-purging tool to open and close an air-purging valve.

The following illustration shows the air-purging tool.

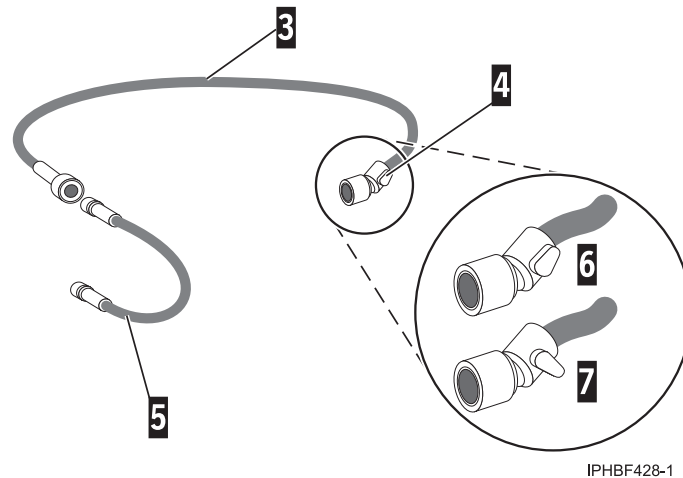

Figure 52. Air-purging tool.

When the air-purging tool handle is parallel to the tool hose, the tool is open 6 and air flows through the tool. When the tool handle is perpendicular to the tool hose 7, the tool is closed and air does not flow.

To open an air-purging valve, complete the following steps:

1. Unscrew the valve cap.
2. Screw the valve 4 of the air-purging tool onto the air-purging valve. The tool presses the valve pin inside the valve stem and allows air to flow.
3. Open the air-purging tool (turn the handle parallel to the tool hose) 6.

To close an air-purging valve, complete the following steps:

1. Close the air-purging tool (turn the handle perpendicular to the tool hose) 7.
2. Unscrew the valve of the air-purging tool 4 from the air-purging valve.
3. When you have completed the task that you are performing, such as draining the heat exchanger or purging air from it, install the valve cap onto the air-purging valve. The valve cap provides a secondary seal.

Removing and replacing the hose-retention plate:

You might need to remove or replace the hose-retention plate. Use the procedure in this section to perform this task.

You must remove the hose-retention plate before you connect the hose assemblies to or disconnect the hose assemblies from the manifold couplings.

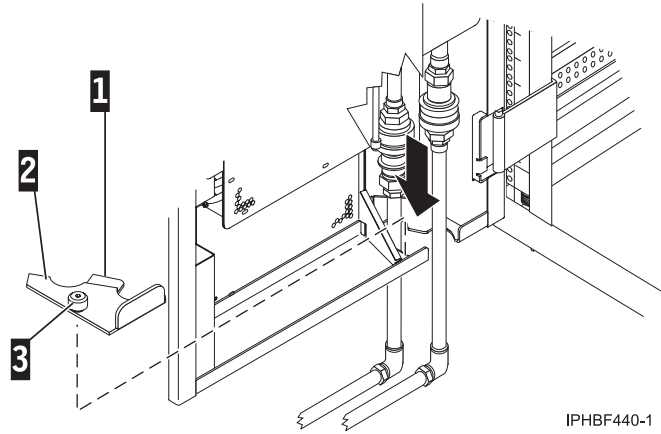

Figure 53. Removing and replacing the hose retention plate.

To remove the hose-retention plate, complete the following steps:

1. Open the door assembly at a 90 degree angle to the rack.
2. Unscrew the captive screw 3 on the hose-retention plate 2.
3. Lift the hose-retention plate 2 out of the door assembly.

To replace the hose-retention plate, complete the following steps:

1. Slide the middle flange 1 of the hose-retention plate 2 below the matching lip of the corresponding plate and wiggle the plate into place.
2. Fasten the captive screw 3 to attach the hose-retention plate 2 to the rack.

Attaching and detaching the hoses:

You might need to attach and detach the hoses to the Heat Exchanger. Use the procedure in this section to perform this task.

Attaching and detaching the supply hose:

You might need to attach and detach the supply hose. Use the procedure in this section to perform this task.

Remove the hose-retention plate before attaching or detaching the hoses. Refer to “Removing and replacing the hose-retention plate” on page 53.

Tip: It is easier to attach and detach the hose assemblies when there is no water pressure in the hoses.

Attaching and detaching the supply hose

Attach the water-supply hose to the female coupling (on the supply manifold) on the Heat Exchanger. To attach the supply hose, complete the following steps:

1. Align the male hose coupling 4 with the female supply-manifold coupling 3.

Note: If the coupling are misaligned, it will be difficult to connect the hose.

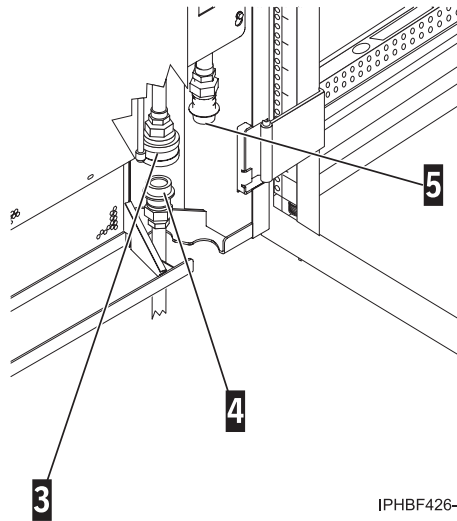

Figure 54. Attaching and detaching the supply hose.

2. Move the female collar upward.
3. Insert the male hose coupling 4. Exert upward pressure until the female collar 3 moves downward and locks in place with an audible click.

Note: After the couplings are engaged but before the collar has locked into place, you can release the collar and use both hands to push the hose upward to lock the couplings.

4. To detach the supply hose, move the female supply-manifold coupling collar 3 upward and pull the male hose coupling 4 from the female coupling.

Attaching and detaching the return hose:

You might need to attach and detach the return hose. Use the procedure in this section to perform this task.

Attach the water-return hose to the male coupling (on the return manifold) on the heat exchanger. To attach the return hose, complete the following steps.

Note: To make it easier to attach the return hose, turn off the water supply temporarily to remove water pressure. After attaching the return hose, turn on the water supply again.

Important: Exerting significant upward pressure on the door while connecting hoses can cause the door to release from the upper rack hinge. Take care not lift the door off the top hinge during these procedures. A blocking device, such as a piece of foam or metal, may be inserted into the door below the top hinge during these procedures to prevent the door from coming off its top hinge.

1. Align the female hose coupling 9 with the male return-manifold coupling 8.

Note: If you misalign the couplings, it will be difficult to connect the hose.

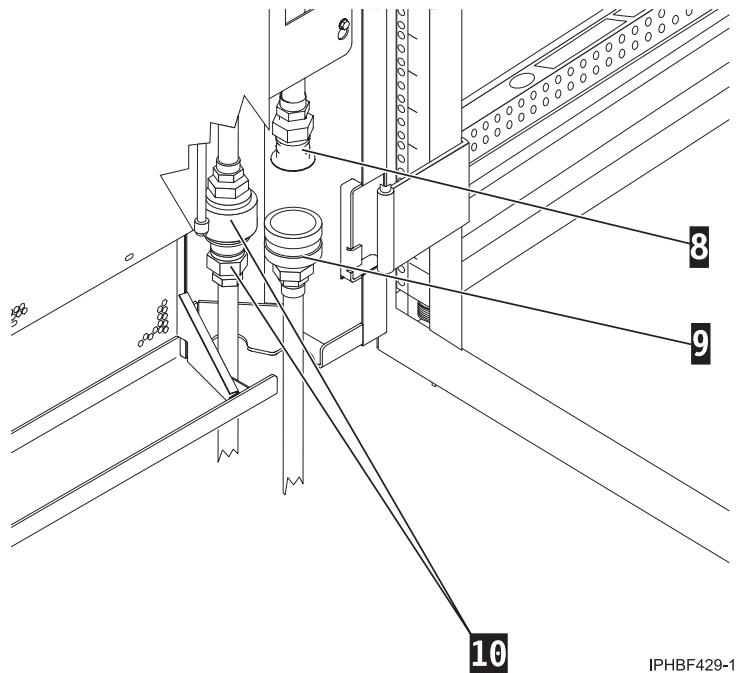

IPHBF429-1

Figure 55. Attaching and detaching the return hose.

2. Move the female collar downward 9 and raise the coupling to the male coupling 8.
3. Exert upward pressure until the female collar 9 moves upward and locks in place with an audible click. After the couplings are engaged but before the collar has locked into place, you can let go of the collar and use both hands to push the hose upward to lock the couplings.
4. To detach the return hose, move the female collar downward and pull the female hose coupling away from the male coupling.

Heat Exchanger maintenance schedule:

You might need to perform maintenance. Use the procedure in this section to perform this task.

Perform the following maintenance tasks at the indicated time intervals.

Table 1. Heat Exchanger maintenance schedule

Task	When to Perform
Inspect the fins of the Heat Exchanger for air blockage at the fins (from dust, dirt, debris, and so on)	Annually
Check the manifolds for temperature (make sure that the top of the manifolds are cool) and sounds of air in the system, to ensure that the Heat Exchanger is correctly filled.	One month after installation and then annually
Inspect the entire length of the supply hose and return hose for damage, age cracks, and kinks. Be sure to inspect at the door and outside of the rack.	Annually

Installing the rack security kit

You might need to install the rack security kit. Use the procedure in this section to perform this task.

To install a rack security kit (feature 6580) that consists of the security lock and security slide bars, complete the following procedure:

1. Read the "Rack Safety Notices" on page 1.
2. Verify the inventory in the rack security kit.

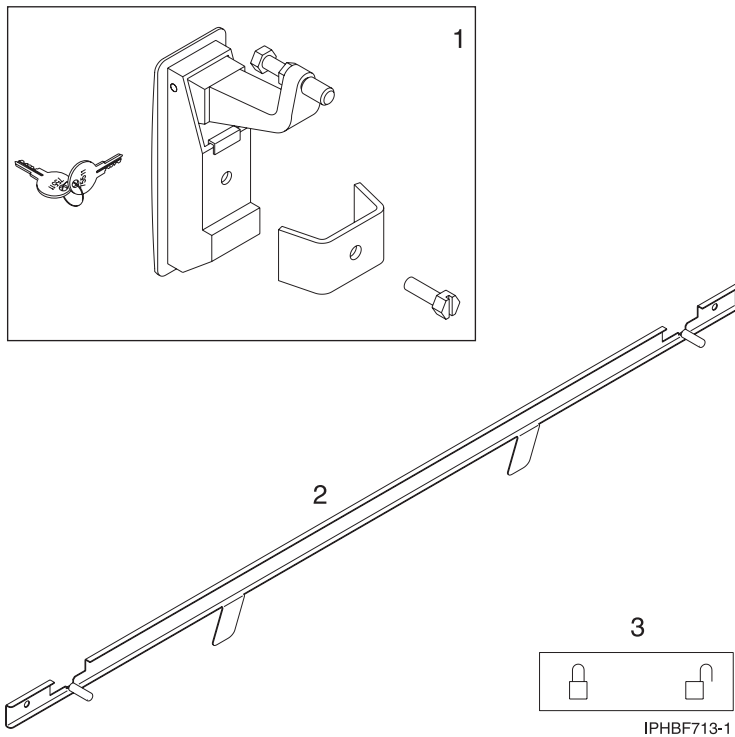

•

1 Two lock hardware kits. Each kit contains:

- Rack lock
- Bracket
- Screw
- Two keys

2 Two security slide bars

3 Two locked/unlocked stickers

Figure 56. Rack security kit inventory.

3. Remove the existing door latch.

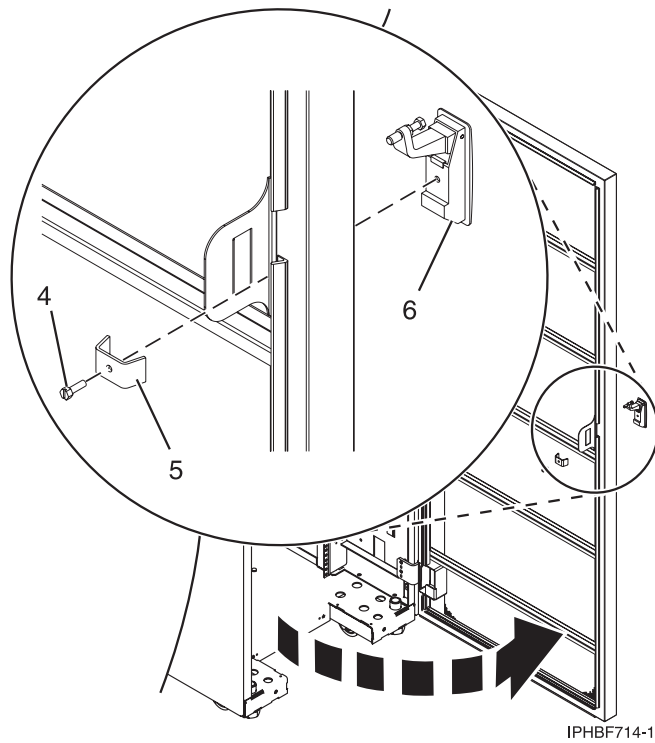

Figure 57. Removing the existing door latch.

- a. Open the front rack door.
- b. On the inside of the door, remove the screw 4 in Figure 57, that secures the lock to the rack door.
- c. Remove the bracket 5.
- d. From the outside of the door, remove the door latch 6.

Note: If the rack is equipped with the ruggedized kit, remove the jam nut and hex nut from the existing door latch and reinstall both nuts on the new door lock latch.

4. Install the locking latch.
 - a. Insert the keyed rack lock into the latch slot on the front of the door 6 in Figure 57.
 - b. Secure the lock by attaching the lock bracket 5 with the screw 4, on the inside of the door.
5. Repeat steps 3 on page 57 and 4 to install the second lock on the back rack door.
6. Install a security slide bar on the right side of the rack.

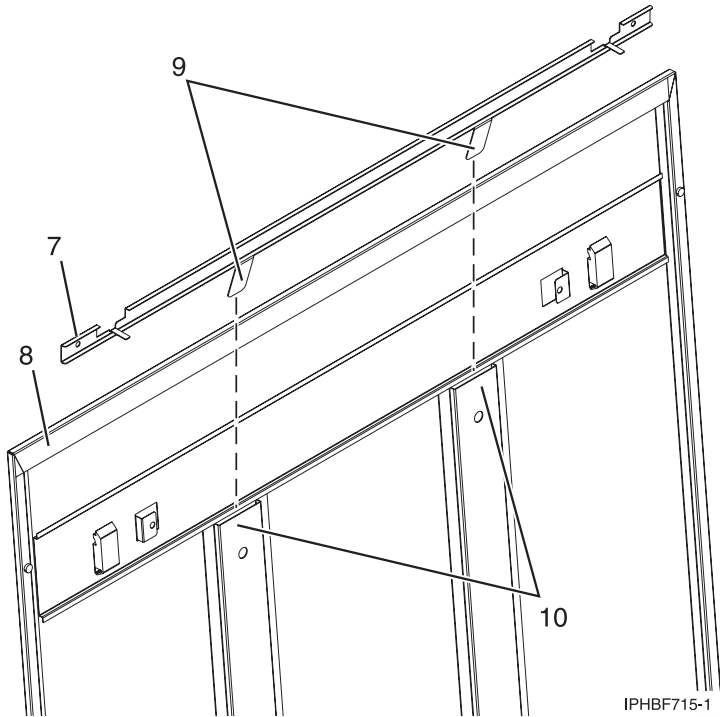

Figure 58. Installing a security slide bar.

Note: Each slide bar rail has two long tabs on the bottom of the rail. The slide bar rails are identical and can be installed on either the right or left side cover panel.

- a. Unlatch right-side cover panel and lean the panel back so that you can access the top of the panel.
- b. With the flat side of the slide bar rail 7 in Figure 58, facing the inside of the cover panel 8, insert the two tabs 9, on the slide bar rail into the two vertical support channels 10 on the side cover panel.

Note: When installed correctly, the slide rail should move front to back.

- c. Reinstall the side panel cover on to the rack.
- d. Lock the side panel covers by sliding the bars to the front of the rack.
- e. Place a locked/unlocked sticker on the inside of the cover panel so that when the slide bar is in the locked position, the tab is over the locked symbol, 11, as shown in Figure 59 on page 60 and over the unlocked symbol, 12, when the slide bar is unlocked.

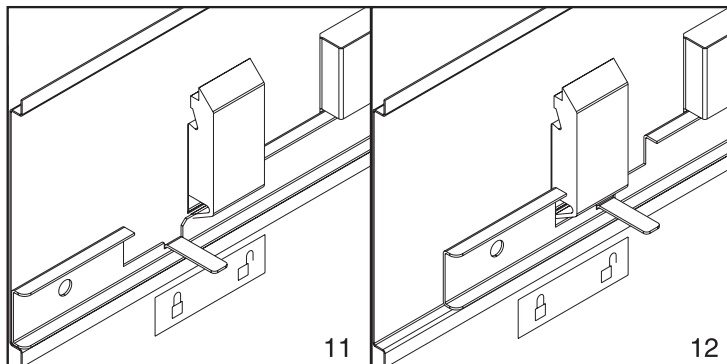

Figure 59. Placing the locked/unlocked sticker on the cover panel.

- f. Repeat the above procedure for the left side of the rack.

Ruggedized kit

You might need to remove or replace a part in the ruggedized kit. This section includes procedures so that you can perform these tasks.

The ruggedized kit, feature code 6080, should be ordered at the same time the rack is ordered. The ruggedized kit brackets are installed at the manufacturer.

Note: If you are installing a rack with the ruggedized kit and need to secure the rack to the floor, refer to “Installing the rack” on page 3.

The following illustration highlights the contents of the kit and the approximate location of each bracket and hinges in the event that you need to uninstall and reinstall a part.

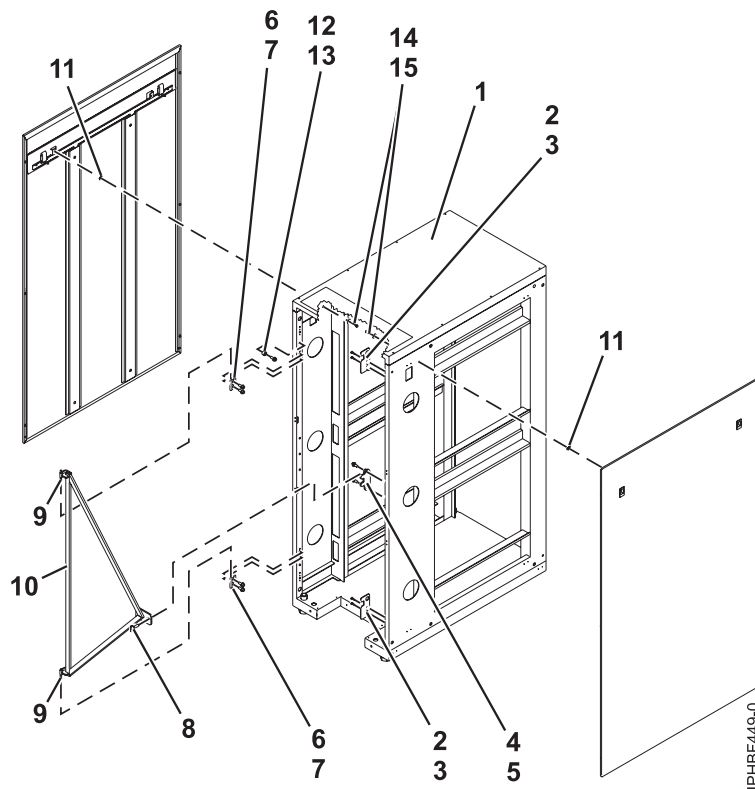

Figure 60. Ruggedized kit parts.

- | | |
|-----------------------|-----------------------------------|
| 1 Rack | 9 Brace hinges |
| 2 Spacer | 10 Brace |
| 3 Brace hinge | 11 Side-door securing screw mount |
| 4 Hinge pivot studs | 12 Spacer |
| 5 Brace latch bracket | 13 Screw |
| 6 Spacer | 14 Washer |
| 7 Screw | 15 Side door securing screw |
| 8 Brace thumbscrew | |

Releasing the ruggedized brace

You might need to release the ruggedized brace. Use the procedure in this section to perform this task.

To access the back of a system that is installed in a rack with a ruggedized kit, complete the following steps to release the ruggedized brace:

1. Remove the brace thumbscrew 8.

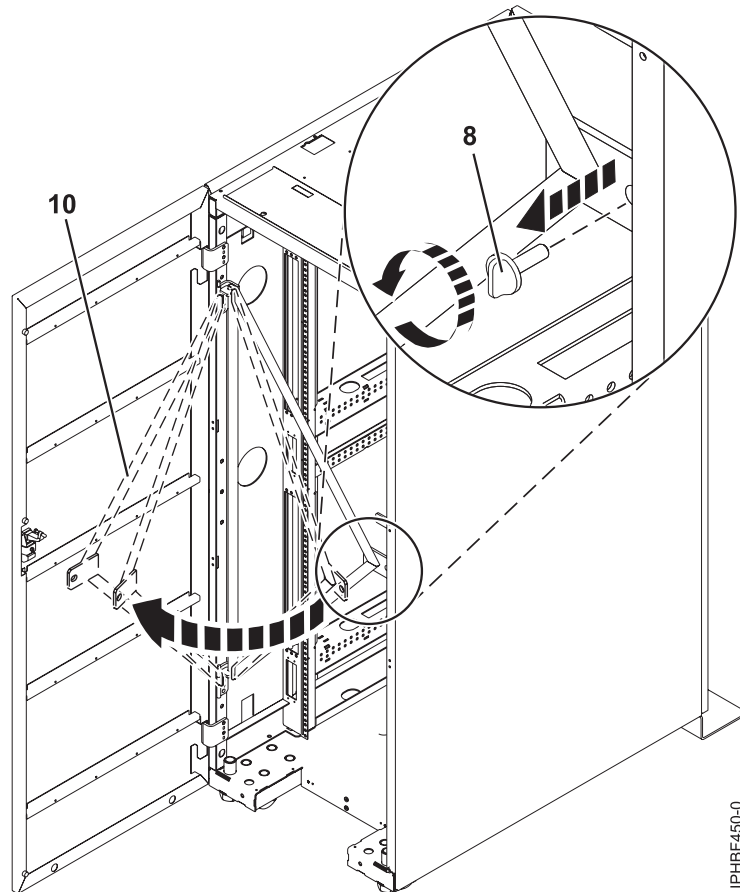

Figure 61. Releasing the brace to access systems.

2. Swing the brace 10 out of the rack.
3. Access the system and reinstall the brace.

Releasing the side panel with a ruggedized kit

You might need to release the side panel on the rack. Use the procedure in this section to perform this task.

The ruggedized kit contains securing screws that secure the side panels to the rack. To remove a securing screw, complete the following steps:

1. If necessary, open or remove the back rack door.
2. Locate the securing screw mount 11 for the side door that will be removed.

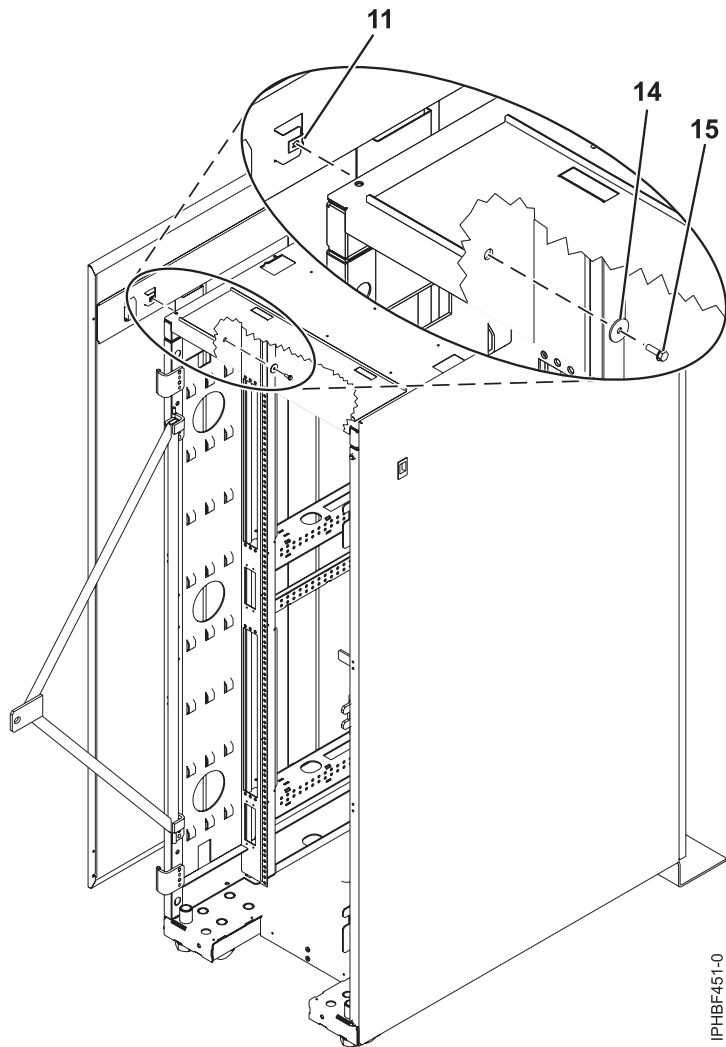

Figure 62. Removing the securing screws on the side panel.

3. Using a screwdriver, remove the securing screw **15** and washer **14** from the side panel. To remove the side panel, see “Removing and replacing 7014-T00, 7014-T42, 0551, or 0553 side panels” on page 30.

Connecting multiple racks with rack-to-rack attachment kit

You might need to connect multiple racks together. Use the procedure in this section to perform this task.

This topic describes how to connect multiple racks to each other using a rack-to-rack attachment kit. To do this, you will need the rack-to-rack attachment kit (feature 7840):

1. Read the “Rack Safety Notices” on page 1.
2. Remove the side panels from each rack, if they are installed. Remove side panels only from the sides that will be attached to each other. To do this:
 - a. Lift the two panel-release tabs up.
 - b. Pull the panel up and away from the rack chassis. This motion will release the panel from the two lower J brackets.
 - c. Store the side panels.
3. Remove the two Z brackets and the two J brackets. These brackets are used to hang the side panels.
4. Install the first two standoffs in the upper-left and lower-right corners of the first rack as shown in Figure 63 on page 63.

5. Install the second two standoffs in the upper-left and lower-right corners of the second rack as shown in Figure 63.
6. Attach the long foam as shown in Figure 63. For a model T42 rack, join the short foam to the end of the long foam, and adhere it to the frame length of the rack.
7. Position the racks together.
8. Align the standoff holes. You might need to adjust the leveling feet to do this.
9. Install a screw and washer into all four positions, but do not tighten.

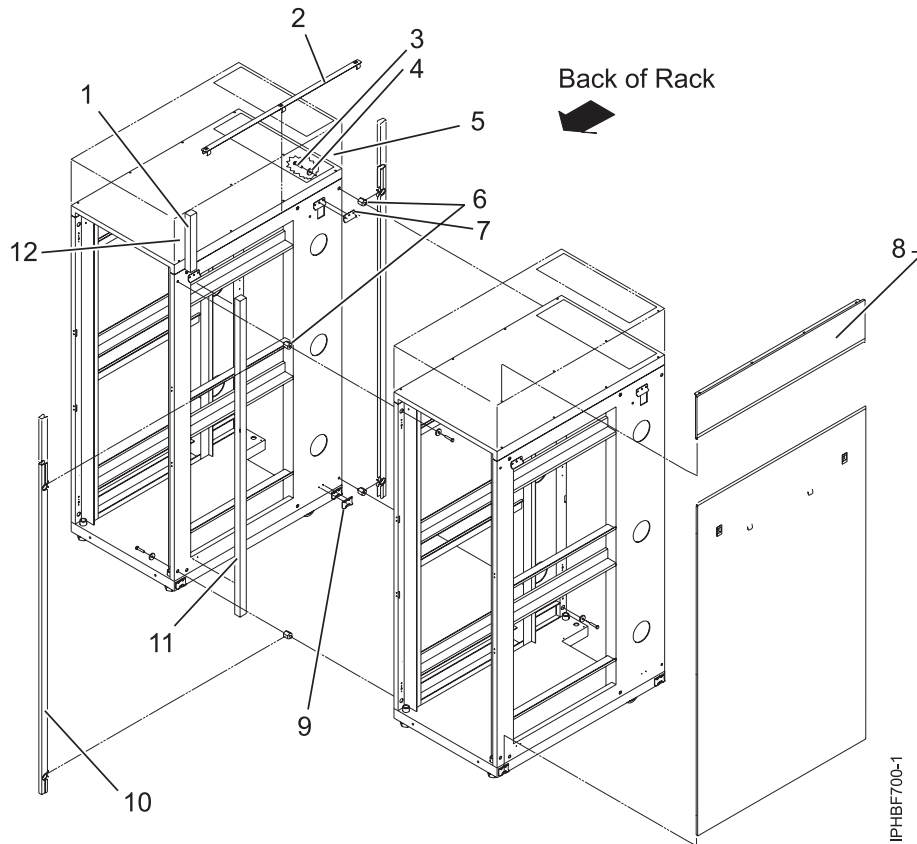

Figure 63. Removing the side panels, Z and J brackets, and installing standoffs and long foam to connect multiple racks.

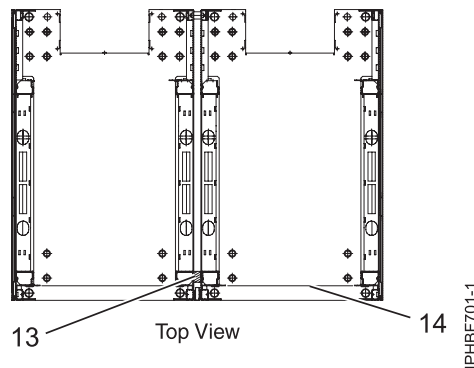

Figure 64. Location of foam strips (top view).

10. After all racks are bolted together, level the racks.
11. Tighten all four screws.

12. Snap on the trim pieces that go between the front and back racks.
13. Snap on the trim piece that goes on top and between the racks.
14. Install rack filler panels to cover the open areas at the front of the racks. All the gaps in the front of the rack must also be sealed, including the gaps between equipment. This step ensures that proper airflow within the rack is maintained.
15. Connect the cables that go between the racks.
16. If you are installing tip plates, go to step 5 in Install a rack.

Rack status beacon

You might need to install a rack status beacon. This section includes procedures so that you can perform these tasks.

This is a customer task. You can perform this task yourself, or contact a service provider to perform the task for you. The service provider might charge you for this service.

These procedures assume that the system units have been installed into the rack and have been connected to the power supply. If the system units have not been installed, refer to the installation instructions for your system unit.

The rack status beacon is designed to be placed on top of a rack and cabled to multiple system units inside the rack. The server firmware will illuminate the rack status beacon in response to any detected problems in the status. This helps you locate the problem more quickly.

Installing the rack status beacon

You might need to install the rack status beacon. Use the procedure in this section to perform this task.

To install the rack status beacon, you need the following:

- Rack status beacon assembly.
- Two or more rack status beacon cables. You need one cable to connect the beacon to the junction box and one for each system unit that you want to connect to the beacon.
- One or two power cords.
- One or more junction boxes for the rack status beacon.
- One or more junction box cables.

To install the rack status beacon, follow these steps:

1. Place the rack status beacon, **A**, on top of the rack so that the light is pointing to the front of the rack.

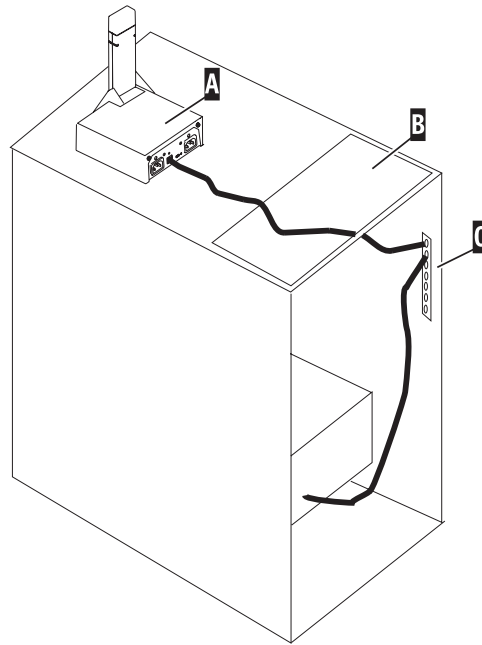

- A** Rack Beacon
- B** Cable Access Cover
- C** Junction Box

IPHBF702-0

Figure 65. Connecting the rack status beacon to the system unit through the junction box.

2. Plug one end of the rack status beacon cable 1 into the port on the back of the rack status beacon assembly.

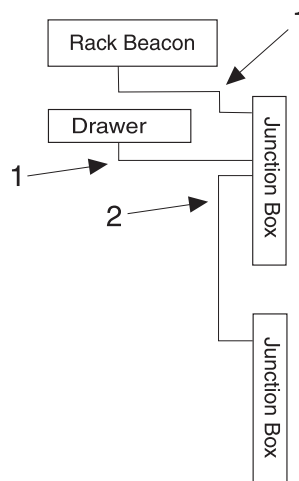

IPHBF703-0

Figure 66. Connecting the rack status beacon and system unit to the junction box.

3. Thread the rack status beacon cable through the rack's cable access cover, **B**.
4. Plug the other end of the rack status beacon cable into the output port on the junction box, **C**.
5. To connect the junction box to the system unit, plug one end of a rack status beacon cable, **1**, into an input port on the junction box.

6. Plug the other end of the second rack status beacon cable into the beacon port on the system unit. This port is labeled with a beacon symbol.

Note: On some system units, the orientation of the port is rotated.

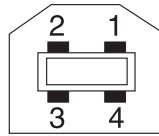

IPHBF704-0

Figure 67. Rack status beacon port.

7. To add additional system units to this rack status beacon, repeat steps 4 and 5 for each additional system unit. You can connect multiple junction boxes to add additional system units. Refer to Connect multiple junction boxes.
8. Plug the power cords into the rack status beacon assembly. Only one power cord is required, but you can use two power cords for backup.
9. Plug the other end of the power cords into the rack power supply.

If you install the rack status beacon during initial server setup, the initial program load (IPL) will read the rack identification information. If you install the rack status beacon on system units that are running, you will need to start the system again.

Connecting multiple junction boxes

You might need to connect multiple junction boxes. This section includes procedures so that you can perform these tasks.

You can connect multiple junction boxes so that additional system units can be added to the rack status beacon.

To connect multiple junction boxes, you need the following additional equipment:

- One or more rack status beacon junction boxes.
 - One or more junction box cables. You need a junction box cable for each junction box that you want to add.
1. Plug the one end of the junction box cable, **2**, into an input port on the first junction box.

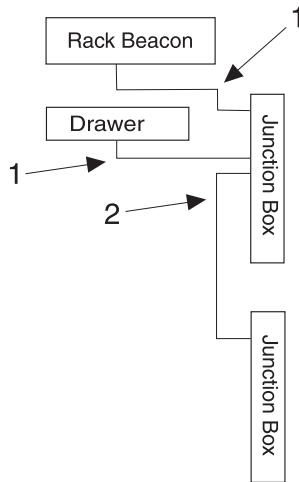

IPHBF703-0

Figure 68. Connect the rack status beacon and system unit to the junction box.

2. Plug a junction box cable into the output port of the additional junction box.
3. Connect additional system units to the additional junction box as described in “Installing the rack status beacon” on page 64.
4. Repeat steps 1–3 for each additional junction box.

Installing or removing a rack-mounted system-unit latch bracket

You might need to install or remove a latch bracket. Use the procedure in this section to perform this task.

These procedures describe how to install or remove the rack-mounted system-unit latch bracket. You can perform this task yourself, or contact a service provider to perform the task for you. The service provider might charge you for this service.

To install or remove a latch bracket, complete the following steps:

Note: The illustrations in these procedures may differ from your machine type and model.

1. Read the “Rack Safety Notices” on page 1.
2. Open the front rack door.
3. To install the latch brackets, align the latch bracket posts **C** with the holes in the system unit. Push the latch bracket **A** or **B** into place on the side of the system unit.

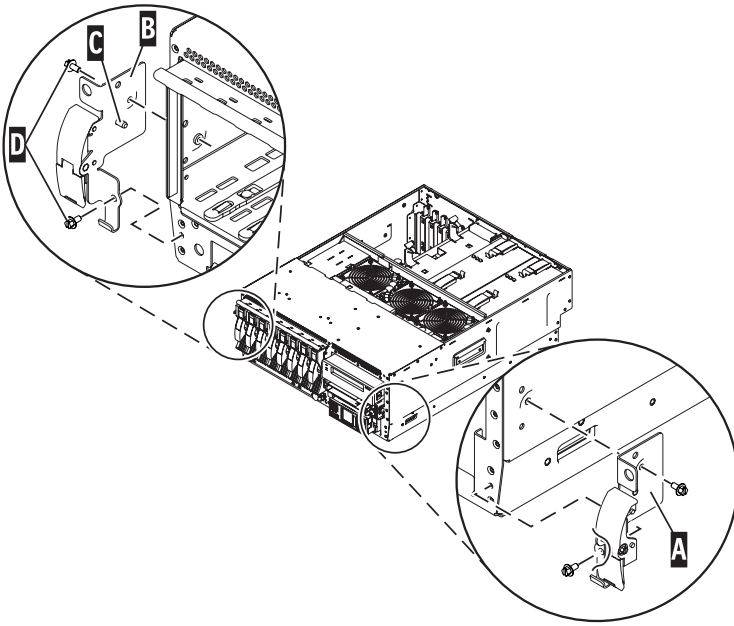

IPHBF508-0

Figure 69. Reinstalling the latch brackets.

4. Secure the latch bracket with two retaining screws **D**, one on the front, and one on the side of the latch bracket.
5. Replace the front cover. See the instructions for your model..
6. Close the front rack door.

To remove a latch bracket, complete the following steps:

1. Remove the cover from the front of the system. See the instructions for your model.
2. Place the system in the service position. See the appropriate model's instructions.
3. Remove the retaining screws **D** located on the front and side of the latch bracket **A** or **B**.

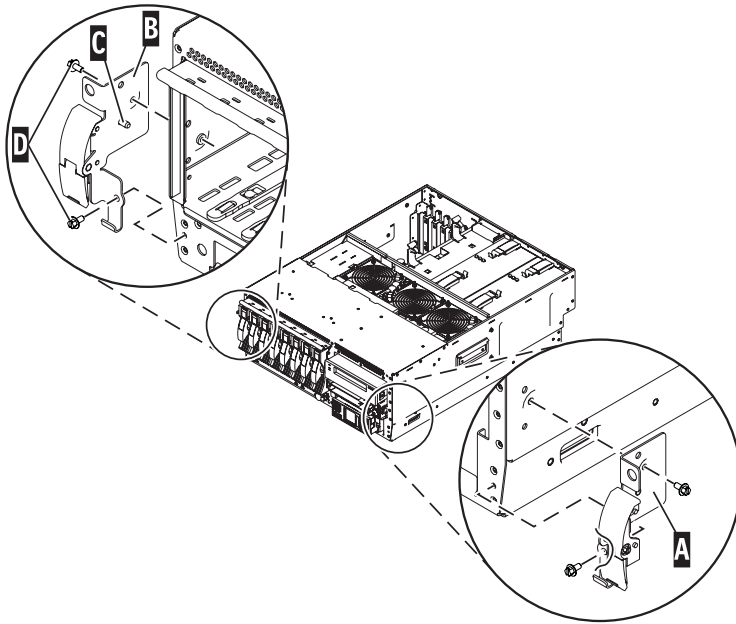

IPHBF508-0

Figure 70. Removing the retaining screws.

4. Remove the latch bracket from the system unit.

Power distribution unit plus (PDU+)

The power distribution unit plus (PDU+) can be installed in the 7014-S25, 7014-T00, and 7014-T42 racks, and allows you to monitor the individual power loads of the devices that are plugged into it.

Installing the PDU+ in the side of a rack

Learn how to install the power distribution unit plus (PDU+) in the side of a rack.

Tip: Removing the rack doors and side panels might make installation easier.

Important: You must use clip nuts to install the mounting brackets. Clip nuts are provided with the PDU+ and install on the rack-mounting flanges.

To install the PDU+ in the 1U mounting space in the side of a rack, complete the following steps

1. Read the “Rack Safety Notices” on page 1.
2. Align the vertical-mounting brackets to the front of the PDU+. Make sure that you attach the brackets so that the power outlets face the rear of the rack.

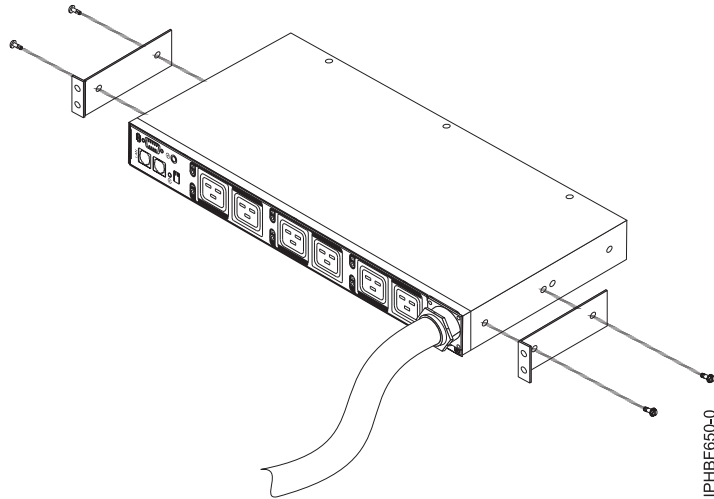

Figure 71. Aligning the vertical-mounting brackets to the front of the PDU+.

3. Attach the brackets to the PDU+ with two M3x5 screws per bracket. Use the screws that were provided with the PDU+.
4. Align the PDU+ with the opening in the side of the rack. Then, while holding the PDU+ in place, attach the brackets to the rack-mounting flanges with four clip nuts and four M5 screws that were provided with the PDU+.

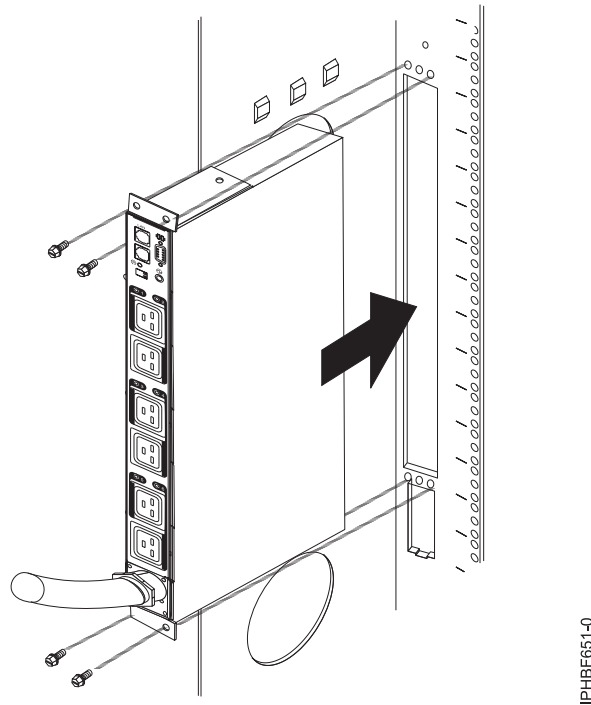

Figure 72. Aligning the PDU+ with the opening in the side of the rack.

Attention: You must disconnect the main input power before connecting or disconnecting the input power cord from the PDU+.

5. If the PDU+ was provided with a detached power cord, connect the power cord now. Align the connector on the power cord that was provided with the PDU+ with the connector on the front of the

PDU+, turning as necessary for key alignment. Then, turn the twist-lock on the connector clockwise until it locks into place.

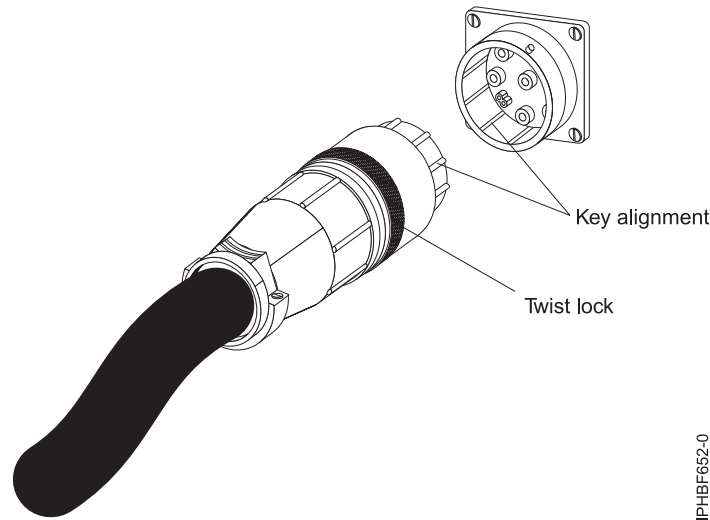

Figure 73. Aligning the connector on the power cord with the PDU+.

6. Route the power cord from the PDU+ toward the rack side braces. Then, route the power cord along a side brace toward the back of the rack and secure the power cord with the cable straps that are provided with the PDU+.
7. Route the power cord toward a dedicated power source. Use the provided cable straps to secure the power cord along the way. Use the openings in the rack, if the power cord must exit the rack to connect to a power source.

Attention: To prevent damage to a power device and other connected devices, always connect the power device to an authorized power source for that device.

8. Connect the power cord to a properly wired and grounded dedicated power source. Then, you can connect servers or rack PDUs in the rack to the power outlets on the PDU+.
9. Route all of the other power cables neatly and secure the power cables with cable straps.

To learn how to set up power monitoring using the PDU+, see “Setting up power monitoring using the PDU+” on page 75.

Installing the PDU+ horizontally in a rack:

You might need to install the PDU horizontally, use the instructions in this section to complete this task.

Tip: Removing the rack doors and side panels might make installation easier.

Important: Use cage nuts for rack cabinets with square holes, and use clip nuts for rack cabinets with round holes. If your rack cabinet requires cage nuts, use a cage-nut-insertion tool or a flat-blade screwdriver to install them..

To install the PDU+ in the rack, complete the following steps

1. Read the “Rack Safety Notices” on page 1.
2. Align the vertical-mounting brackets to the front of the PDU+. Make sure that you attach the brackets so that the power outlets face the rear of the rack.

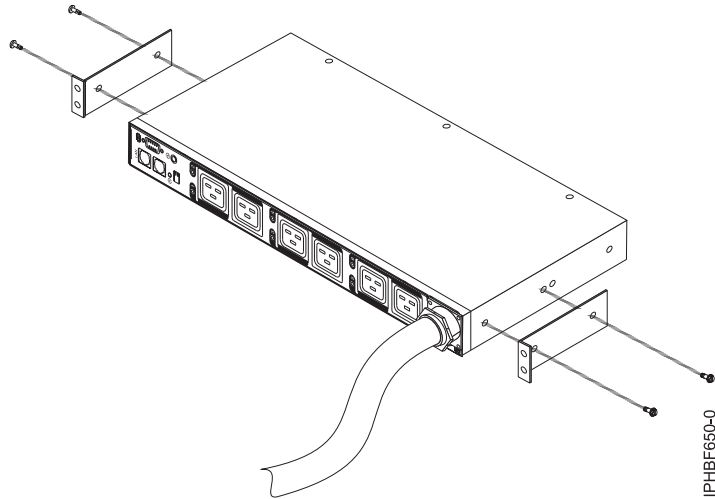
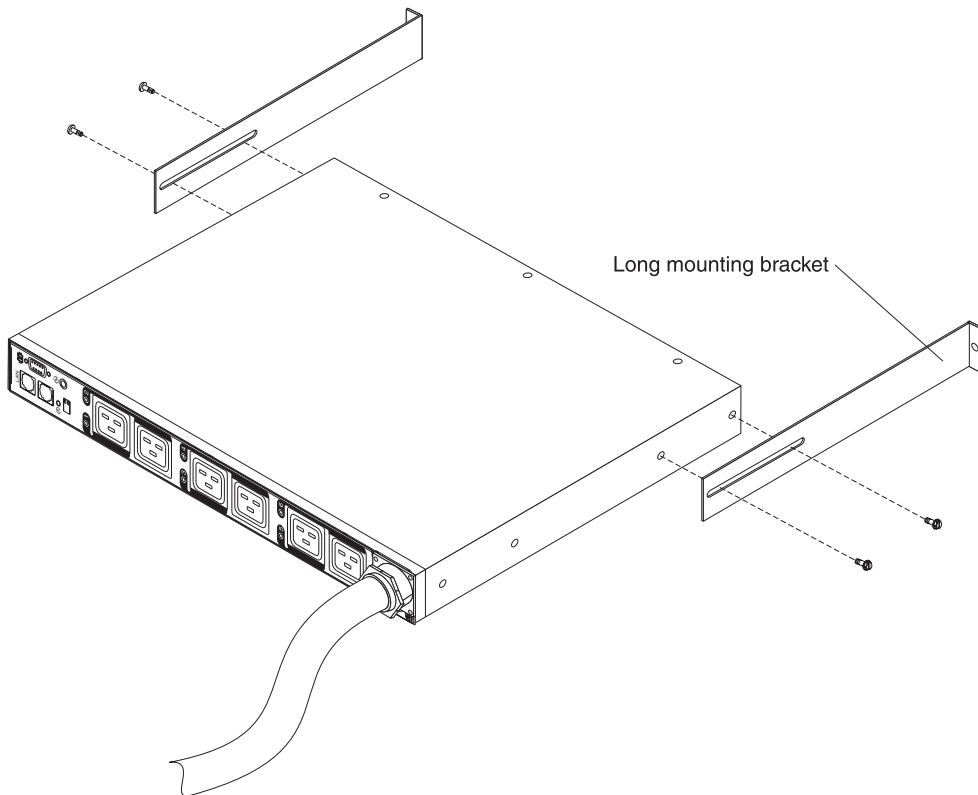

Figure 74. Aligning the vertical-mounting brackets to the front of the PDU+.

3. Align the long mounting-brackets with the holes in the rear of the PDU+ and attach the brackets to the PDU+ with two M3 pan-head screws with captive lock washers per bracket. Use the screws that come with the rack-mounting kit.



4. Hold the PDU+ at a slight angle and carefully insert it into the 1-U mounting space in the rack cabinet. Pushing in slightly on both of the long mounting-brackets helps clear the brackets from the rack flanges.

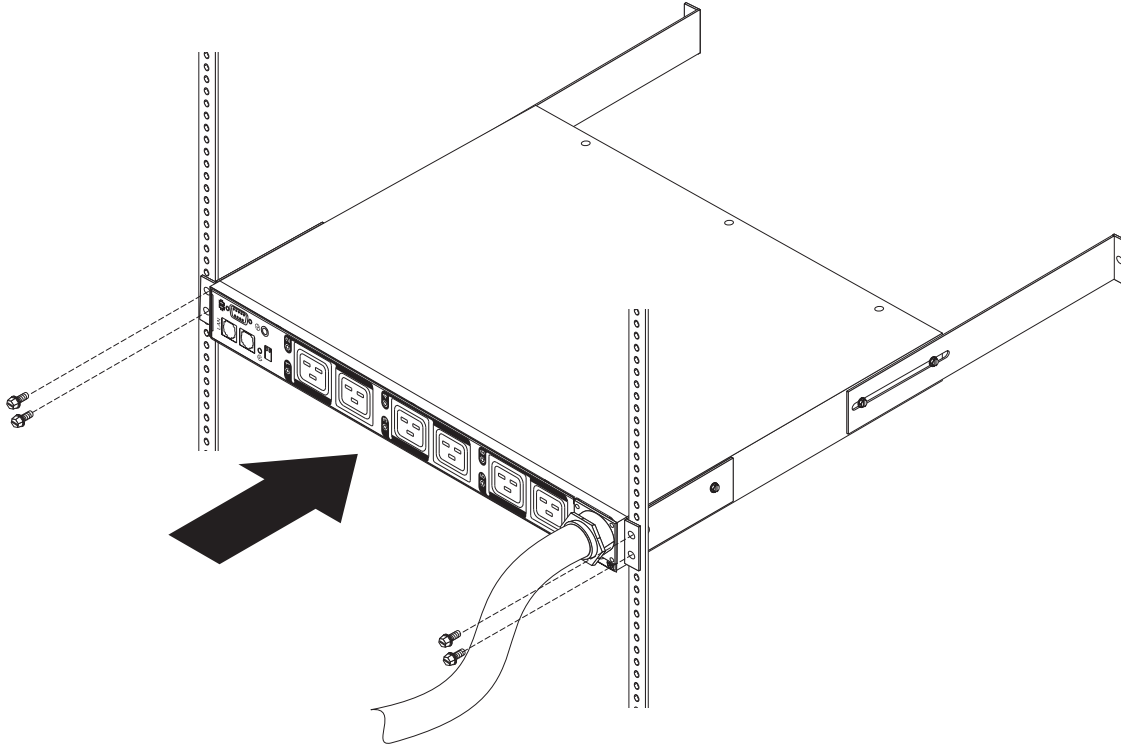
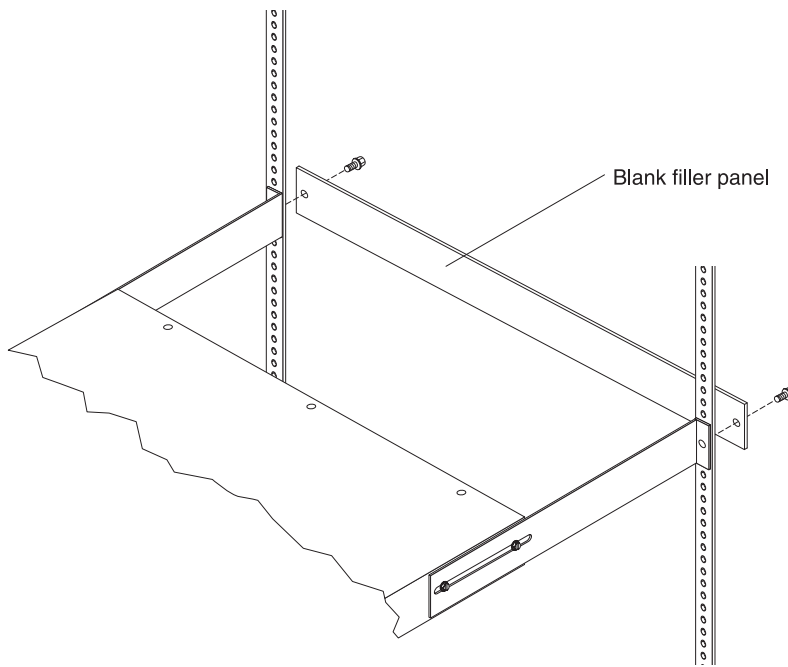

Figure 75. Aligning the PDU+ with the opening in the rack.

Attention: You must disconnect the main input power before connecting or disconnecting the input power cord from the PDU+.

5. Secure the end of the PDU+ that has the short mounting-brackets to the rack cabinet first. Make sure that the short mounting-brackets are aligned with the outside of the rack flanges. Attach the brackets to the rack flanges with two M6 screws and two cage nuts or clip nuts per bracket. Use the cage nuts or clip nuts and the screws that come with the rack-mounting kit.
6. Secure the long mounting-brackets and the 1-U blank filler panel to the rack cabinet by doing the following:



- a. Adjust the long mounting-brackets to fit the depth of the rack cabinet.
 - b. Make sure that the long mounting-brackets are aligned with the inside of the rack flanges.
 - c. Align the blank filler panel on the outside of the rack flanges.
 - d. Attach the filler panel to the rack flanges and then to the long mounting-bracket with one M6 screw per bracket.
 - e. Tighten the M3 pan-head screws that secure the long mounting-brackets to the PDU.
7. Secure the end of the PDU+ that has the short mounting-brackets to the rack cabinet first. Make sure that the short mounting-brackets are aligned with the outside of the rack flanges. Attach the brackets to the rack flanges with two M6 screws and two cage nuts or clip nuts per bracket. Use the cage nuts or clip nuts and the screws that come with the rack-mounting kit.
 8. If the PDU+ was provided with a detached power cord, connect the power cord now. Align the connector on the power cord that was provided with the PDU+ with the connector on the front of the PDU+, turning as necessary for key alignment. Then, turn the twist-lock on the connector clockwise until it locks into place.

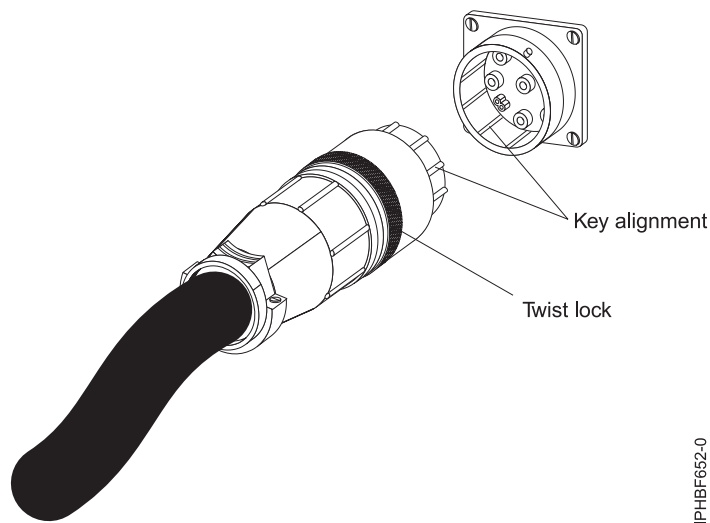

Figure 76. Aligning the connector on the power cord with the PDU+.

9. Route the power cord from the PDU+ toward the rack side braces. Then, route the power cord along a side brace toward the back of the rack and secure the power cord with the cable straps that are provided with the PDU+.
10. Route the power cord toward a dedicated power source. Use the provided cable straps to secure the power cord along the way. Use the openings in the rack, if the power cord must exit the rack to connect to a power source.

Attention: To prevent damage to a power device and other connected devices, always connect the power device to an authorized power source for that device.
11. Connect the power cord to a properly wired and grounded dedicated power source. Then, you can connect servers or rack PDUs in the rack to the power outlets on the PDU+.
12. Route all of the other power cables neatly and secure the power cables with cable straps.

To learn how to set up power monitoring using the PDU+, see “Setting up power monitoring using the PDU+.”

Setting up power monitoring using the PDU+

You can monitor the power status for any device that is connected to the power distribution unit plus (PDU+), either manually or remotely, through the PDU+ Web interface. You can use the IBM DPI[®] Configuration Utility to initially set up the PDU+ and to configure PDU+ settings such as network parameters, access control table, and trap receivers table.

Note: All of the Configuration Utility configuration options are available through the Web interface after the PDU+ is set up on the local network.

Using the IBM DPI Configuration Utility:

Learn how to use the IBM DPI Configuration Utility to configure the power distribution unit plus (PDU+) settings, such as the IP address, network parameters, access control table, and trap receivers table.

Connecting the console:

You can configure the PDU+ using a workstation or notebook computer that is connected to the PDU+. Connect the DB9-to-RJ-45 cable that is shipped with the PDU+ to the RJ-45 console connector on the PDU+, and to a RS-232 serial (COM) connector on a workstation or notebook computer.

Using HyperTerminal:

HyperTerminal is a terminal program in a Microsoft® Windows® operating system that enables you to configure or control a device using command line parameters. You can configure the PDU+ parameters and its outlets using numeric commands from a keyboard. You can also use Telnet or any other terminal program to configure the PDU+ after the IP address is set.

To start HyperTerminal and communicate with the PDU+, complete the following steps:

1. Click **Start** → **Programs** → **Accessories** → **Communications** → **HyperTerminal**. The Connection Description window is displayed.
2. Type the name for the connection in the **Name** field and select an icon for the connection.
3. Click **OK**. The Connect To window is displayed.
4. In the **Connect using** field, select the COM port that is connected to the PDU+.
5. Click **OK**. The Properties window is displayed.
6. Click **Restore Defaults** to use the default settings. Make sure that the **Bits per second** field is 9600 and that the **Flow control** field is None.
7. Click **OK**.
8. Press any key. The Configuration Utility main menu is displayed.
9. Type the default password, passw0rd (all lowercase letters with a zero, not O), and press Enter.
10. Enter the menu option that you want. For descriptions of the options, see “Configuration Utility menu options.”

Configuration Utility menu options:

The following options are on the Configuration Utility main menu:

IBM DPI Settings

When you select IBM DPI Settings, the IBM DPI Configuration Utility window is displayed with the following options:

Set the IP Address, Gateway Address and MIB System Group

View and change the IP address, date, time, and MIB system information.

Set IBM DPI Control Group

Set the administrator user name, password, and access protocols.

Set Write Access Managers

Set up a list of users who can access and control the PDU+.

Set Trap Receivers

Configure remote network management system (NMS) servers to receive traps.

Set Date and Time

Adjust the date and time information for the PDU+.

Set Superuser Name and Password

Set the user name and password of the administrator who will use a Web browser to configure the PDU+.

E-mail Notification

Set up a list of users who will be alerted with event messages if an unusual event is triggered on the PDU+ system.

Set Multi-Users

Configure other user and password logins and the read and write access levels.

Set IBM DPI Information

Configure the PDU+ logging interval, refresh rate, and custom name fields for the load groups.

Settings and Event Log Summary

View all PDU+ configuration settings.

Reset Configuration to Default

Reset all system settings to their factory default values.

Restart HD-PDU

Restart the PDU+.

Setting the IP address:

Important: You must set the IP address before you can use the Web interface or access the PDU+ in an IP network (LAN/WAN). Contact your system administrator if you do not know the IP address.

To set the IP address, complete the following steps:

1. In the Configuration Utility main menu, enter the menu option for **IBM DPI Settings**.
2. Enter the menu option for **Set the IP Address, Gateway Address and MIB System Group**.

Using the Web interface:

Learn how to use the Web interface to configure and monitor the power distribution unit plus (PDU+) remotely. The PDU+ provides a graphical user interface that you can view from a Web browser. Using a Web browser, you can access and monitor the PDU+ power outlets and output devices remotely from a workstation or notebook computer.

Starting the Web interface:

To start the Web interface, complete the following steps:

1. Start a Web browser from a workstation or notebook computer, and enter the IP address of the PDU+ in the **address** field. The **Connect to** window is displayed.

Note: For more information about setting the IP address of the system, see "Setting the IP address."

2. In the **User name** field, type USERID (all uppercase letters).
3. In the **Password** field, type passw0rd (all lowercase letters with a zero, not O).
4. Click **OK**. The main status page is displayed.

The main status page displays a graphical representation of the PDU+ power outlets and input status:

- The left pane displays the menus and submenus for the PDU+. Click a menu to display the menu options, expand the menu items, and modify the menu options as required.
- The graphic displayed in the right pane shows the status of the outlets, input voltage, output voltage, frequency, current and power, watt-hour consumption, and cumulative kilowatt hour power consumption. If you connect an optional environmental monitored probe, the temperature and humidity environment conditions are displayed.

Each menu page provides online help to assist you with configuring the PDU+. Click the **Help** icon at the top of each page to view the help.

Modifying the basic settings:

Use the System menu to configure the PDU+ system parameters such as the superuser name, password, IP address, date, and time.

Changing the superuser name and password:

You can set the user name and password of the administrator who will use a Web browser to configure the PDU+ on the Configuration Utility page.

To change the superuser name and password, complete the following steps:

1. From the main status page, in the left navigation pane, click **System**.
2. Click **Configuration** to view and modify the system configuration and superuser user name and password.

Identifying the PDU+ and Web/SNMP card:

You can view the PDU+ and Web/SNMP card information on the Identification of Power Management page.

To view the power management information of the PDU+ and Web/SNMP card, complete the following steps:

1. From the main status page, in the left navigation pane, click **System**.
2. Click **Identification** to view the PDU+ and Web/SNMP card information.

Adding users:

You can add users who can access and control the PDU+ on the Multi-User Configuration page.

To create a list of users who can access and control the PDU+, complete the following steps:

1. From the main status page, in the left navigation pane, click **System**.
2. Click **Multi-User** to add users who can only view the PDU+ status or users who can change the PDU+ settings.

Changing the date and time:

You can change the date and time of the PDU+ on the Date and Time page.

Important: Changing the PDU+ date and time affects other system settings such as e-mail, traps, and logs.

To change the date and time, complete the following steps:

1. From the main status page, in the left navigation pane, click **System**.
2. Click **Date and Time** to view and modify the system date and time. You can set the date and time manually, synchronize it with the computer time, or synchronize it with an NTP server.

Changing event alerts:

You can change event alerts on the SNMP Trap Receivers page.

To configure the PDU+ to send e-mail or SNMP trap alerts to specified users when specific events occur, complete the following steps:

1. From the main status page, in the left navigation pane, click **System**.
2. Click **Trap Receivers** to create a list of users or workstations who will be alerted with an SNMP trap message. You can specify the IP addresses of up to eight trap receivers, the community information, type of trap, severity of trap, and description of the events that cause the traps.
3. Click **Email Notification** under **System** to create a list of up to four users who will be alerted with an e-mail. Use this menu to specify the mail server, user account, DNS, and other information necessary to set up a mail server for sending mail alerts. Use the Email Receivers Table to add the e-mail addresses.

Changing the network information:

Use the Network menu to change the network information for the PDU+, for example, the IP address.

Changing the network configuration:

You can view or change the network configuration on the Network Configuration page.

To view or change the network configuration of the PDU+, complete the following steps:

1. From the main status page, in the left navigation pane, click **Network**.
2. Click **Configuration** to set the PDU+ IP address, gateway address, subnet mask, and Domain Name System (DNS) address.
3. Click **Control** to configure TCP/IP settings.
4. Click **Access Control** to set access control to prevent unauthorized users from accessing the PDU+.

History and event log summaries:

The Logs menu provides a detailed description of all events and a record of the PDU+ status. System administrators can use this page to analyze problems with network equipment.

Viewing the history log:

You can view the complete history of the PDU+ inputs and outputs on the History Log page.

To view the history of the PDU+, complete the following steps:

1. From the main status page, in the left navigation pane, click **Logs**.
2. Click **History**. Each event log file shows the time, date, and description of all the events occurring on the PDU+.

Viewing the event log:

You can view the complete record of the PDU+ events on the Event Log page.

To view the complete record of the PDU+ events, complete the following steps:

1. From the main status page, in the left navigation pane, click **Logs**.
2. Click **Events**. Each log file shows a record of the input power and output power of each outlet.

Installing a system or expansion unit into a rack

You might need to install a system or expansion unit into a rack. This section includes procedures so that you can perform these tasks.

The following procedures describe how to install system units or expansion units into a rack. You can perform this task or contact a service provider to perform the task for you. You might be charged a fee by the service provider for this service.

Installing the model 505 or 9115-505 into a rack

You might need to install the system into a rack. Use the procedure in this section to perform this task.

This topic describes how to install the system into a rack. This is a customer task. You can perform this task yourself, or contact a service provider to perform the task for you. You might be charged a fee by the service provider for this service.

This procedure assumes that you are installing the system into an existing rack. If the rack is not installed, go to the instructions for installing a rack and then return to this procedure for instructions on installing the system unit into the rack. See *Install a rack*.

To install the system into a rack, complete the following steps:

Attention: Installing the rails in the rack is a complex procedure. To install the rails correctly, you must perform each task in the following order.

1. Read the “Rack Safety Notices” on page 1.
2. Complete a parts inventory. See *Complete a parts inventory*.
3. Locate the rack-mounting hardware kit and the system rail assemblies that were included with your system unit.

There are two types of rail kits for this system. A sliding-rail kit **A-G** and a fixed rail kit **H-K**.

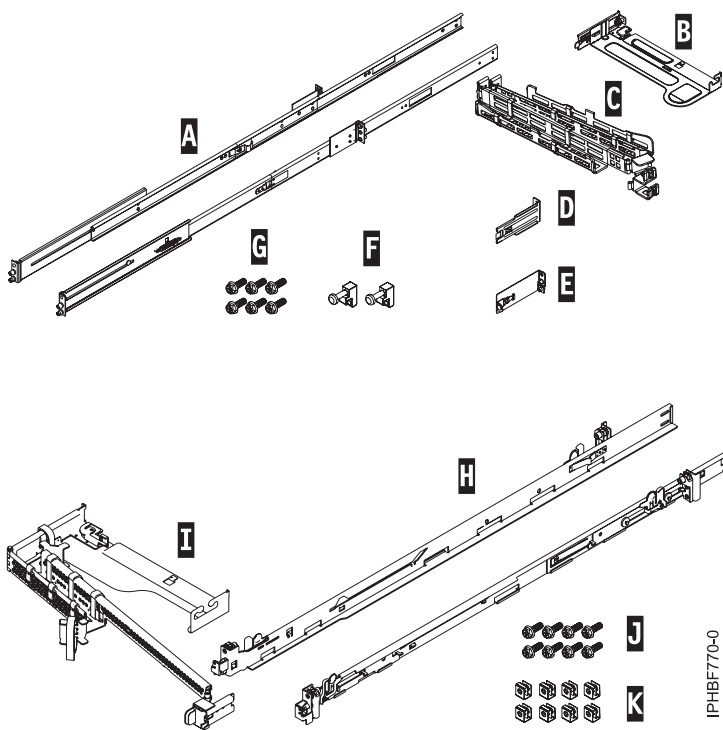

Figure 77. Rail Kits

Table 2. Rail kit parts

Sliding-rail kit parts	Fixed-rail kit parts
A- slide rails	H- fixed rails
B- cable-management arm mounting plate	I- cable-management arm
C- cable-management arm	J- screws
D- cable-management bracket	K- cage nuts
E- cable-management support bracket and security tab	
F- latch strikes	
G- screws	

Use the next topic to determine where to place your system unit in the rack.

Important: This system unit is one EIA unit high; you will need this information to complete the next section.

Determining the location

You might need to determine where to install the system in the rack. This section includes procedures so that you can perform these tasks.

Before installing the system unit or expansion unit into a rack, complete the following steps:

1. Read the “Rack Safety Notices” on page 1.
2. Plan where you will place the units. Place the larger and heavier units in the lower part of the rack.
3. If the rack contains filler panels, remove the filler panels to allow access to the inside of the rack enclosure where you plan to place the unit.

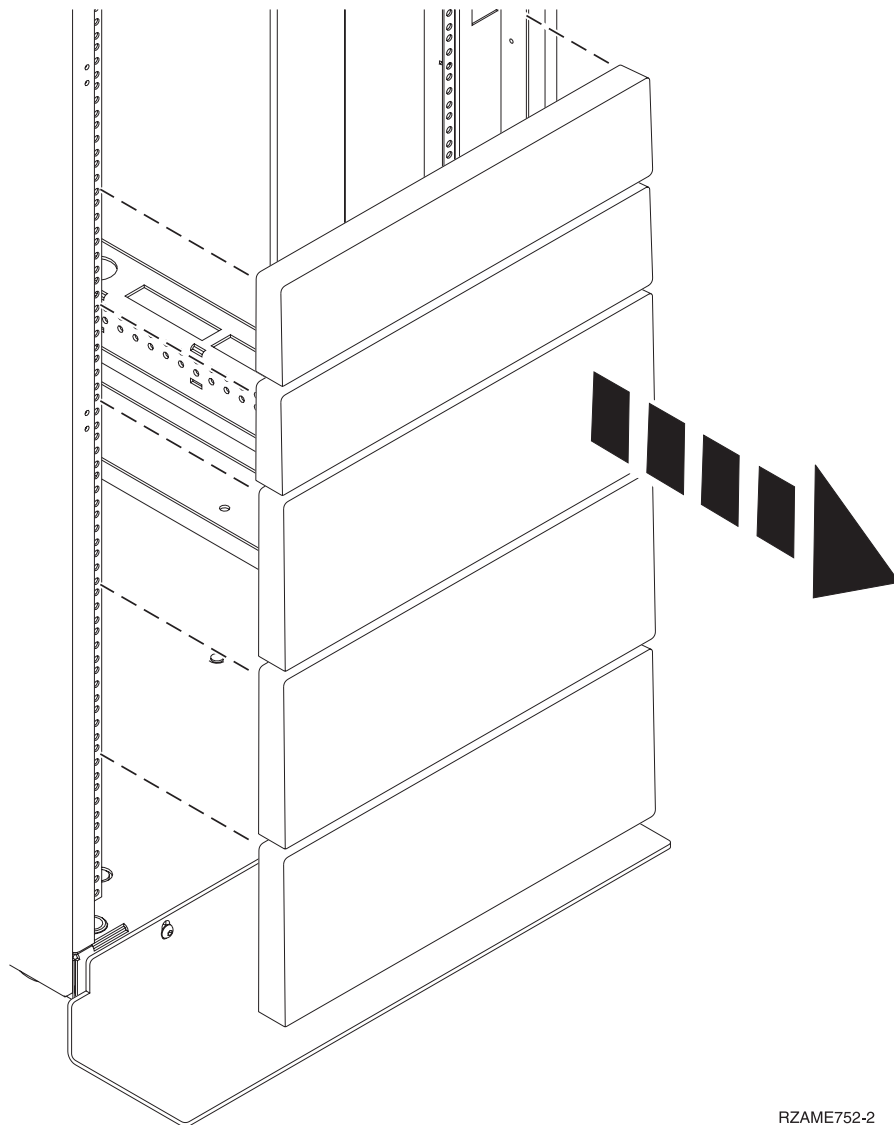

RZAME752-2

Figure 78. Removing the filler panels.

4. Remove the front and back rack doors if necessary.
5. Follow the instructions for marking the location without a template, see Marking the location without a rack-mounting template.

Marking the location without a rack-mounting template:

You might need to mark the location without a template. Use the procedure in this section to perform this task.

A rack-mounting template is not included with this system. These systems are one EIA unit tall.

To determine the mounting location, complete the following steps:

1. Determine where in the rack to place the system. Record the EIA location.

Note: An EIA unit on your rack consists of a grouping of three holes.

2. Facing the front of the rack and working from the right side, place a supplied self-adhesive dot next to the top hole of the EIA unit.

Note: The self-adhesive dots are used to aid in identifying locations on the rack. If you no longer have any of the dots, use some other form of marking tool to aid you in identifying hole locations (for example, tape, a marker, or pencil). If you are installing slide rails, place mark or self-adhesive dot on lower and the middle hole of each EIA unit.

3. Place another self-adhesive dot next to the bottom hole of the above the EIA unit.

Note: If you are counting the holes, begin with the hole identified by the first dot and count up two holes. Place the second dot next to the third hole.

4. Repeat steps 1 through 4 for the corresponding holes located on the left side of the rack.
5. Go to the back of the rack.
6. On the right side, find the EIA unit that corresponds to the bottom EIA unit marked on the front of the rack.
7. Place a self-adhesive dot at the bottom EIA unit.
8. Place a self-adhesive dot at the top hole of the EIA unit.
9. Mark the corresponding holes on the left side of the rack.

Installing the slide-rail kit into the rack

You might need to instal the slide-rail kit into the rack. Use the procedure in this section to perform this task.

If you are installing a system that has the slide-rail kit, complete the procedures in the following subsections. If you are installing a system that has the fixed-rail kit, refer to "Installing the fixed-rail kit to the rack" on page 90.

Installing the slide rails into the rack:

You might need to install slide rails into the rack. Use the procedure in this section to perform this task.

Attention: Installing the rails in the rack is a complex procedure. To install the rails correctly, you must perform each task in the following order.

To install the slide rails into the rack, complete the following steps:

1. Insert the right-slide rail **A** marked "right" into the back-right rack mounting flange **B** locations. The two rail pins will protrude through the bottom and middle holes **B** on the EIA unit.

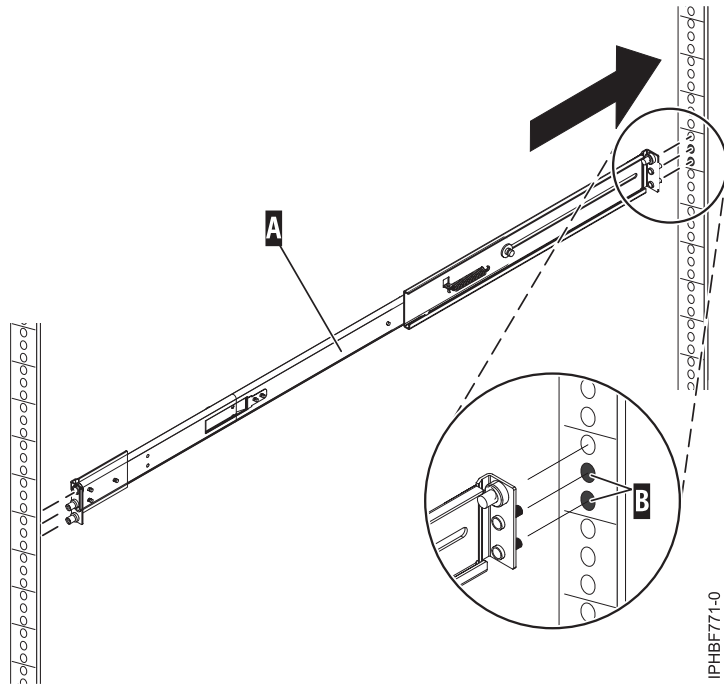

Figure 79. Installing the right-slide rail into the back of the rack

2. Push on the end of the rail **A** to compress the rail's spring-loaded mechanism and insert the rail into the front-right rack mounting flange **B** locations. The rail will decompress and the two rail pins will protrude through the bottom and middle holes **B** on the EIA unit.

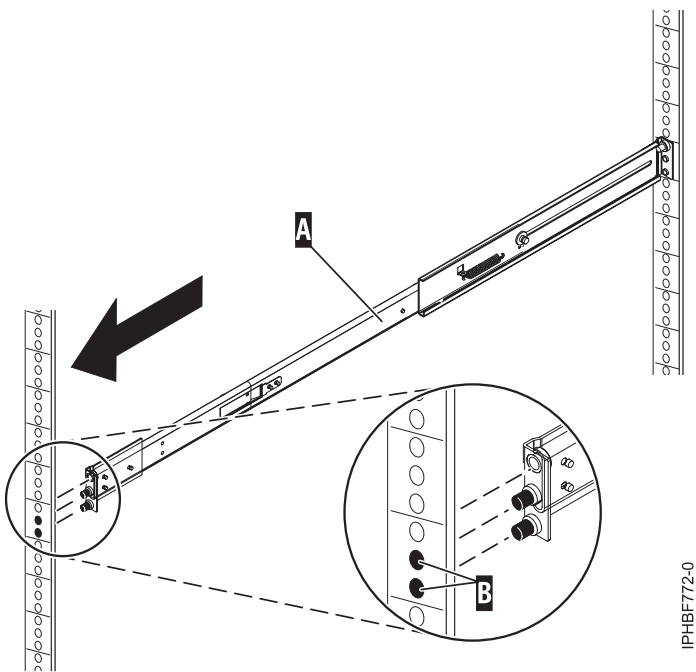

Figure 80. Installing the right-slide rail into the front of the rack

3. Repeat these steps to install the left-slide rail marked "left" into the rack.

4. From the front of the rack, install one latch strike **C** to the top pin of front of the right-slide rail **A** using the captive screw **D**. Finger-tighten the captive screw **D**.

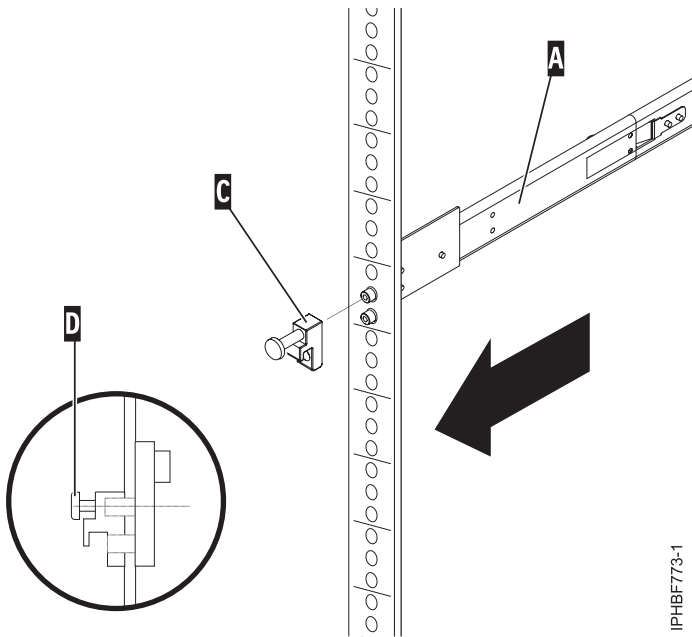

Figure 81. Installing the latch strike to the front of the rails.

5. Repeat steps 1 and 2 to install the latch strike on the front of the left-slide rail.
6. Move to the back of the rack.
7. Insert screw **F** to attach the cable-management arm mounting bracket **E** to the back of the left rail **G**. Finger-tighten the screw.

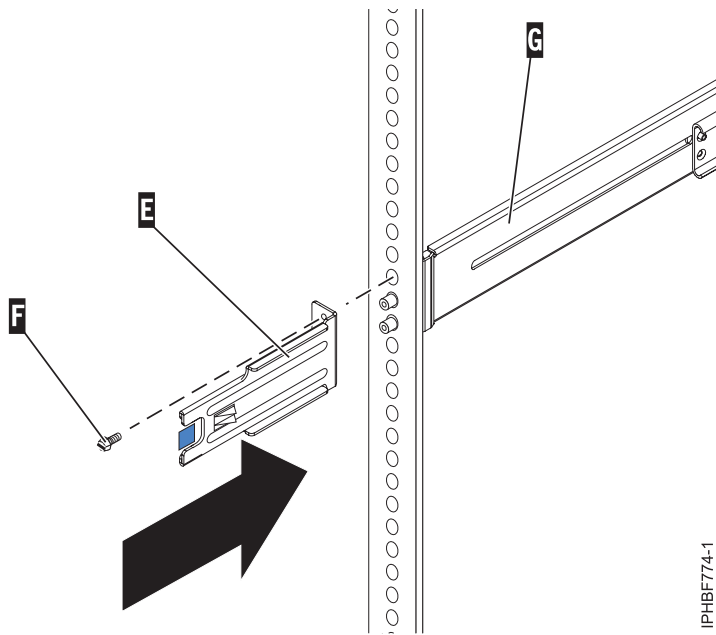

Figure 82. Attaching the cable-management bracket to the back-left rail.

8. Insert screw **I** to attach the cable-management arm support bracket **H** to the back-right rail **A**. Finger-tighten the screw.

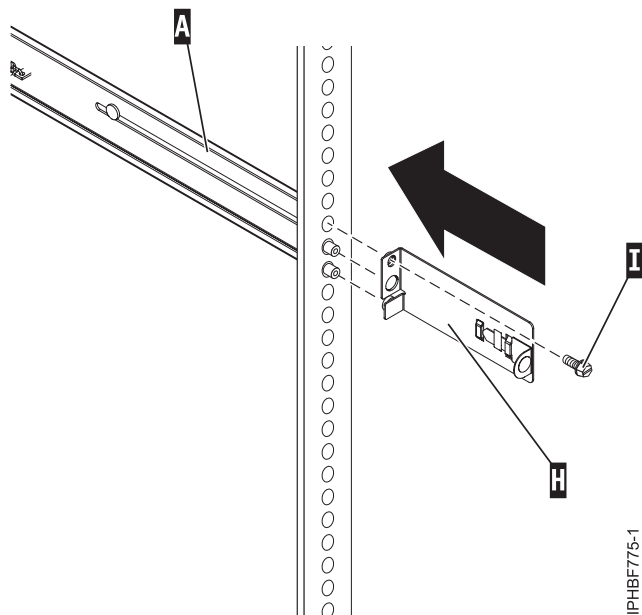

Figure 83. Attaching the cable-management support bracket to the back-right rail.

Note: The cable-management arm support bracket can be used to secure the cable-management arm during transport. If the mechanism is engaged after the cable-management arm is installed, you will not be able to slide the system from the rack.

Installing the system unit on the slide rails:

You might need to install the system unit on the slide rails. Use the procedure in this section to perform this task.

Before installing the system unit on the slide rails, ensure that the stabilizers are extended and the rack stabilizer bracket is attached to the bottom front of the rack to prevent the rack from falling forward when the rails are pulled out of the rack. Refer to Installing the rack.

To install the system unit on the slide-rail assembly, complete the following steps:

1. From the front of the rack, fully extend the slide rails until the rails lock into place in the extended position **A**.

CAUTION:

The latch strikes on the front of the rail and the cable-management arm brackets must be installed *before* installing a system unit onto the rails. If these parts are not installed, the installation may cause the rails to compress and the system may fall out of the rack.

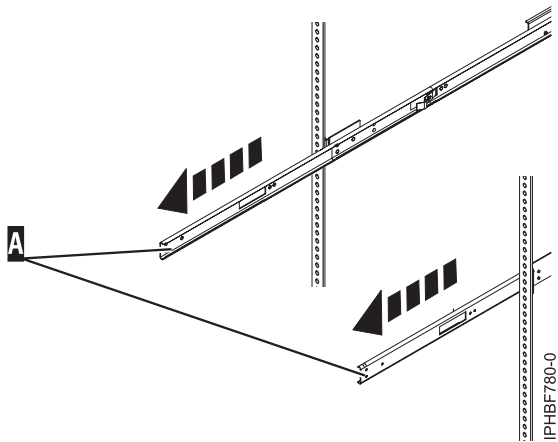

Figure 84. Extending the slide rails.

2. Lift the system to the height of the rails and position the set of wheels **B** at the back of the system between the rail guides.

CAUTION:

This unit weighs approximately 17 kg (37 pounds), be sure you can safely support this weight when placing the system unit into the rack.

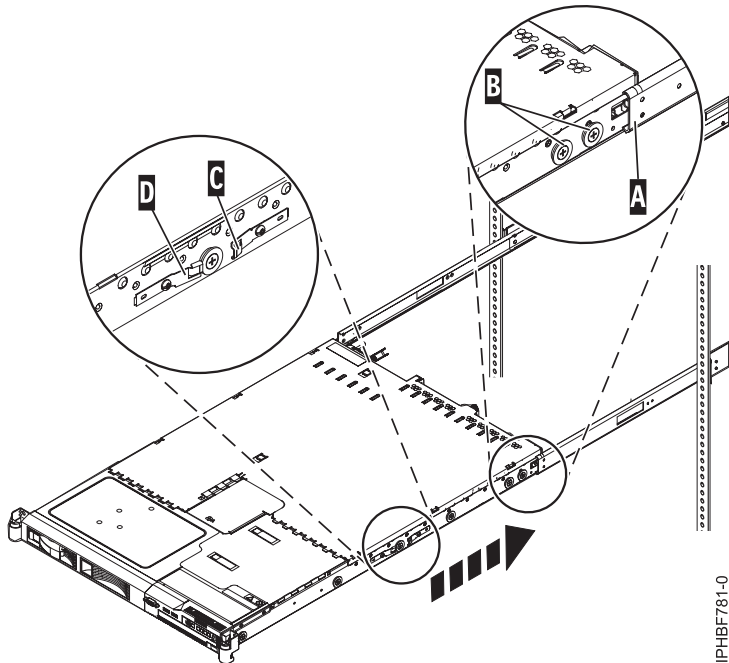

Figure 85. Installing the system on the slide rails.

3. Push the system into the slide rails until the slide release catches **C** lock into place. This locks the system in the service position on the slides. You will hear an audible click.
4. Press the front-slide rail release latches **D** on both sides of the slides rails.

Note: Take care not to pinch your fingers as you are holding down the release latches and pushing the system into the rack.

5. Slide the server into and out of the rack to verify that the server moves freely without binding.

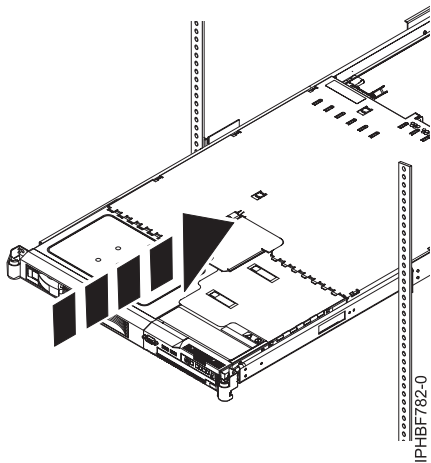

Figure 86. Slide the system into the rack.

Attention: Do not, under any circumstances, force the system unit into the slide rails. If the system does not glide freely into the rack, completely remove the system from the rails. After the system is clear of the rails, reposition the system, then reinsert the system into the rails. Repeat this process until the system glides freely into the rack.

6. Completely tighten each the four screws were installed in the front and back of both rails.

7. Push the system unit into place until the rack latches **F** lock into place.

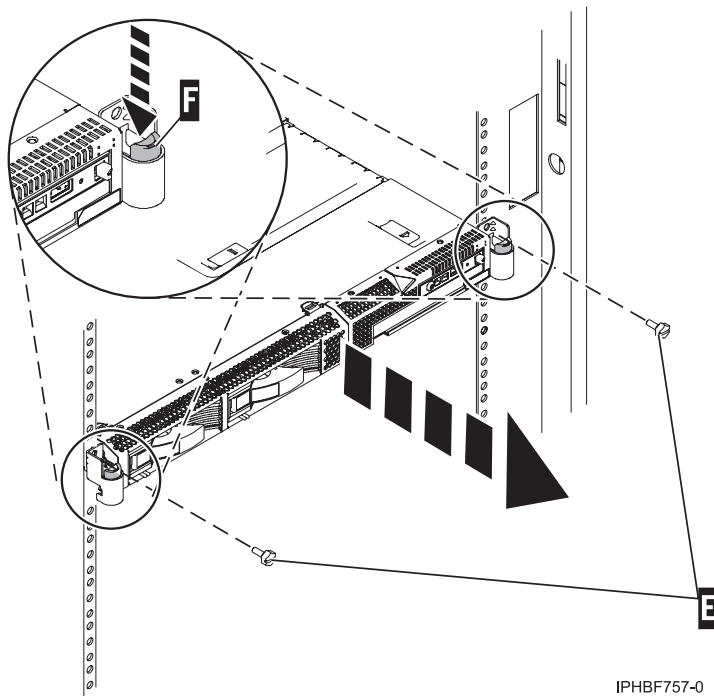

Figure 87. Rack latches and screws.

8. If the rack will be transported, insert and tighten the two rack security screws **E**.

Installing the cable-management arm:

You might need to install the cable-management arm. Use the procedure in this section to perform this task.

To install the cable-management arm with the slide-rail kit, complete the following steps:

1. From the back of the rack, align the tabs **K** on the cable-management arm mounting plate **J** with the slots on the back of the system unit. Slide the mounting plate **J** to the left to engage the tabs. Tighten the thumbscrew **L** to secure the mounting plate to the server.

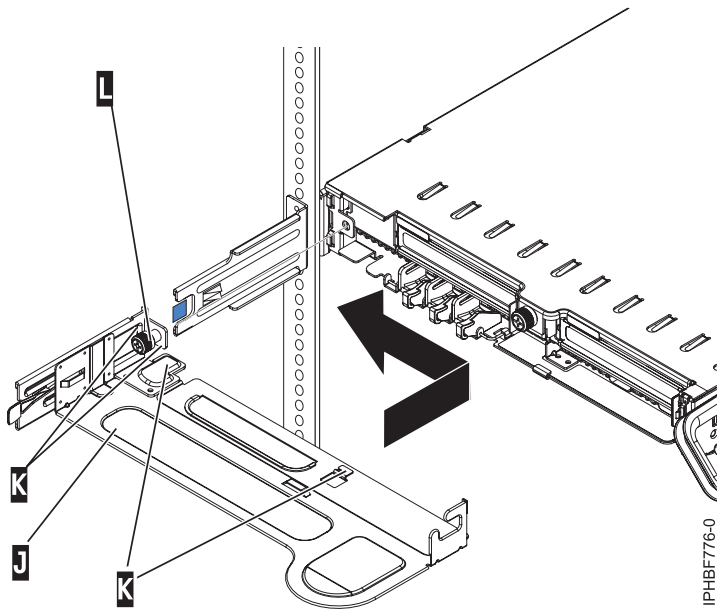

Figure 88. Attaching the cable-management arm mounting plate.

2. Align the ends of the cable-management arm N with the two mounting latches M. Slide the arm toward the server until both latches L lock into place in their mounting brackets with audible clicks. To verify installation of the cable-management arm, fully extend the server from the front of the rack and ensure that the arm moves freely without binding. Push the server back into the rack cabinet.

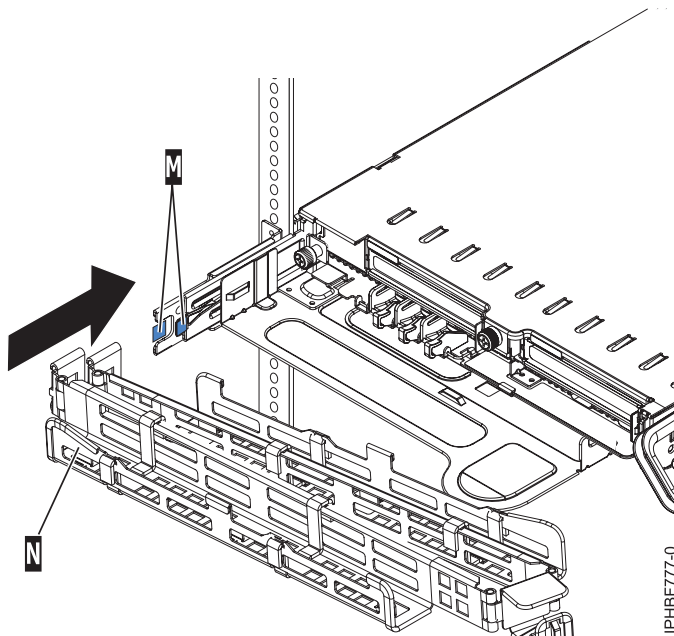

Figure 89. Attaching the cable-management arm.

3. Loosen the cable straps O on the cable-management arm N to prepare to cable the system.

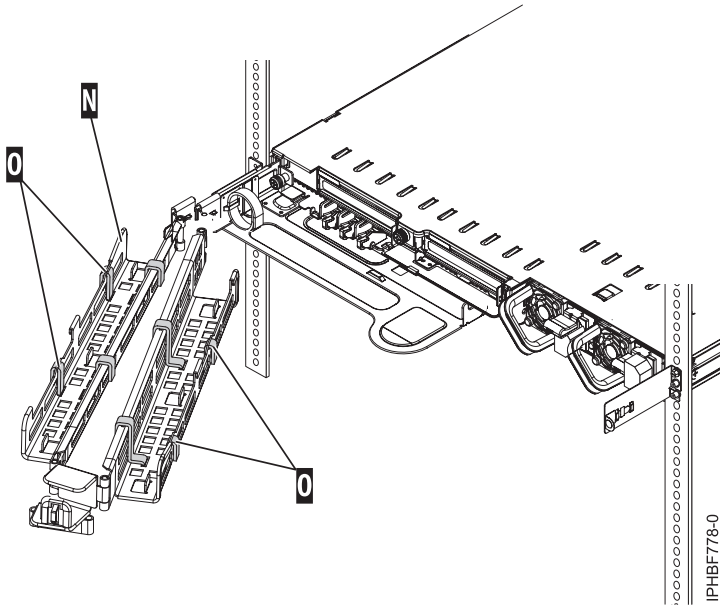

Figure 90. Loosening the cable straps.

4. Cable the system. See Connect the power cables to the system and return here.
5. For additional security when you move or ship the rack, you can secure the cable-management arm to the support bracket **P** by inserting the tab **Q** on the arm into the support bracket **P** and installing the latch pin **R**.

Note: Performing this step prevents the system from sliding out of the rack. The cable-management arm must be disengaged from the support bracket for the system to slide out of the rack.

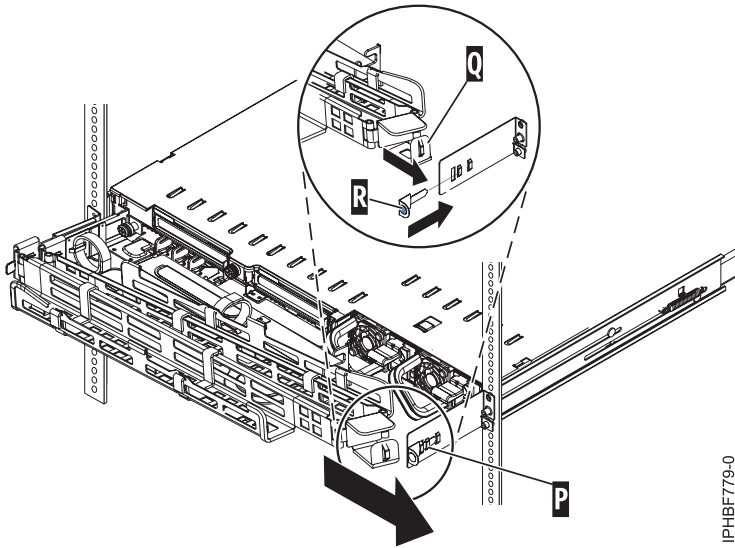

Figure 91. Securing the cable-management arm.

Installing the fixed-rail kit to the rack

You might need to install the fixed-rail kit into a rack. Use the procedure in this section to perform this task.

If you are installing system that has fixed rails, complete the procedures in the following subsections. If you are installing a system that has slide rails, refer to “Installing the slide-rail kit into the rack” on page 82.

Attaching the mounting hardware to the rack:

You might need to attach the mounting hardware to the rack. Use the procedure in this section to perform this task.

Attention: Installing the rails in the rack is a complex procedure. To install the rails correctly, you must perform each task in the following order.

To install the rack-mounting hardware into the rack, complete the following steps:

1. Set the system rails to allow correct assembly with the rack and system unit. Refer to Figure 92.
2. Pull the back latch assembly release tab **A** to the retracted position and lock the latch assembly **B**. The back-alignment pins should be fully retracted.

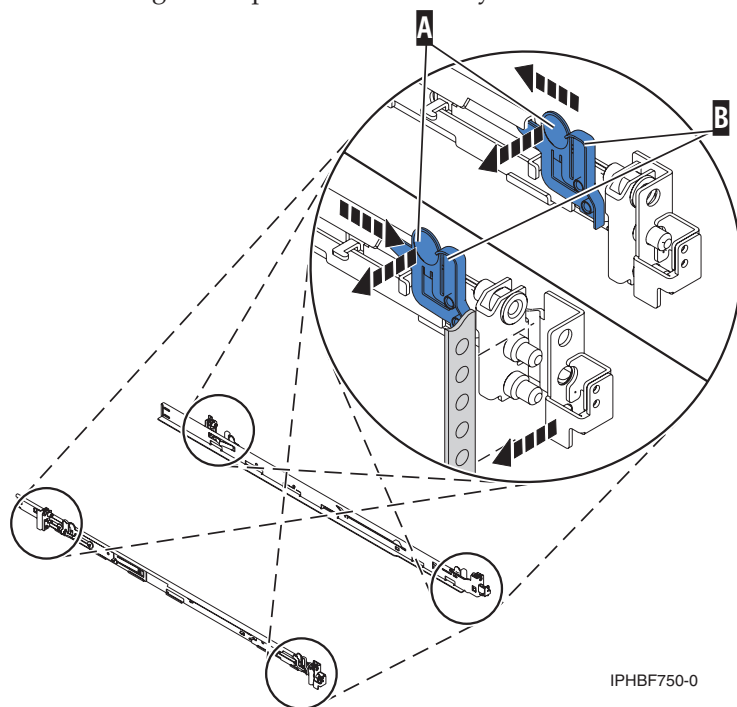

Figure 92. System rail assembly setup

3. Pull the front latch assembly release tab to the retracted position and lock the latch assembly. The front-alignment pins should be fully retracted.

Note: Although the rail installation can be completed by one person, it is recommended that one person hold the rail in place in the front position while another locks the latch assembly in place.

4. Pull the back latch assembly release tab to the retracted position and lock the latch assembly. The back-alignment pins should be fully retracted.
5. From the back of the rack, insert the back-alignment pins (Figure 92) into the hole at the back of the rack identified by the self-adhesive placement dot that you previously installed. Have a second person hold the rail securely in the back hole.

Note: It may take some force to manipulate the alignment pins into their mounting locations. Be careful not to bend the alignment pins when inserting them into the rack.

6. Press the release tab **A** (Figure 92 on page 91) to extend the back-alignment pins into the back of the rack. Ensure that the pin passes through the correct hole in the rack frame.

Note: After the back-alignment pins are in place, the rail may be adjusted to fit the rack depth by sliding the rail forward to align the front-alignment pins.

7. From the front of the rack, align the front-alignment pins of the rail with the holes at the front of the rack identified by the self-adhesive placement dot that you previously installed. The back EIA location will be one position higher than the front rail position. Ensure that the rails are level.
8. Press the release tab **A** (Figure 92 on page 91) to extend the two front-alignment pins into the front of the rack. Ensure that the pins have passed through the correct holes in the rack frame.
9. From the back of the rack, finger-tighten one of the rail-retaining screws into the hole that is located between the two back-alignment pins.

Note: This action is necessary to ensure the rail stays in the correct location.

10. Repeat steps 1 on page 91 through 9 for the rail assembly for the opposing rail assembly.

Note: If more than one person is available to install the rails, one person can be located at the back of the rack and one at the front of the rack to speed the installation of multiple sets of rails.

Note: If you will be transporting the rack to a new location or if the installation is located in an earthquake-prone area, secure each rail by attaching a system-retaining screw **C** into the hole position **D** between the two front-alignment pins as shown in Figure 93.

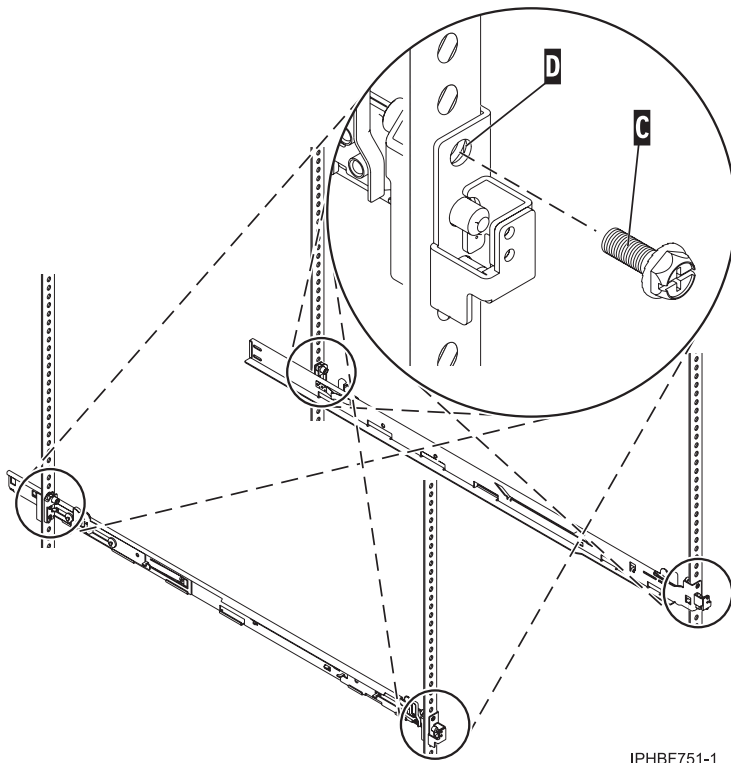

IPHBF751-1

Figure 93. Securing the system rails.

Note: Depending on the type of rack that the rails are installed into, there may be leftover parts that were included for other types of racks.

Attaching the mounting hardware to a tapped-hole rack:

You might need to attach the mounting hardware to the rack. Use the procedure in this section to perform this task.

Attention: Installing the rails in the rack is a complex procedure. To install the rails correctly, you must perform each task in the following order.

To install the rack-mounting hardware into a tapped-hole rack, complete the following steps:

1. Press latch **A** and hold the rail slide to prevent the rail slide from moving to the extended position.

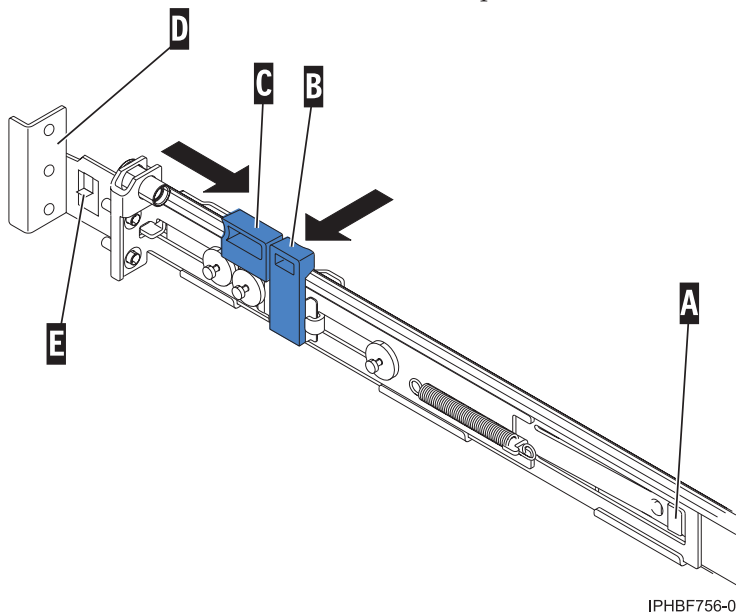

Figure 94. Tapped-hole rack rail assembly setup

2. Press tab **B** away from the rail.
3. Press tab **C** away from the back rail flange.
4. Pull the back latch assembly release tab to the retracted position and lock the latch assembly. The back-alignment pins should be in the fully retracted (open) position.

Attention: Do not remove tab **E** unless you are installing the rails into a tapped-hole rack with a thickness greater than 3.175 mm (0.125 in.). If you remove tab **E**, you must insert an M6 screw through all of the bottom holes in the rail-mount flange on each of the four flanges of the rack.

5. From the back of the rack, insert the back-alignment pins (Figure 94) into the hole at the back of the rack identified by the self-adhesive placement dot that you previously installed. Have a second person hold the rail securely in the back hole.
6. Press the release tab **A** (Figure 94) to extend the back-alignment pins into the back of the rack. Ensure that the pin passes through the correct hole in the rack frame.

Note: After the back-alignment pins are in place, the rail can be adjusted to fit the rack depth by sliding the rail forward to align the front-alignment pins.

7. From the front of the rack, align the front-alignment pins of the rail with the holes at the front of the rack identified by the self-adhesive placement dot that you previously installed. The back EIA location will be one position higher than the front rail position. Ensure that the rails are level.
8. Press the release tab **A** (Figure 94) to extend the two front-alignment pins into the front of the rack. Ensure that the pins have passed through the correct holes in the rack frame.

9. From the back of the rack, finger-tighten one of the rail-retaining screws into the hole that is located between the two back-alignment pins.

Note: This action is necessary to ensure the rail stays in the correct location.

10. Repeat the previous steps for the rail assembly on the opposing rail assembly.

Note: If more than one person is available to install the rails, one person can be located at the back of the rack and one at the front of the rack to speed the installation of multiple sets of rails.

Installing the cable-management arm:

You might need to install the cable-management arm. Use the procedure in this section to perform this task.

To install the cable-management arm, complete the following steps:

1. From the back of the rack, locate the cable-management arm flange **A** located on the fixed back portion of the left system rail assembly (viewing from the back of the rack).
2. Attach the cable-management arm clasp **B** to the rail by pushing the clasp onto the rail until it locks into place.

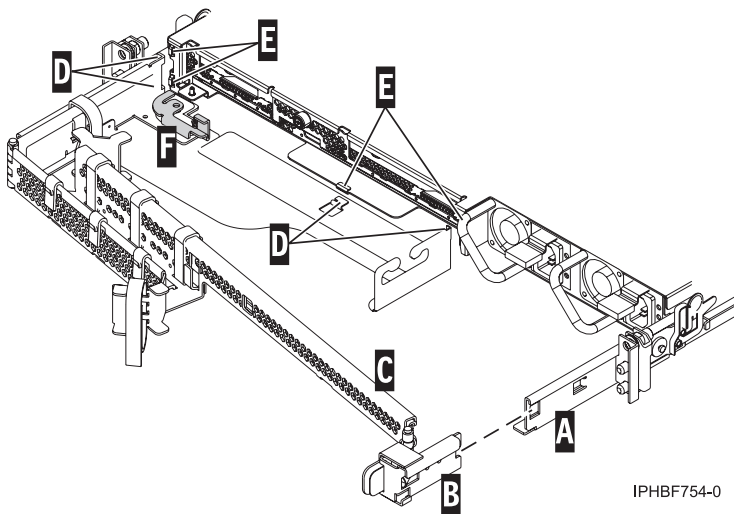

Figure 95. Cable-management arm and system unit.

3. Attach the other end of the cable-management arm **C** to the back of the system unit by doing the following:
 - a. Align the tabs **D** on the cable-management arm with the slots **E** on the back of the system unit.
 - b. Slide the cable-management arm to the left, securing it into place. Make sure all the tabs fit into the slots.
 - c. Push the locking lever **F** into the locked position.

Note: Ensure that the cable-management arm **C** is level so that it moves freely.

Installing the system unit on the rail assembly:

You might need to install the system unit on the rail assembly. Use the procedure in this section to perform this task.

Before installing the system unit on the rail assembly, ensure that the stabilizers are extended and the rack stabilizer bracket is attached to the bottom front of the rack to prevent the rack from falling forward when the rails are pulled out of the rack. Refer to Installing the rack.

To install the system unit on the rail assembly, complete the following steps:

1. Lift the system unit, and position the back of the system unit over the rails.

CAUTION:

This unit weighs approximately 17 kg (37 pounds) be sure you can safely support this weight when placing the system unit into the rack.

If you are installing a system into a tapped hole rack, *do not* use the area A to support the system during installation. The back of the system chassis will be located on position B and area C is the acceptable installation support area.

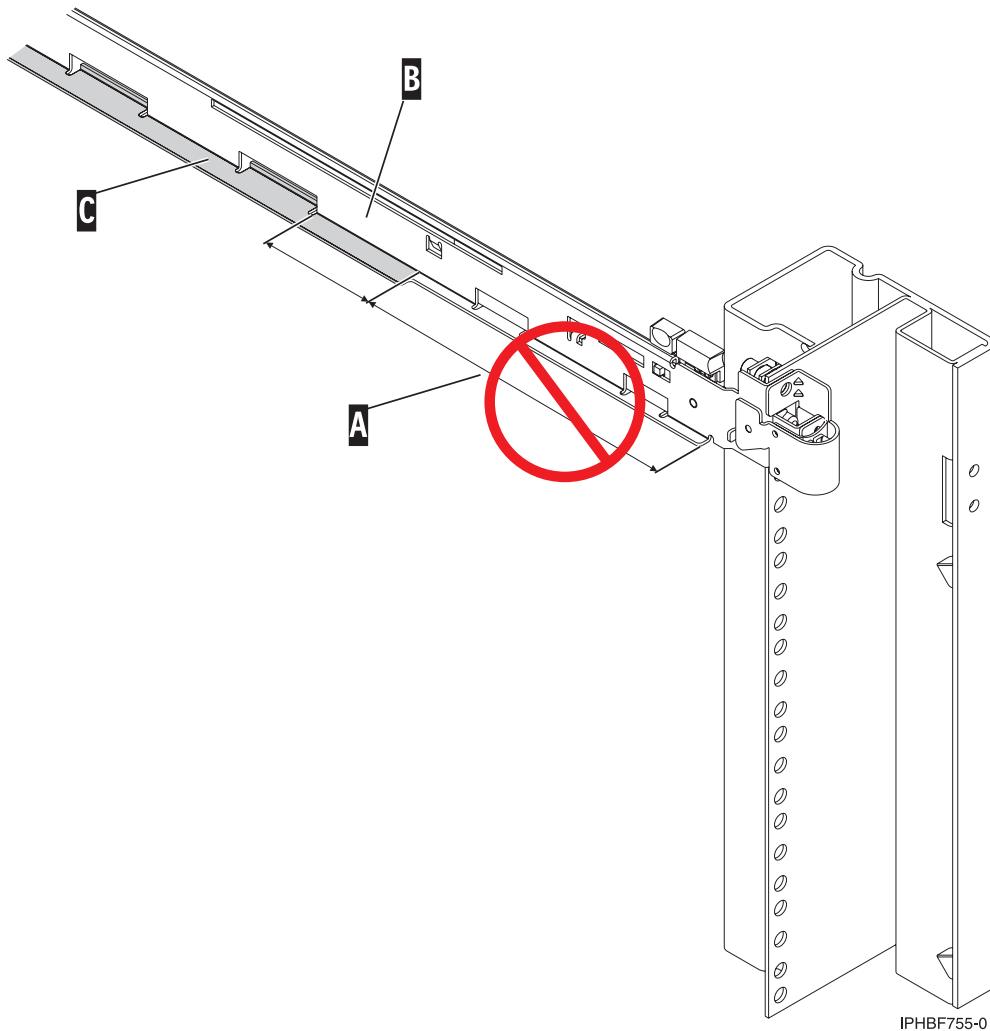

Figure 96. Tapped-hole rack installation areas.

2. Simultaneously depress the safety latches D located near the middle of each side of the system, and slide the system unit into the rack.

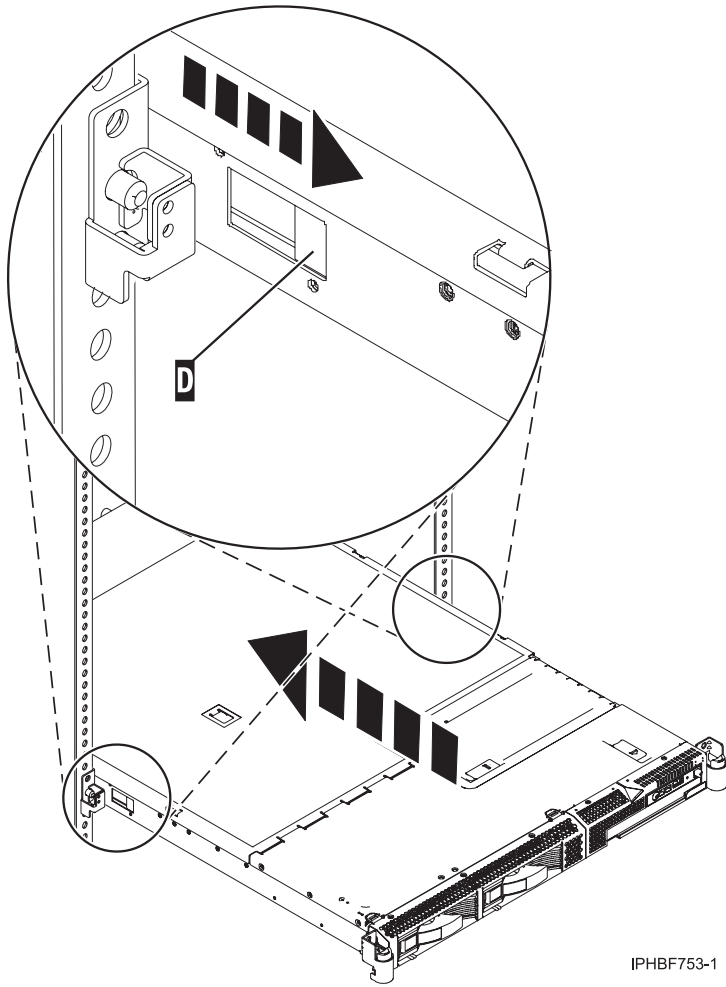

Figure 97. Rack safety latches.

Attention: Do not, under any circumstances, force the system unit onto the rails. If the system drawer does not glide freely into the rack, completely remove the drawer from the rails. After the drawer is clear of the rails, reposition the system, then reinsert the system onto the rails. Repeat this process until the system drawer glides freely into the rack.

3. During the installation process you should hear the safety guides engage into the rails. You may have to move the drawer side-to-side to ensure the safety guides engage properly. The back of the system should be in the **A** area of the rails.
4. Push the system unit into place until the rack latches **F** lock into place.

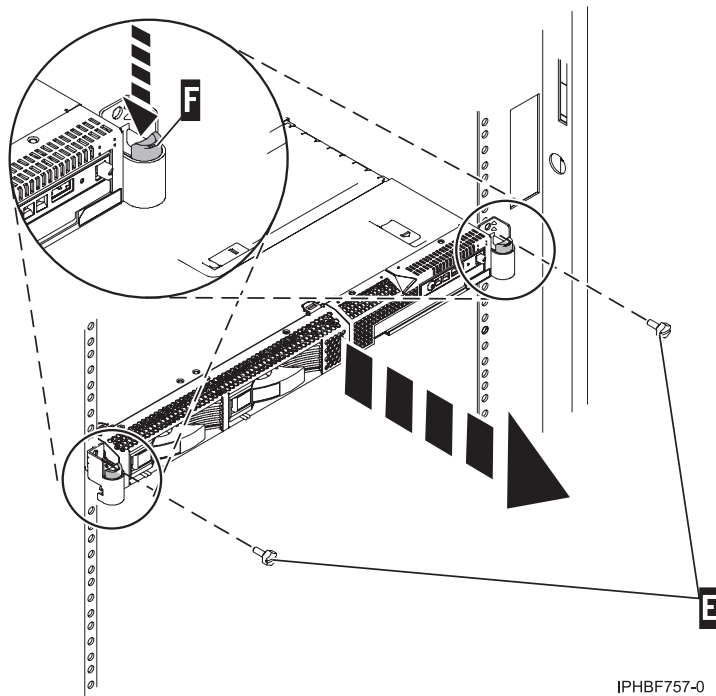

Figure 98. Rack latches and screws.

5. Replace and tighten the two screws E that secure the system unit to the rack as shown in Figure 98.

Installing the 51x, 710, or 9110-51A into a rack

You might need to install the system into a rack. Use the procedure in this section to perform this task.

Use this procedure if you are installing the system into an existing rack. If the rack is not installed, go to the instructions for installing the rack, and then return to this procedure for instructions on installing the system unit into the rack.

To install the system into a rack, complete following procedure:

1. Read the "Rack Safety Notices" on page 1. Failure to read these notices could cause damage to the equipment or injury to the installer.
2. Complete a parts inventory (See Complete a parts inventory).
3. Locate the rack-mounting template, the rack-mounting hardware kit, and the system rail assemblies that were included with your system unit.

The system rails are front-to-back and left-to-right side dependent. The rails are labeled "left" and "right" to indicate their placement when you face the front of the rack. There two large latch assemblies at the back of each rail. These latch assemblies go in the back of the rack.

4. Determine where you will locate the expansion unit in the rack. See Determining location.
5. Mark the location. See Mark the location using rack-mounting template. If you do not have the rack-mounting template, see Mark the location without a rack-mounting template.

Determining the location

You might need to determine where to install the system in the rack. This section includes procedures so that you can perform these tasks.

Before installing the system unit or expansion unit into a rack, complete the following steps:

1. Read "Rack Safety Notices" on page 1. Failure to read these notices could cause damage to the equipment or injury to the installer.
2. Plan where you will place the units. Place the larger and heavier units in the lower part of the rack. The system units are two EIA units high.
3. If necessary, remove the filler panels to allow access to the inside of the rack enclosure where you plan to place the unit.

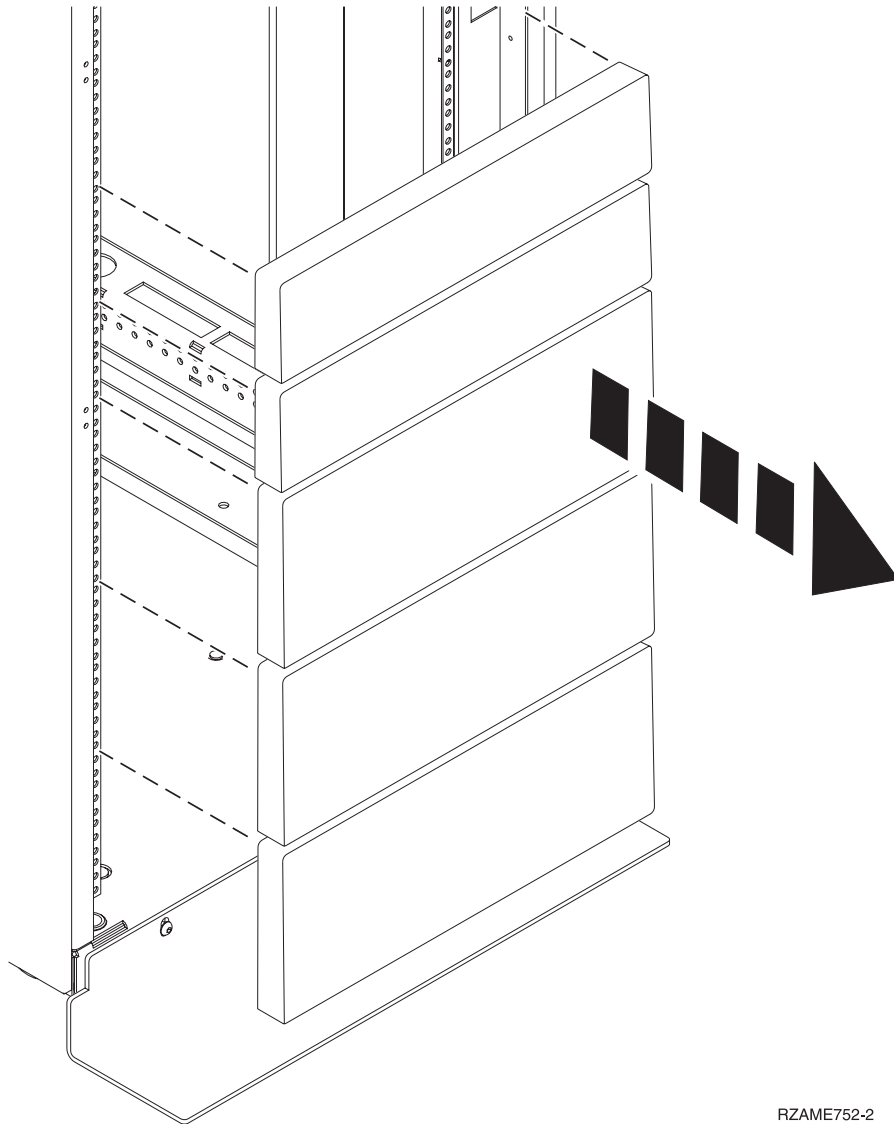

RZAME752-2

Figure 99. Removing the filler panels.

4. Remove the front and back rack doors if necessary.
5. Use the rack-mounting template to mark the location (see Mark location using rack-mounting template.) Or, if you do not have a rack-mounting template, follow the instructions for marking the location without a template (see Mark location without rack-mounting template).

Marking the location using a rack-mounting template:

You might need to mark the installation location using a rack-mounting template. Use the procedure in this section to perform this task.

If you have a rack-mounting template, review the following information:

1. Using the rack-mounting template, determine where in the rack to place the system unit. Install units in the lower part of the rack first. Place larger and heavier units in the lower part of the rack.

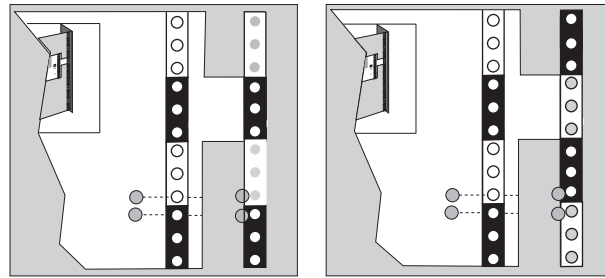

IPHBF502-0

Figure 100. Example of a rack-mounting template.

Note: The front of the rack-mounting template has printed illustrations designed to help you identify the EIA location holes to be used when you add units to the rack. **Do not** use the rack-mounting template without completing the following steps.

2. Note the following when using the rack-mounting template:
 - Each black or white unit on the template is equal to one EIA unit.
 - Each EIA unit consists of three holes.
 - The EIA units illustrated on the template must be aligned with the EIA units located on the rack.
 - It is not necessary to align like-colored EIA units. For example, a black EIA unit on the rack-mounting template can be aligned with a white EIA unit located on the rack.
 - The template is two-sided. When using the template, ensure that the appropriate side of the template is facing out.

Figure 101 shows one EIA unit and four EIA units. Depending on the rack manufacturer, the EIA units might be separated either by color or by a line. The holes along the rail are not evenly spaced. If your rack has no color or line separation between EIA units, each EIA unit begins where the hole spacing **A** is closest together.

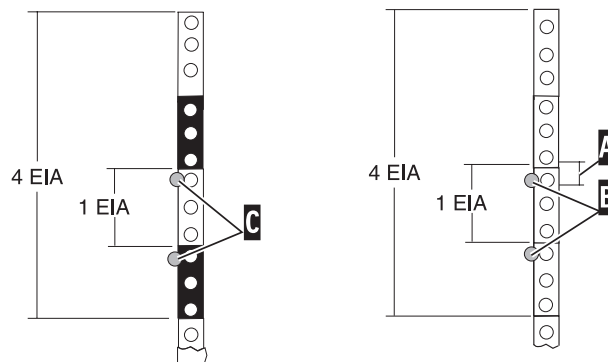

IPHBF503-0

Figure 101. EIA units.

To use the rack-mounting template, complete the following steps:

- a. Remove the protective coating from each adhesive strip located on the back of the rack-mounting template. Lightly press the template into position on the rack. Ensure that both the left and right sides are at the corresponding EIA locations.

Note: The tabs on each side of the template show a notch to indicate the correct spacing between the front flanges.

- b. Locate the dots, printed on the left and right side of the template. Place a self-adhesive dot directly across from the template's printed dots on or near the rack's EIA numbering strip. You will be using these dots to aid in correctly positioning the rail-alignment pins located on the front of each rail.
- c. Remove the rack-mounting template from the front of the rack. The front of your rack now contains dots.
- d. Mount the rack-mounting template to the rack's back EIA frame. Place the rack-mounting template at the same EIA-numbered location that was used on the front of the rack.
- e. Wrap a self-adhesive dot directly across from the template's printed dots. Ensure that a portion of the self-adhesive dot wraps around the rack frame so that it can be seen from the front of the rack.
- f. Remove the rack-mounting template from the back of the rack. The back of your rack now contains dots that have been partially wrapped around the frame.

Marking the location without a rack-mounting template:

You might need to mark the location without a template. Use the procedure in this section to perform this task.

If you do not have a rack-mounting template, complete the following steps:

1. Determine where in the rack to place the system. Record the EIA location.
2. Note the following information:
 - Each EIA unit consists of three holes.
 - These systems are two EIA units high.
3. Facing the front of the rack and working from the right side, place a supplied self-adhesive dot next to the middle hole of the bottom EIA unit that you selected.

Note: The self-adhesive dots are used to aid in identifying locations on the rack. If do not have any of the dots, use some other form of marking tool to aid you in identifying hole locations (for example, tape, a marker, or pencil).

4. Place another self-adhesive dot next to the bottom hole of the above EIA unit. There will be one hole between the dots.
5. Repeat steps 3 through 4 for the corresponding holes located on the left side of the rack.
6. Go to the back of the rack. On the right side, find the EIA unit that corresponds to the bottom EIA unit marked on the front of the rack.
7. Place a self-adhesive dot at the middle hole of the bottom EIA unit.
8. Place a self-adhesive dot at the bottom hole of the next (above) EIA unit.
9. Mark the corresponding holes on the left side of the rack.

Attaching the mounting hardware to the rack

You might need to attach the mounting hardware to the rack. Use the procedure in this section to perform this task.

Attention: Installing the rails in the rack is a complex procedure. To install the rails correctly, you must perform each task in the following order. Failure to do so might cause rail failure and potential danger to yourself and the system unit.

To install the rack-mounting hardware into the rack, complete the following steps:

1. Setup the system rails to allow correct assembly with the rack and system unit. Refer to Figure 102 and then follow these steps:
 - a. Fully extend each rail assembly.
 - b. Pull the back latch assembly release tab **A** to the retracted position and lock the latch assembly **B**. The back-alignment pins should be fully retracted.
 - c. Pull the front latch assembly release tab to the retracted position and lock the latch assembly. The front-alignment pins should be fully retracted.

Note: Although the rail installation can be completed by one person, it is easier if one person holds the rail in place in the front position while another person locks the latch assembly in place.

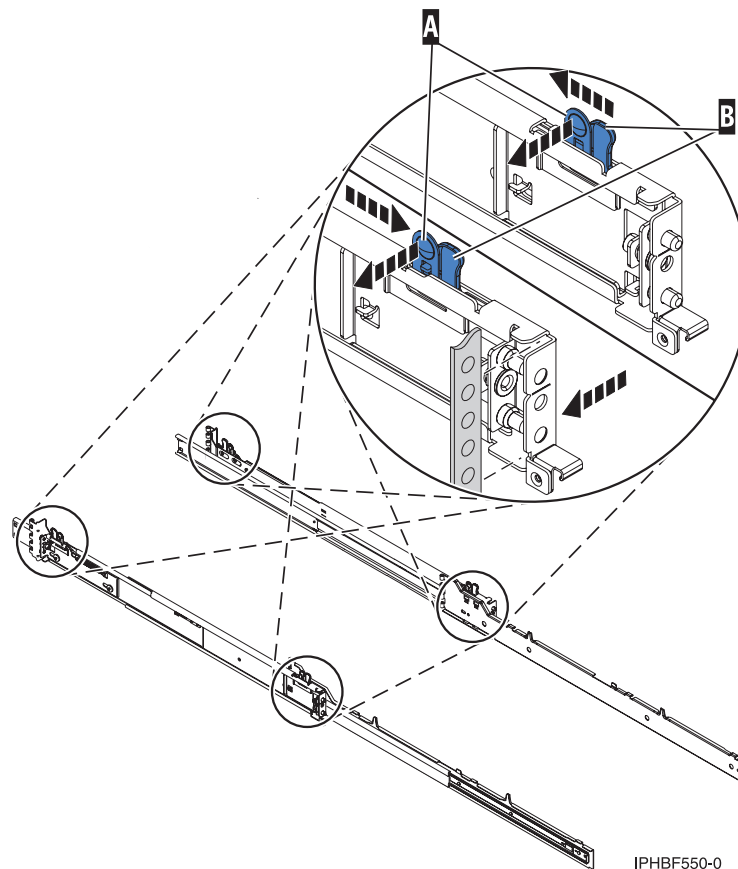

Figure 102. System rail assembly setup.

2. From the back of the rack, insert the front-alignment pins (Figure 102) into the hole at the front of the rack identified by the self-adhesive placement dot that you previously installed. Have a second person hold the rail securely in the front hole.
3. Press the release tab **A** (Figure 102) to extend the front-alignment pins into the front of the rack. Ensure that the pin passes through the correct hole in the rack frame.
4. From the front of the rack, align the back-alignment pins of the rail with the holes at the back of the rack identified by the self-adhesive placement dot that you previously installed. The back EIA location will be one position higher than the front rail position. Ensure that the rails are level.
5. Press the release tab **A** (Figure 102) to extend the two back-alignment pins into the back of the rack. Ensure that the pins have passed through the correct holes in the rack frame.
6. From the back of the rack, finger tighten one of the rail-retaining screws into the hole that is located between the two back alignment pins.

7. Repeat steps 2 on page 101 through 6 on page 101 for the rail assembly on the other side of the rack.

Note: If you are transporting the rack to a new location, secure each rail by attaching a system-retaining screw **C** into the hole position **D** between the front-alignment pins as shown in Figure 103.

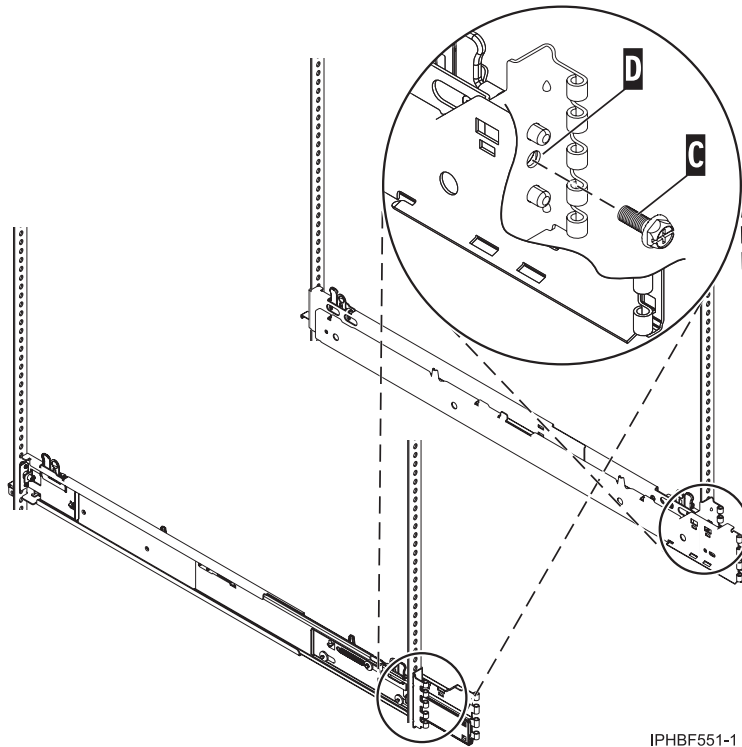

Figure 103. Securing the system rails.

Installing the system on the rail assembly

You might need to install the system on the rail assembly. Use the procedure in this section to perform this task.

Before installing the system on the rail assembly, ensure that the stabilizers are extended and the tip plate is attached to the bottom front of the rack to prevent the rack from falling forward when the rails are pulled out of the rack. Refer to *Installing the rack*.

To install the system on the rail assembly, complete the following steps:

1. Fully extend both rails.
2. Using two people, lift the system unit, and position the system on the extended rails.

CAUTION:

This unit weighs between 17.7 kg (39 pounds) and 21.7 kg (48 pounds). Two people are required to safely move it.

3. Align the slots on the system unit chassis with the tabs **A** on the rails.
4. Lower the system unit so that the tabs slide into the slots on the chassis **B**. The system unit will lock into place.
5. Simultaneously release the blue safety latches **C** located near the front of the rail assembly, and push the system unit into the rack.

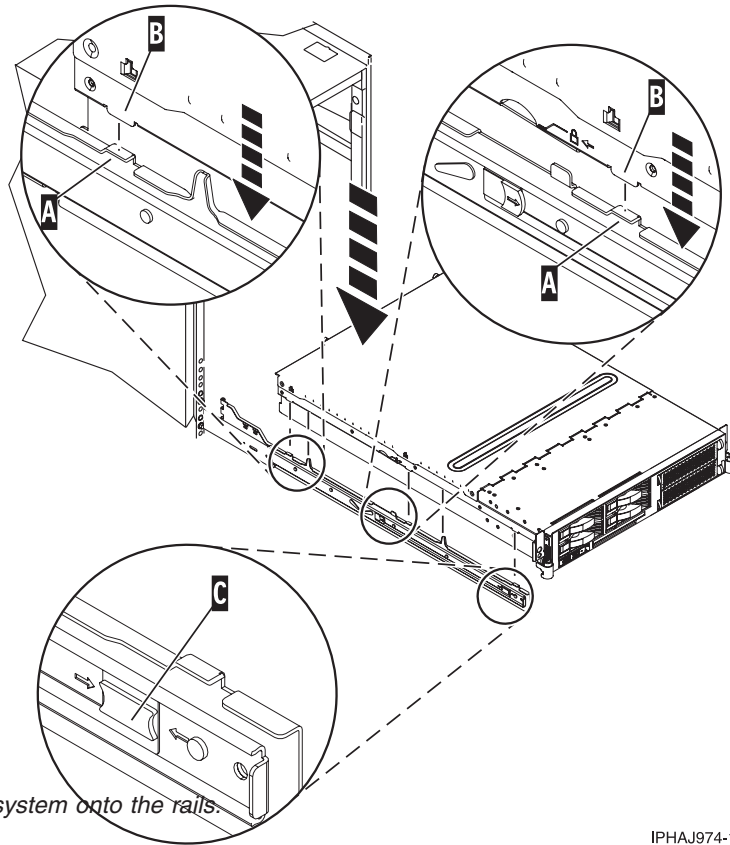

Figure 104. Lowering the system onto the rails.

IPHAJ974-1

6. Slide the system unit into and out of the rack two or three times to align the system unit to the rails. The system unit should glide on the rails.

Attention: *Do not*, under any circumstances, force the rails. If the system drawer does not glide freely into the rack, completely remove the drawer from the outer rails. After the drawer is clear of the outer rails, reposition the system, then reinsert the inner rails. Repeat this process until the system drawer glides freely into the rack

7. Push the system unit into the rack.

After the system rails are installed, do not extend them past their safety latches. The safety latches prevent the rails from overextending and separating, thereby preventing the system unit from being pulled out too far and being dropped.

Installing the cable-management arm

You might need to install the cable-management arm. Use the procedure in this section to perform this task.

To install the cable-management arm, complete the following steps:

1. From the back of the rack, locate the cable-management arm flange **C** located on the fixed back portion of the left system rail assembly **B**.

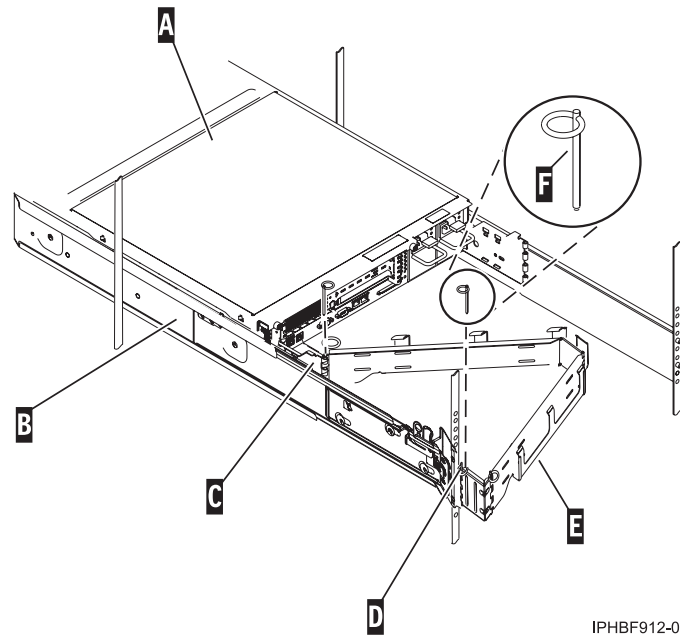

Figure 105. Installing the cable management arm.

2. Use pin F to pin the cable-management arm E to the rack frame D.

Note: If access to the back of the rack is obscured by a large number of existing cables, it might be easier to remove the small connecting hinge from the cable-management arm and attach it first. Then, you can attach the remaining section of the cable-management arm to the connecting hinge.

3. Use pin F to pin the other end of the cable-management arm to the flange C attached to the sliding portion of the left system rail assembly B.

Note: Ensure that the cable-management arm is level so that it moves freely.

Installing the 515 or 52x into a rack

You might need to install the system into a rack. Use the procedure in this section to perform this task.

This topic describes how to install the system into a rack. You can perform this task yourself, or contact a service provider to perform the task for you. You might be charged a fee by the service provider for this service.

This procedure assumes that you are installing the system into an existing rack. If the rack is not installed, go to the instructions for installing a rack and then return to this procedure for instructions on installing the system unit into the rack. See *Installing a rack*

Note: This procedure applies only to the models that are designed to be mounted in a rack. Do not attempt to install a stand-alone model in a rack unless you have the conversion kit and have converted the stand-alone system unit for rack installation. See “Converting the stand-alone model 520 for rack installation” on page 106.

To install the system into a rack, complete the following steps:

CAUTION:

Installing the rails in the rack is a complex procedure. To install the rails correctly, you must perform each task in the following order. Failure to do so might cause rail failure and potential danger to yourself and the system unit.

1. Read the "Rack Safety Notices" on page 1. Failure to read these notices could cause damage to the equipment or injury to the installer.
2. Complete a parts inventory (See Complete a parts inventory).
3. Locate the rack-mounting template **A**, the rack-mounting hardware kit **B**, and the system rail assemblies **C** that were included with your system unit as shown in Figure 106

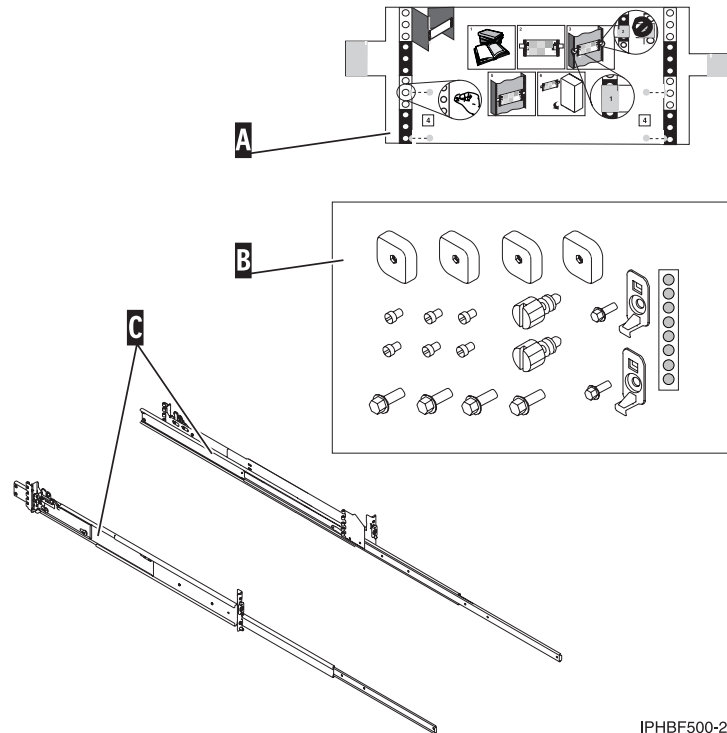

IPHBF500-2

Figure 106. Rack-mounting kit.

The system rails **D** and **E** are front-to-back and left-to-right side dependent as shown in Figure 107 on page 106. The rails are labeled "left" and "right" to indicate their placement when you face the front of the rack. There two large latch assemblies, **G** are located at the back of each rail. These latch assemblies go in the back of the rack.

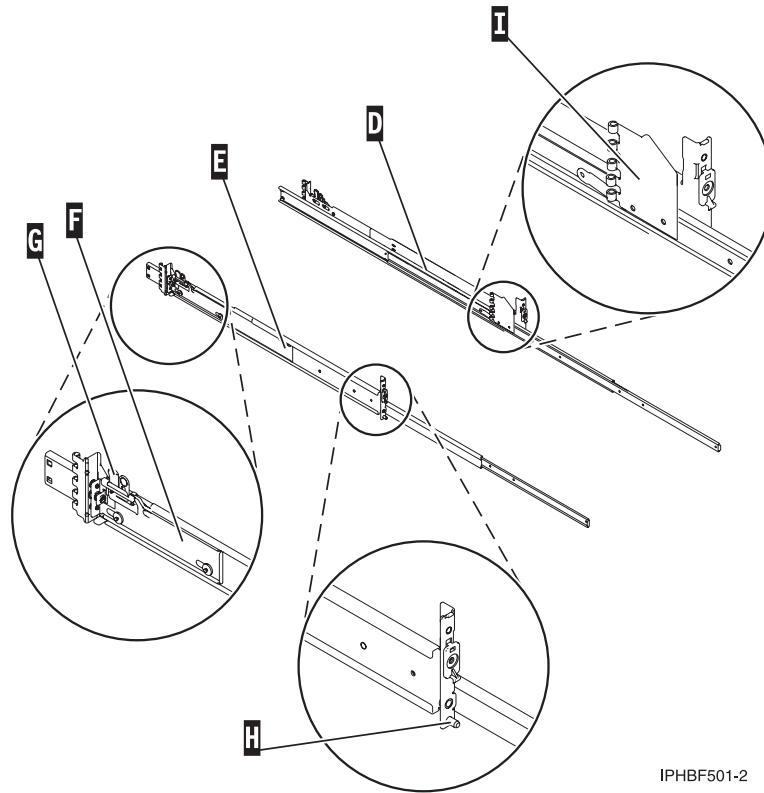

IPHBF501-2

Figure 107. System rails.

4. Determine where you will locate the expansion unit in the rack. See “Determining the location” on page 111. This system unit is 4 EIA units high.
5. Mark the location. See “Marking the location using a rack-mounting template” on page 112. If you do not have the rack-mounting template, see “Marking the location without a rack-mounting template” on page 114.

Converting the stand-alone model 520 for rack installation

You might need to convert the stand-alone model for rack installation. Use the procedure in this section to perform this task.

These procedures describe how to convert the stand-alone model feature code 7885 to a rack-installable model feature code 7884.

This feature is customer installable. However, the installation of this feature is intended for an experienced user who understands industry terminology.

Attention: After you have converted the stand-alone model, three people are needed to safely lift the unit into the rack.

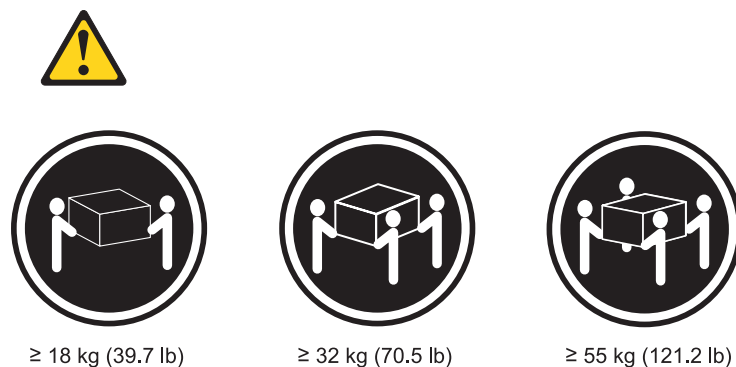

IPHBF442-0

When you use these instructions, you will perform some or all of the following tasks:

- Perform prerequisite tasks.
- Remove the system unit covers.
- Install new hardware.
- Install covers.
- Reconnect power cords and cables.
- Perform an IPL your operating system.
- Verify your new hardware configuration.

You can perform these tasks yourself or a contact service provider to perform these tasks. You might be charged a fee by the service provider for this service.

Note: If you have additional hardware to install in this server, complete and test this conversion and installation before installing new hardware.

Next topic: “Preparing the stand-alone 52x”

Preparing the stand-alone 52x:

You might need to prepare the stand-alone system to be converted to a rack-mounted system. Use the procedure in this section to perform this task.

To prepare the stand-alone system, complete the following procedure:

1. Read the “Rack Safety Notices” on page 1. Failure to read these notices could cause damage to the equipment or injury to the installer.
2. Perform the prerequisite tasks described in Before beginning.
3. Complete a parts inventory. See Complete a parts inventory. The kit for converting a stand-alone unit to a rack-mounted unit includes:
 - Left and right rails
 - Cable-management arm
 - Left and right rack release latches
 - Rack-mounting template
 - Screws
 - Handles
 - Top cover and front cover

- Brackets

4. Stop the system if it is running. See Stop the system.
5. Shut down and disconnect the Hardware Management Console (HMC), if an HMC is connected to this system unit. See Managing the Hardware Management Console (HMC).

Note: If the HMC is powered off or disconnected from a nonpartitioned managed system for a period of 14 days, the managed system will no longer recognize the HMC. If this situation occurs and the managed system fails to recognize the HMC, you will need to set up the HMC again.

6. Disconnect and label the cables, and unplug the power source.
7. Remove the service access cover. See Remove the service access cover.
8. Remove the front door. See Remove the door.
9. Remove the front cover. See Remove the front cover.
10. Remove the control panel cover.
 - a. Remove two screws **A** that are inset to the left and right of the front of the control panel as shown in the following figure.
 - b. Lift the cover **B** up and away from the control panel.

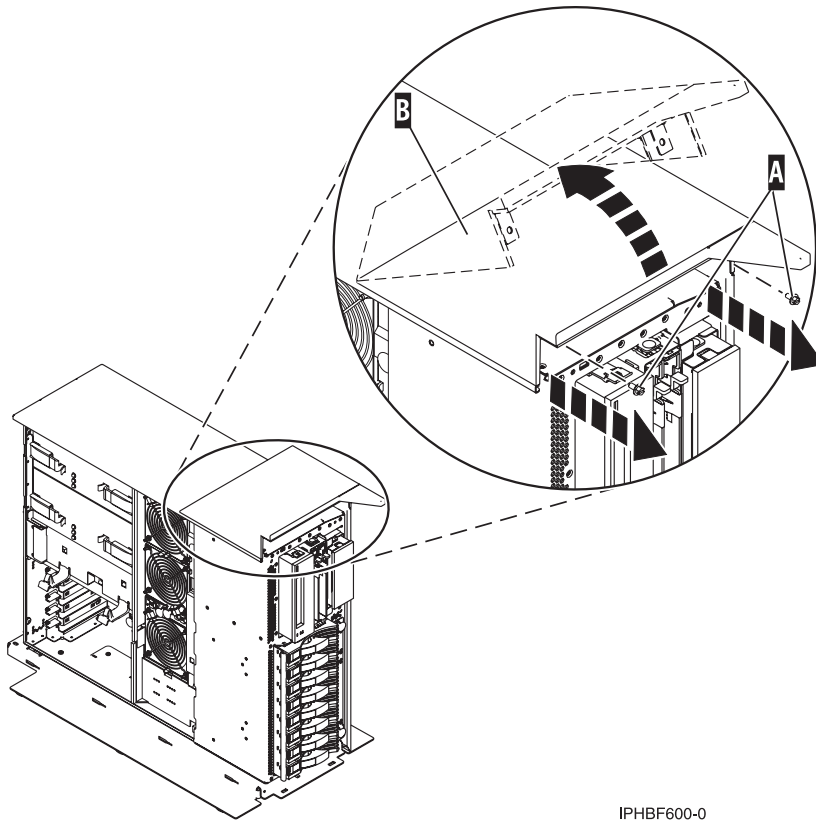

IPHBF600-0

Figure 108. Removing the control panel cover.

11. Remove the wraparound cover.
 - a. Remove two screws securing the control panel enclosure to the chassis, Figure 109 on page 109, C.

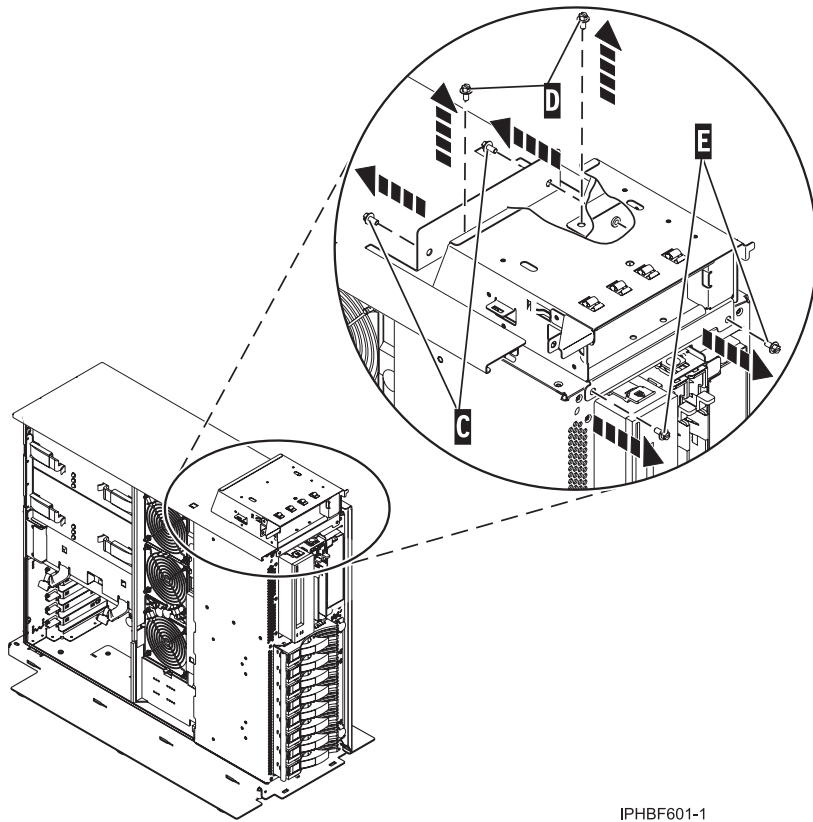

IPHBF601-1

Figure 109. Removing the control panel screws.

- b. Slide the cover **F** toward the back of the unit and lift it away from the unit as shown in the next figure.

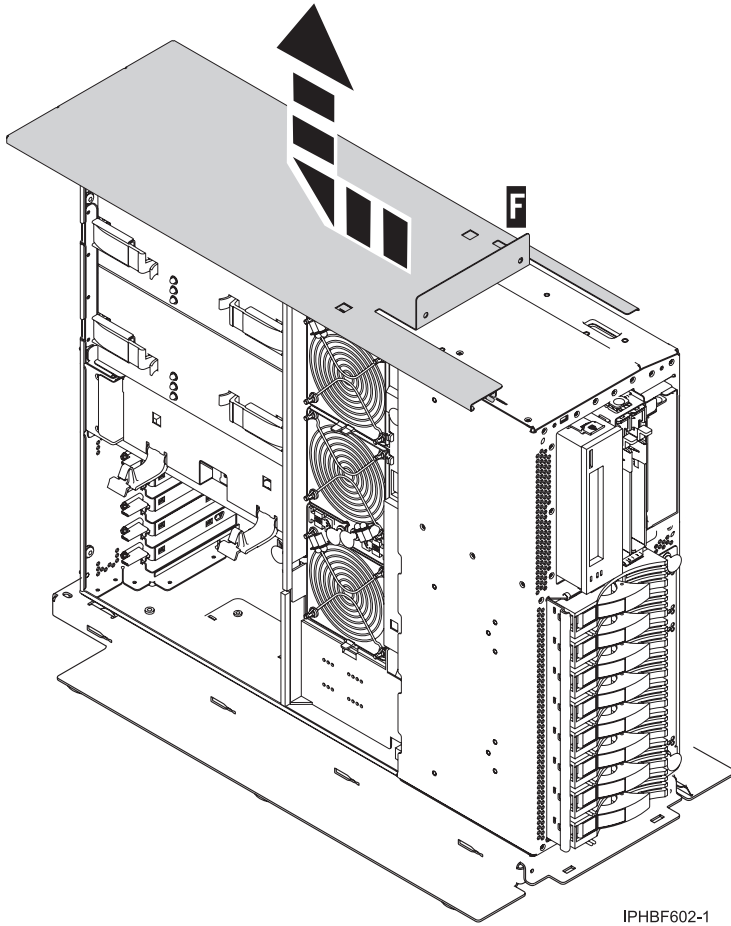

IPHBF602-1

Figure 110. Sliding the cover.

12. Remove the control panel. See Remove the control panel with power off.
13. Remove the top control panel enclosure.
 - a. Remove the screws connecting the control panel enclosure to the system unit, as shown in Figure 109 on page 109, **D** and **E**.
 - b. Lift the control panel enclosure.
 - c. Thread the control panel cable through the control panel enclosure.
 - d. Remove the control panel enclosure.
14. Remove the control panel filler (next to the media devices). See Remove the control panel filler.
15. Route the control panel cable from the top of the system unit into the slot in the open control panel enclosure.
16. Install the control panel. See Replace the control panel.
17. Carefully place the system unit down with the open side facing up.
18. Remove the four screws from the bottom to remove the base.
19. Install the service access cover (included in the conversion kit). See Installing the service access cover.
20. Attach the handles (included the conversion kit) to the sides of the chassis.
 - a. Put the handle in the handle bracket.
 - b. Position the handle as shown in Figure 111 on page 111, **G**.
 - c. Use two screws to attach the each handle **G** to the chassis.

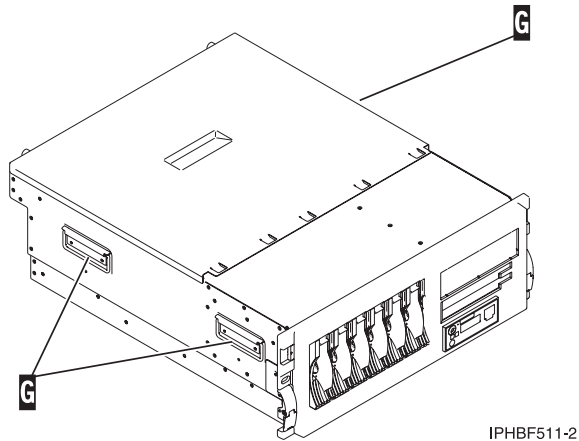

Figure 111. Attaching the handles.

The unit is now ready to install into the rack.

21. Follow the steps for attaching the mounting hardware to the rack and installing the system unit on the rail assembly in “Installing the 515 or 52x into a rack” on page 104. Return to these procedures.
22. Install the cable-management arm and return to these procedures. See “Installing the cable-management arm” on page 119.

Determining the location

You might need to determine where to install the system in the rack. This section includes procedures so that you can perform these tasks.

Before installing the system unit or expansion unit into a rack, complete the following steps:

1. Read the “Rack Safety Notices” on page 1.
2. Plan where you will place the units. Place the larger and heavier units in the lower part of the rack.
3. If the rack contains filler panels, remove the filler panels to allow access to the inside of the rack enclosure where you plan to place the unit.

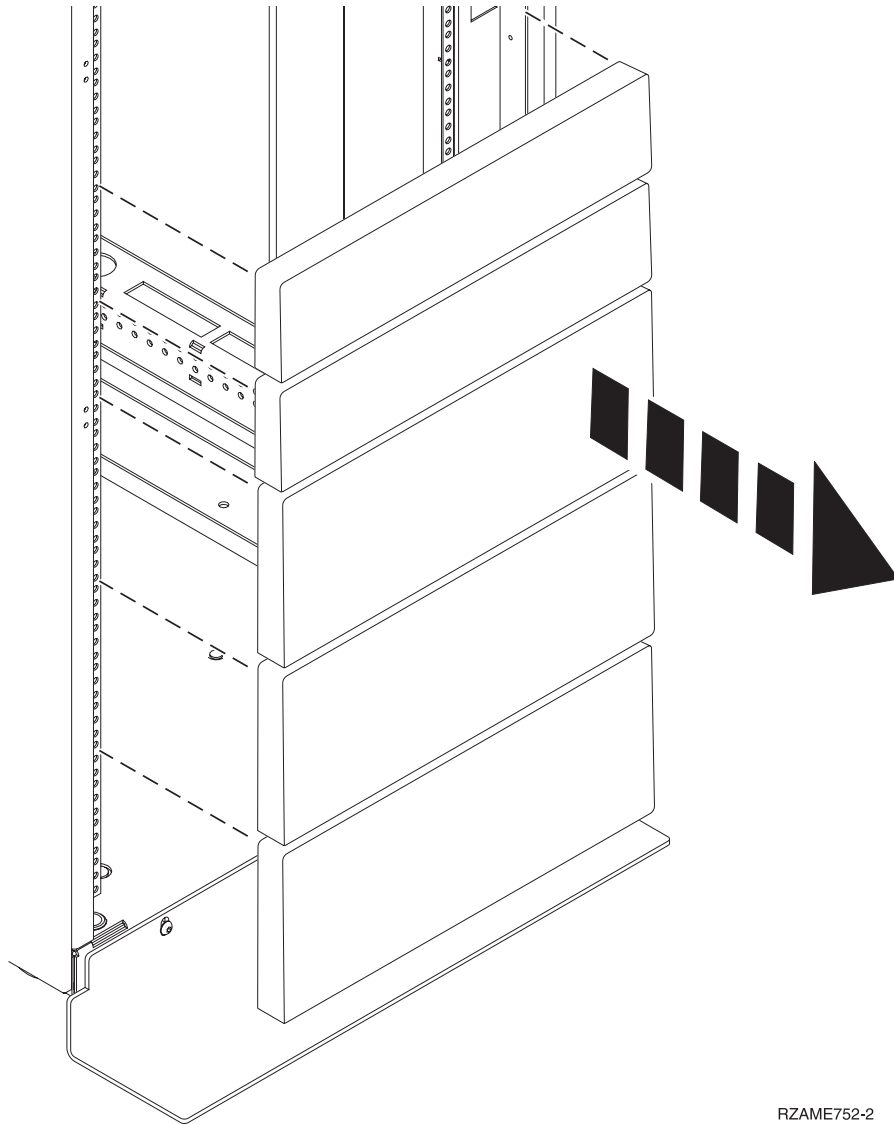

RZAME752-2

Figure 112. Removing the filler panels.

4. Remove the front and back rack doors if necessary.
5. Follow the instructions for either Marking the location without a rack-mounting template or “Marking the location using a rack-mounting template.”

Marking the location using a rack-mounting template:

You might need to mark the installation location using a rack-mounting template. Use the procedure in this section to perform this task.

1. Using the rack-mounting template, determine where in the rack to place the system unit. Install units in the lower part of the rack first. Place larger and heavier units in the lower part of the rack.

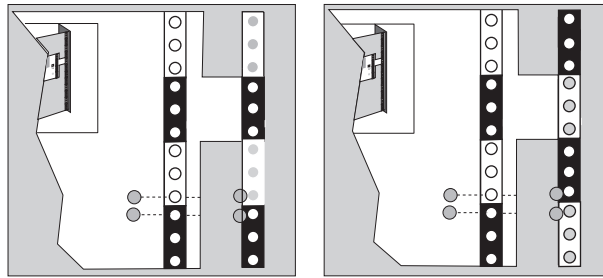

IPHBF502-0

Figure 113. Rack-mounting template.

Note: The front of the rack-mounting template has printed illustrations designed to help you identify the EIA location holes to be used when you add units to the rack. *Do not* use the rack-mounting template without completing the following steps.

2. Note the following when using the rack-mounting template:
 - Each black or white unit on the template is equal to 1 EIA unit.
 - Each EIA unit consists of three holes.
 - The EIA units illustrated on the template must be aligned with the EIA units located on the rack.
 - It is not necessary to align like-colored EIA units. For example, a black EIA unit on the rack-mounting template can be aligned with a white EIA unit located on the rack.
 - The template is two-sided. When using the template, ensure that the appropriate side of the template is facing out.

Figure 114 shows one EIA unit and four EIA units. Depending on the rack manufacturer, the EIA units might be separated either by color or by a line. Notice that the holes along the rail are not evenly spaced. If your rack has no color or line separation between EIA units, assume that each EIA unit begins where the hole spacing **A** is closest together.

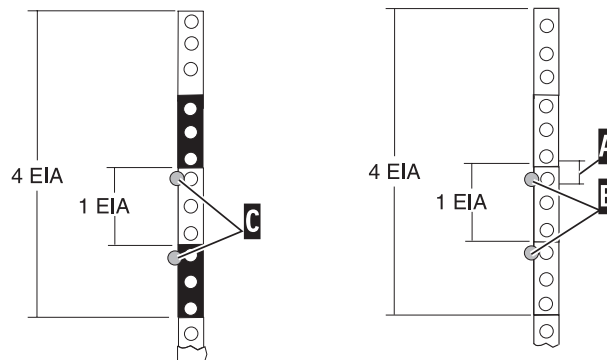

IPHBF503-0

Figure 114. EIA units.

To use the rack-mounting template, complete following steps:

- a. Remove the protective coating from each adhesive strip located on the back of the rack-mounting template. Lightly press the template into position on the rack. Ensure that both the left and right sides are at the corresponding EIA locations.

Note: The tabs on each side of the template show a notch to indicate the correct spacing between the front flanges.

- b. Locate the dots, printed on the left and right side of the template. Place a self-adhesive dot directly across from the template's printed dots on or near the rack's EIA numbering strip. You will be using these dots to aid in correctly positioning the rail-alignment pins located on the front of each rail.
- c. Remove the rack-mounting template from the front of the rack. The front of your rack should now contain dots.
- d. Mount the rack-mounting template to the rack's back EIA frame. Place the rack-mounting template at the same EIA-numbered location that was used on the front of the rack.
- e. Wrap a self-adhesive dot directly across from the template's printed dots. Ensure that a portion of the self-adhesive dot wraps around the rack frame so that it can be seen from the front of the rack.
- f. Remove the rack-mounting template from the back of the rack. The back of your rack should now contain dots that have been partially wrapped around the frame.

Marking the location without a rack-mounting template:

You might need to mark the location without a template. Use the procedure in this section to perform this task.

If you do not have a rack-mounting template, complete the following steps:

1. Determine where in the rack to place the system. Record the EIA location.

Note: An EIA unit on your rack consists of a grouping of three holes.

2. Facing the front of the rack and working from the right side, place a supplied self-adhesive dot next to the top hole of the EIA unit.

Note: The self-adhesive dots are used to aid in identifying locations on the rack. If you no longer have any of the dots, use some other form of marking tool to aid you in identifying hole locations (for example, tape, a marker, or pencil).

3. Place another self-adhesive dot next to the bottom hole of the above EIA unit.

Note: If you are counting the holes, begin with the hole identified by the first dot and count up two holes. Place the second dot next to the third hole.

4. Repeat steps 1 through 4 for the corresponding holes located on the left side of the rack.
5. Go to the back of the rack.
6. On the right side, find the EIA unit that corresponds to the bottom EIA unit marked on the front of the rack.
7. Place a self-adhesive dot at the bottom EIA unit.
8. Place a self-adhesive dot at the top hole of the EIA unit.
9. Mark the corresponding holes on the left side of the rack.

Attaching the mounting hardware to the rack

You might need to attach the mounting hardware to the rack. Use the procedure in this section to perform this task.

To install the rack-mounting hardware into the rack, complete the following steps:

1. From the front of the rack, set the system rails to allow correct assembly with the rack and system unit. Refer to Figure 115 on page 115 and complete the following steps:
 - a. Fully extend each rail assembly, **D** and **E**.
 - b. Pull the back latch assembly release tab **G** to the retracted position and lock the latch assembly **F**. The back-alignment pins should be fully retracted.
 - c. Pull the front latch assembly release tab to the retracted position and lock the latch assembly. The front-alignment pin should be fully retracted.

Note: Although the rail installation can be completed by one person, it is recommended that one person hold the rail in place in the front position while another locks the latch assembly in place.

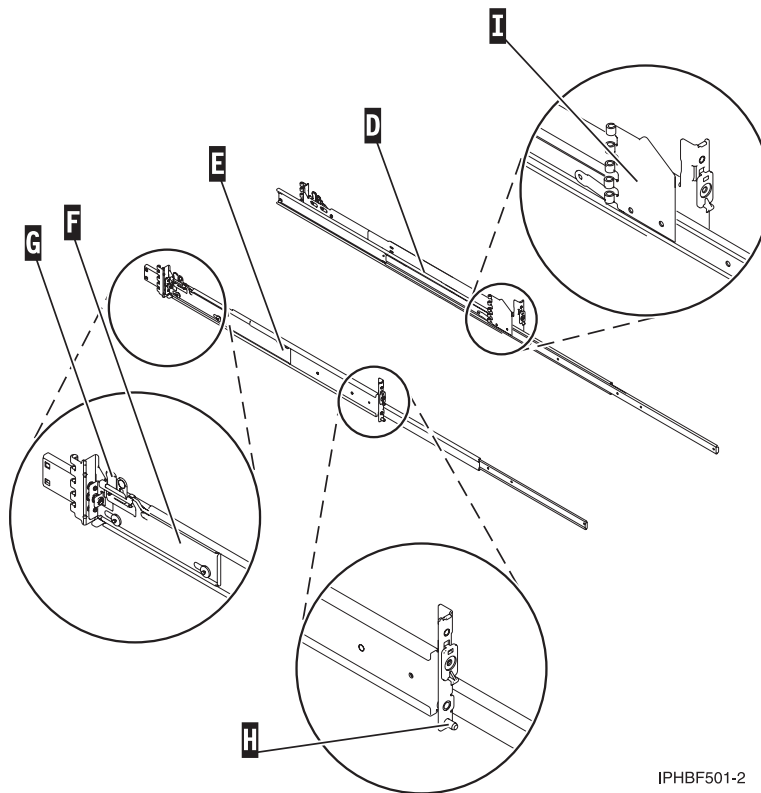

IPHBF501-2

Figure 115. Setting up the system rail assembly.

2. From the back of the rack, insert the front-alignment pin **H** (Figure 115) into the hole at the front of the rack identified by the self-adhesive placement dot that you previously installed. Have a second person hold the rail securely in the front hole.
3. Press the release tab **G** (Figure 115) to extend the front-alignment pin into the front of the rack. Ensure that the pin passes through the correct hole in the rack frame.
4. From the front of the rack, align the back-alignment pins, **H** and of the rail with the holes at the back of the rack identified by the self-adhesive placement dot that you previously installed. The back EIA location will be one position higher than the front rail position. Ensure that the rails are level.
5. Press the release tab **G** (Figure 115) to extend the two back-alignment pins into the back of the rack. Ensure that the pins have passed through the correct holes in the rack frame.
6. From the back of the rack, finger-tighten one of the rail-retaining screws into the hole that is located above the two back alignment pins.
7. From the front of the rack, finger-tighten one of the system-retaining screws **L** into the first hole position above the front-alignment pin **M** as shown in Figure 116 on page 116.
8. From the front of the rack, attach the system-unit latch bracket as follows:
 - a. Locate a system-unit latch bracket **J** and its screw.
 - b. Align the latch bracket **J** with the hole **K**. The top of the latch bracket hooks into the hole above.
 - c. Finger-tighten the screw into place.

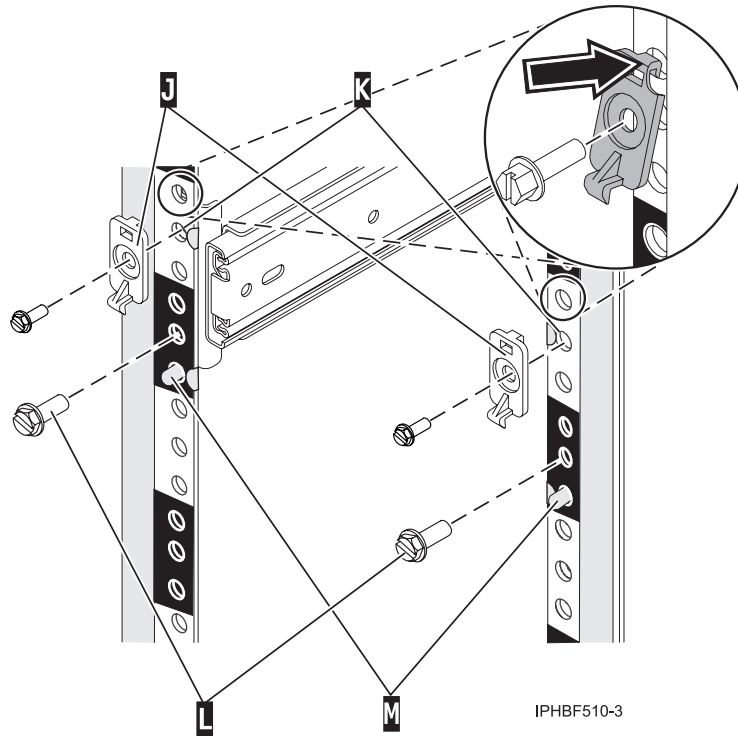

Figure 116. Securing the system rails to the front of the rack.

9. Repeat steps 2 on page 115 through 8c on page 115 for the rail assembly on the other side of the rack.

Installing the system unit onto the rail assembly

You might need to install the system into a rack. Use the procedure in this section to perform this task.

Before installing the system onto the rail assembly, ensure that the stabilizers are extended and the tip plate is attached to the bottom front of the rack to prevent the rack from falling forward when the rails are pulled out of the rack. Refer to Install a rack.

To install the system unit onto the rail assembly, complete the following steps:

1. Attach the four knobs **B** to the system unit as shown in Figure 117.

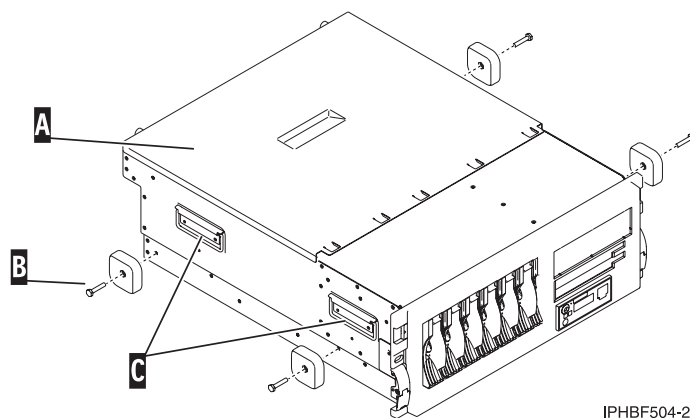

Figure 117. Attach knobs to system unit.

2. Fully extend both rails.

- Using three people, grasp the handles **C** located on each side of the system unit, and position the system unit on the extended rails as shown in Figure 118. Align the three holes in the inner rails with the holes in the sides of the system unit.

CAUTION:

This unit weighs between 32 kg (70.5 pounds) and 55 kg (121.2 pounds). Three people are required to safely move it. Using fewer than three people to move it can result in injury.

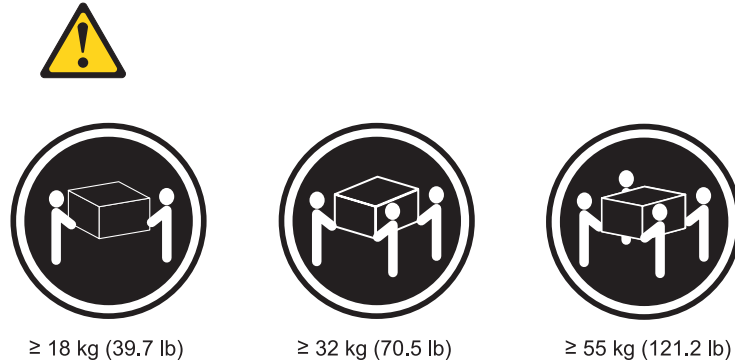

IPHBF442-0

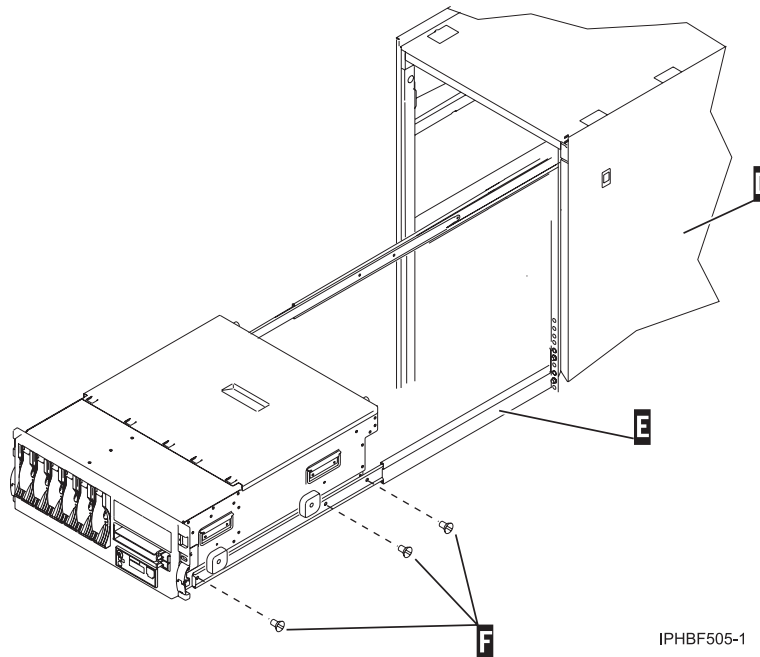

IPHBF505-1

Figure 118. Attaching the rails to system.

- Attach the rails **E** to each side of the system unit by using the system-to-rail screws **F**. Tighten each of the screws with a screwdriver or similar tool.
- Remove the four knobs, **B**.
- Simultaneously release the blue safety latches, **G**, located near the front of each system rail assembly, and push the system unit into the rack as shown in Figure 119 on page 118.

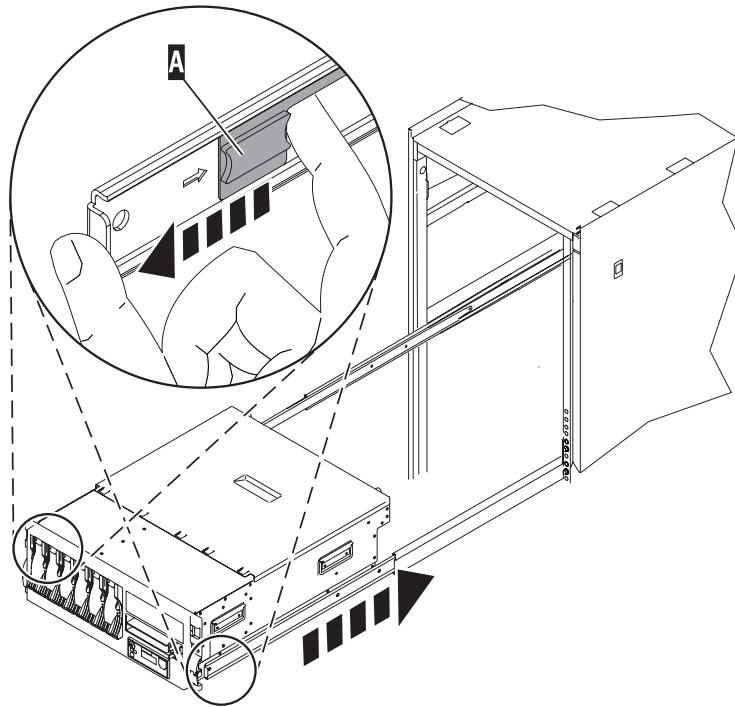

IPHBF509-1

Figure 119. Release the safety latches.

7. Slide the system unit into and out of the rack two or three times to align the system unit to the rails. The system unit should glide on the rails.
8. Push the system unit into the rack. Using a screwdriver or similar tool, tighten the two retaining screws that secure the slide rails to the back of the rack.
9. Slide the system unit halfway out of the rack.
10. Using a screwdriver or similar tool, tighten the front four retaining screws that secure the slide rails to the frame of the rack.

Note: After the system rails are installed, do not extend them past their safety latches. The safety latches prevent the rails from overextending and separating, thereby preventing the system unit from being pulled out too far and being dropped.

11. Slide the system unit into the rack.

Attention: If it does not slide smoothly, loosen the six rail-retaining screws (front and back), and repeat steps 6 on page 117 through 11.
12. Install the service access cover. Refer to Replace the front cover.
13. Install the rack latch brackets. Refer to “Installing or removing a rack-mounted system-unit latch bracket” on page 67.
14. To provide additional stability when transporting the rack, fasten the system unit to the rack by inserting the two system-retaining thumbscrews **I** through the front cover **H**, and screwing them into the rack frame as shown in Figure 120 on page 119.

Note: If you are installing the retaining thumbscrews, you will need to install the optional bezel on the front of the system.

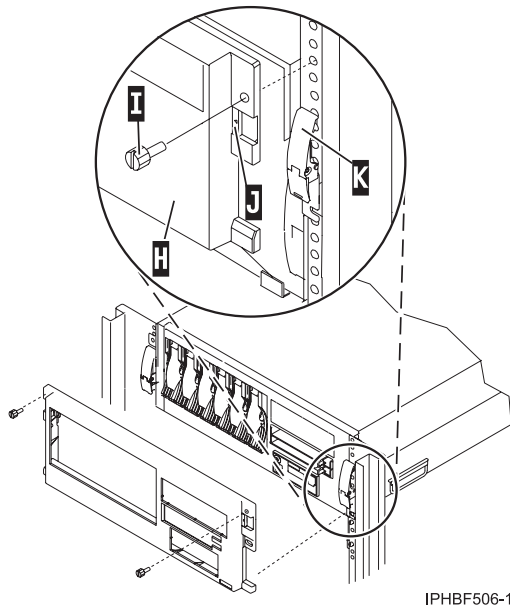

IPHBF506-1

Figure 120. Secure the system unit to the rack.

Installing the cable-management arm

You might need to install the cable-management arm. Use the procedure in this section to perform this task.

To install the cable-management arm, complete the following steps:

1. From the back of the rack, locate the cable-management arm flange **C** located on the fixed back portion of the left system rail assembly **B**.

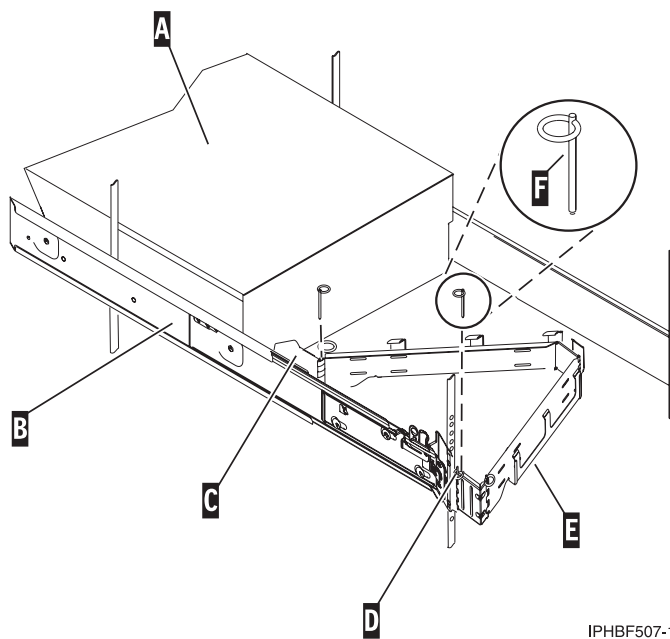

IPHBF507-1

Figure 121. Installing the cable-management arm.

2. Use pin **F** to pin the cable-management arm **E** to the rack frame **D**.

Note: If access to the back of the rack is obscured by a large number of existing cables, it might be easier to remove the small connecting hinge from the cable-management arm and attach it first. Then, you can attach the remaining section of the cable-management arm to the connecting hinge.

3. Use pin **F** to pin the other end of the cable-management arm to the flange **C** attached to the sliding portion of the left system rail assembly **B**.

Note: Ensure that the cable-management arm is level so that it moves freely.

Installing the model 55x, 9113-550, or OpenPower 720 in a rack

You might need to the system into a rack. Use the procedure in this section to perform this task.

This topic describes how to install the system in a rack. This is a customer task. You can perform this task yourself, or contact a service provider to perform the task for you. You might be charged a fee by the service provider for this service.

Note: To complete this procedure, it is suggested that you use two people to attach the rail assembly to the rack, one in front of the rack and one at the back of the rack. You will need three people to lift the system unit onto the rack.

This procedure assumes that you are installing the system into an existing rack. If the rack is not installed, go to the instructions for installing the rack and then return to this procedure for instructions on installing the system unit in a rack.

Note: This procedure applies only to the models that are designed to be mounted in a rack. Do not attempt to install a stand-alone model in a rack.

To install model 55x, 9113-550, or OpenPower® 720 in a rack, complete the following steps:

CAUTION:

Installing the rails in the rack is a complex procedure. To install the rails correctly, you must perform each task in the following order. Failure to do so might cause rail failure and potential danger to yourself and the system unit.

1. Read the “Rack Safety Notices” on page 1.
2. Complete a parts inventory, if you have not done so.

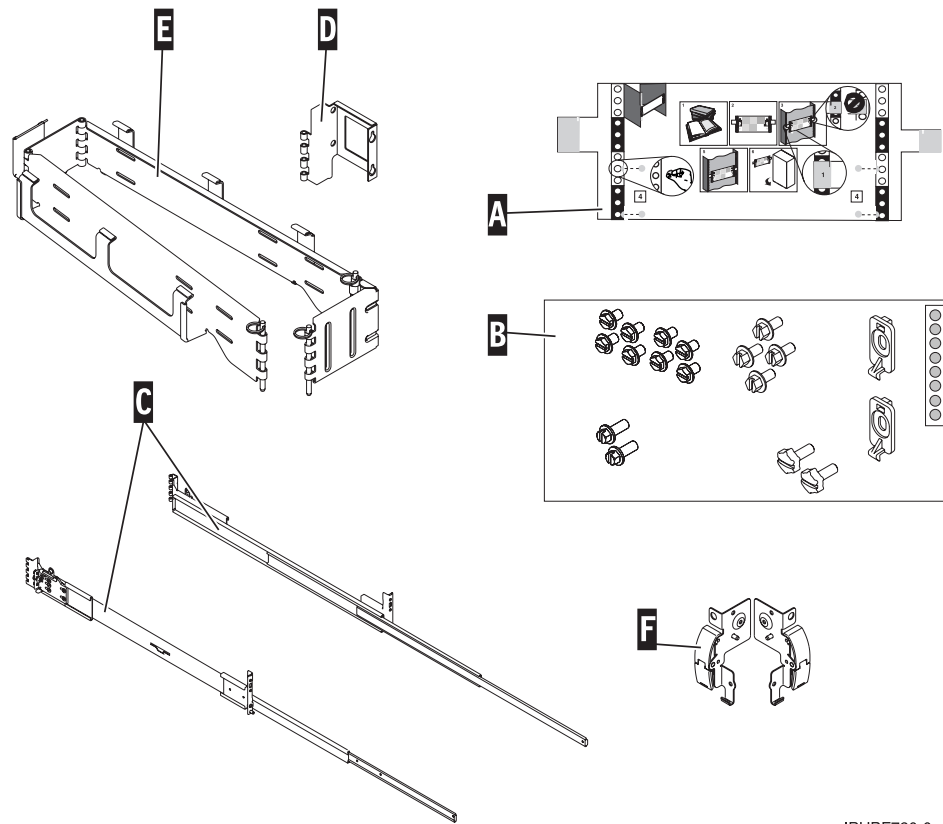

IPHBF720-0

Figure 122. Rack-mounting kit.

- A** Rack-mounting template
- B** Rack-mounting hardware kit
 - Four large retaining screws
 - Eight small retaining screws
 - Two blue thumbscrews
 - Two rack latch brackets
 - Two rack-latch bracket screws
 - Self-adhesive placement dots (these may be included on the rack-mounted template or on a separate sheet)
- C** Left and right rack rails with rack brackets
- D** Cable-management arm bracket
- E** Cable-management arm
- F** Two rack latches

If there are incorrect, missing or damaged parts contact:

- Your IBM reseller
 - IBM Rochester Manufacturing Automated Information Line at 1-800-300-8751 (United States only)
 - <http://www.ibm.com/planetwide>: Locate your service and support telephone numbers
3. Locate the rack-mounting template **A**, the rack-mounting hardware kit **B**, and the system rail assemblies **C** that were included with your system unit as shown in Figure 122.

The system rails C are front-to-back and left-to-right side dependent. The rails are labeled left and right to indicate their placement when you face the front of the rack. There two large latch assemblies at the back of each rail. These latch assemblies go in the back of the rack.

4. Determine where you will locate the system unit in the rack. See Determine the location.

Determining the location

You might need to determine where to install the system in the rack. This section includes procedures so that you can perform these tasks.

Before installing the system unit into a rack, complete the following steps:

1. Read the “Rack Safety Notices” on page 1.
2. Plan where you will place the units. Place the larger and heavier units in the lower part of the rack. This system unit is four EIA units high.
3. If necessary, remove the filler panels to allow access to the inside of the rack enclosure where you plan to place the unit.

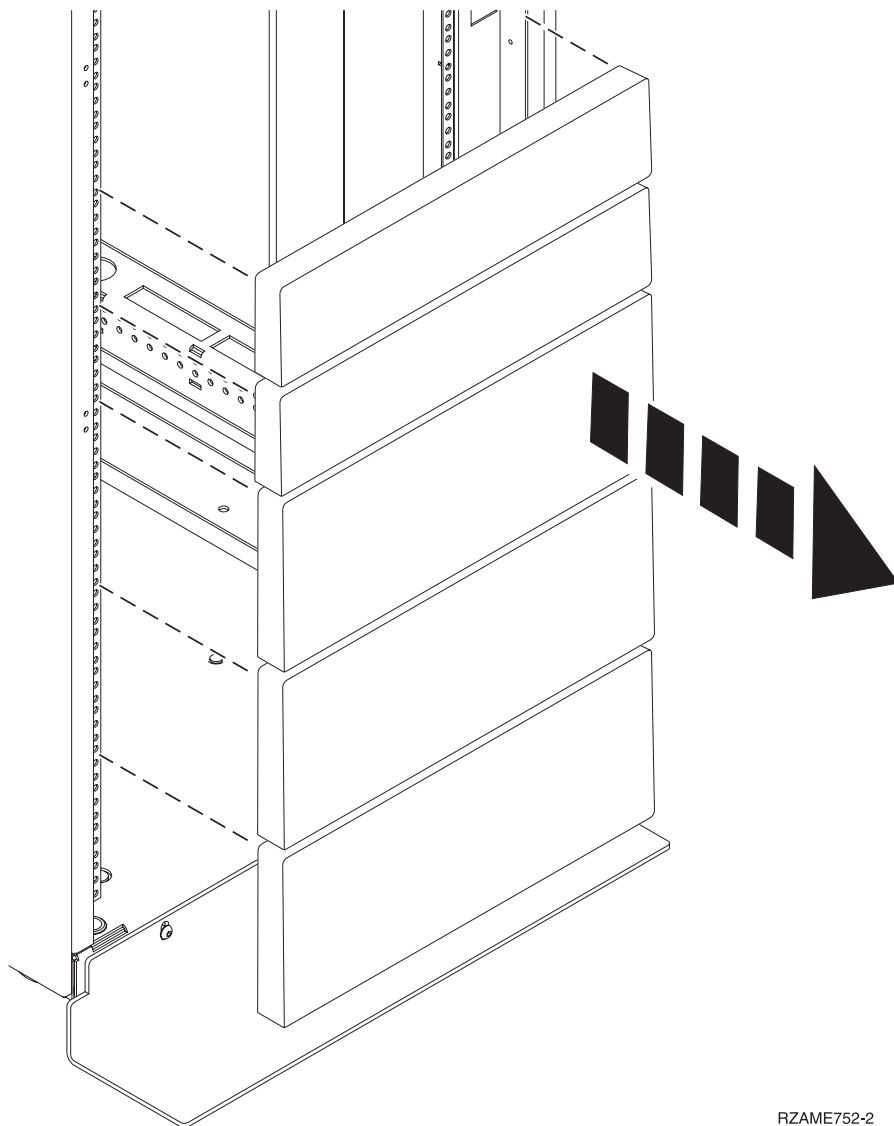

Figure 123. Removing the filler panels.

4. If necessary, remove the front and back rack doors.
5. Use the rack-mounting template to mark the location (see Mark location using the rack-mounting template). If you do not have a rack-mounting template, following instructions for marking the location without a template (see Mark the location without rack-mounting template).

Marking location using the rack-mounting template:

You might need to mark the installation location using a rack-mounting template. Use the procedure in this section to perform this task.

1. Using the rack-mounting template, determine where in the rack to place the system unit. Install units in the lower part of the rack first. Place larger and heavier units in the lower part of the rack.

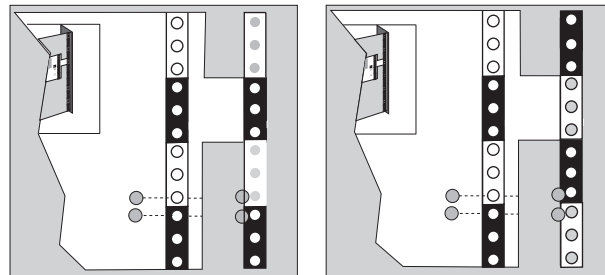

IPHBF502-0

Figure 124. Rack-mounting template.

Note: The front of the rack-mounting template has printed illustrations designed to help you identify the EIA location holes to be used when you add units to the rack. *Do not* use the rack-mounting template without completing the following steps.

2. Note the following when using the rack-mounting template:
 - Each black or white unit on the template is equal to one EIA unit.
 - Each EIA unit consists of three holes.
 - The EIA units illustrated on the template must be aligned with the EIA units located on the rack.
 - It is not necessary to align like-colored EIA units. For example, a black EIA unit on the rack-mounting template can be aligned with a white EIA unit located on the rack.
 - The template is two-sided. When using the template, ensure that the appropriate side of the template is facing out.

Figure 125 on page 124 shows one EIA unit and four EIA units. Depending on the rack manufacturer, the EIA units might be separated either by color or by a line. Notice that the holes along the rail are not evenly spaced. If your rack has no color or line separation between EIA units, assume that each EIA unit begins where the hole spacing is closest together as shown, **A** in Figure 125 on page 124.

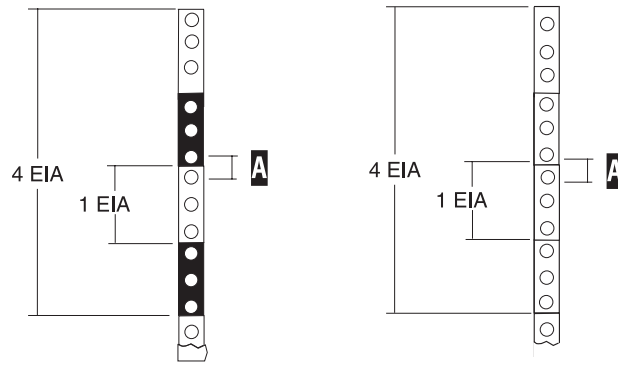

IPHBF721-0

Figure 125. EIA units.

To use the rack-mounting template, complete the following steps:

- a. Remove the protective coating from each adhesive strip located on the back of the rack-mounting template. Lightly press the template into position on the rack. Ensure that both the left and right sides are at the corresponding EIA locations.

Note: The tabs on each side of the template show a notch to indicate the correct spacing between the front flanges.

- b. Locate the dots, printed on the left and right side of the template. Place a self-adhesive dot directly across from the template's printed dots on or near the rack's EIA numbering strip. You will be using these dots to aid in correctly positioning the rail-alignment pins located on the front of each rail.
- c. Remove the rack-mounting template from the front of the rack. The front of your rack should now contain dots.
- d. Mount the rack-mounting template to the rack's back EIA frame. Place the rack-mounting template at the same EIA-numbered location that was used on the front of the rack.
- e. Wrap a self-adhesive dot directly across from the template's printed dots. Ensure that a portion of the self-adhesive dot wraps around the rack frame so that it can be seen from the front of the rack.
- f. Remove the rack-mounting template from the back of the rack. The back of your rack should now contain dots that have been partially wrapped around the frame.

Marking the location without a rack-mounting template:

You might need to mark the location without a template. Use the procedure in this section to perform this task.

If you do not have a rack-mounting template, complete the following steps:

1. Determine where in the rack to place the system. Install units in the lower part of the rack first. Place larger and heavier units in the lower part of the rack. Record the EIA location.
 - Each EIA unit consists of three holes.
 - These systems are four EIA units high.
2. Facing the front of the rack and working from the right side, place a self-adhesive dot next to the bottom hole of the bottom EIA unit of the four you will be using for this system unit A in Figure 126 on page 125.

Note: The self-adhesive dots are used to aid in identifying locations on the rack. If do not have the dots, use some other form of marking tool to aid you in identifying hole locations (for example, tape, or a marker). You will need to identify the marked hole from both the front and back of the rack.

3. Place another self-adhesive dot next to the bottom hole of the bottom EIA unit on the left side of the rack.
4. Go to the back of the rack. On the right side, find the EIA unit that corresponds to the bottom EIA unit marked on the front of the rack.

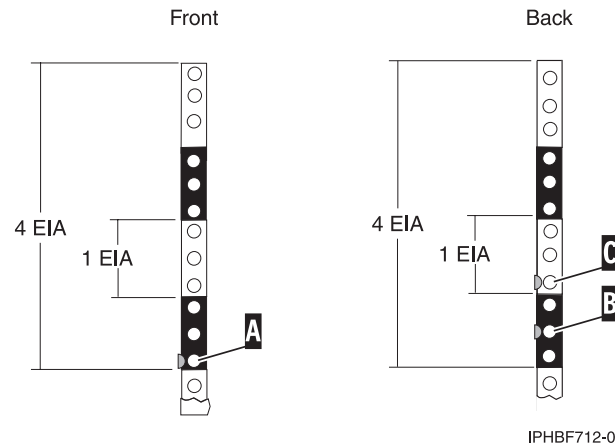

Figure 126. Marking holes on the front and back of the rack frame.

5. Place a self-adhesive dot at the middle hole of the bottom EIA unit, **B** in Figure 126.
6. Place a self-adhesive dot at the bottom hole of the next (above) EIA unit, **C** in Figure 126.
7. Mark the corresponding holes on the left side of the rack.

Attaching the mounting hardware to the rack

You might need to attach the mounting hardware to the rack. Use the procedure in this section to perform this task.

Attention: Installing the rails in the rack is a complex procedure. To install the rails correctly, you must perform each task in the following order. Failure to do so might cause rail failure and potential danger to yourself and the system unit.

To install the rack-mounting hardware into the rack, complete the following steps:

1. Beginning with the right slide rail, remove the right inner rail, **A** in Figure 127 on page 126. To do this, complete the following substeps:
 - a. Extend the rail.
 - b. Press the blue release button, **B** in Figure 127 on page 126, to release the inner rail.
 - c. Remove the inner rail.
 - d. Repeat the preceding steps for the left slide rail.

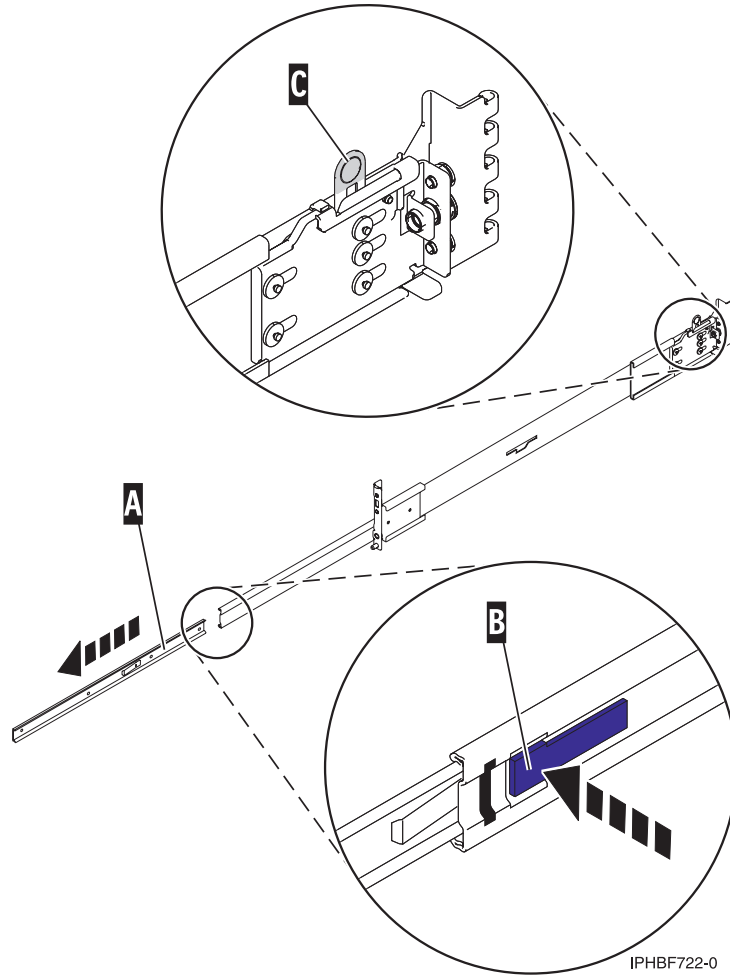

Figure 127. Removing the inner rail from the rail assembly.

2. Pull the back latch assembly release tab, **C** in Figure 127, to the retracted position and lock the latch assembly. The back-alignment pins should be fully retracted.
3. Insert the right side rail's front-alignment pin, **D** in Figure 128 on page 127, into the rack front flange hole identified by the self-adhesive placement dot that you previously installed. Have a second person hold the rail securely in the front hole.

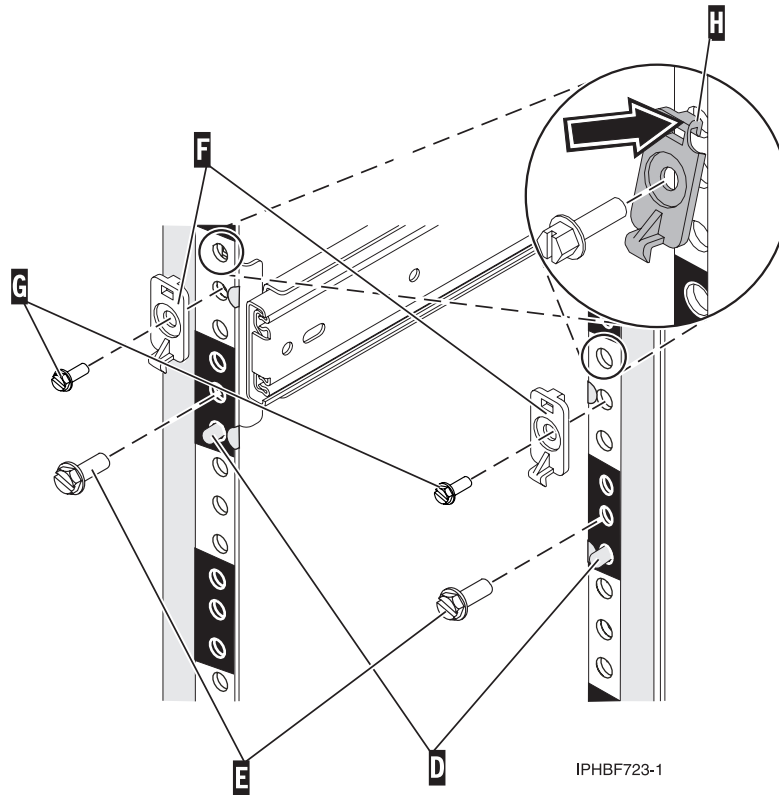

Figure 128. Front slide rail alignment pin, retaining screws, and latch bracket.

4. Align the back-alignment pins of the rail with the holes at the back of the rack identified by the self-adhesive placement dots on the back of the rack. The back EIA location will be one position higher than the front rail position. Ensure that the rails are level.
5. Press the release tab, C in Figure 127 on page 126, outward to extend the two back-alignment pins into the back of the rack. Ensure that the pins have passed through the correct holes in the rack frame.
6. From the back of the rack, insert one of the large rail-retaining screws into the hole that is located between the two back alignment pins. Partially tighten the screw. Do not tighten completely at this time.
7. From the front of the rack, finger-tighten one of the large rail-retaining screws into the hole that is located above the front alignment pin, E in Figure 128.
8. Locate one of the latch brackets, F in Figure 128. Insert the tab at the top of the latch bracket into the rack as shown H.
9. Attach the latch bracket to the rack with a small rail-retaining screw G in Figure 128. Finger-tighten the screw.

Attention: Do not tighten any of the screws completely until instructed to do so. Tightening the screws prevents the rails from self-aligning when the system drawer is attached.
10. Repeat steps 2 on page 126 through 9 for the left side rail.
11. After both rails have been installed, ensure that none of the rail's retaining screws are more than finger-tight. The rails *must* be level from front to back and from left to right.

Installing the system unit on the rail assembly

You might need to install the system unit on the rail assembly. Use the procedure in this section to perform this task.

Before installing the system unit on the rail assembly, ensure that the stabilizers are extended and the tip plate is attached to the bottom front of the rack to prevent the rack from falling forward when the rails are pulled out of the rack. Refer to Install the rack.

To install the system unit on the rail assembly, complete the following steps:

1. Using the eight rail-to-system-unit retaining screws **A** in Figure 129, four on each side, mount the inner rails **B** to each side of the system drawer. Tighten each of the screws with a screwdriver or similar tool.

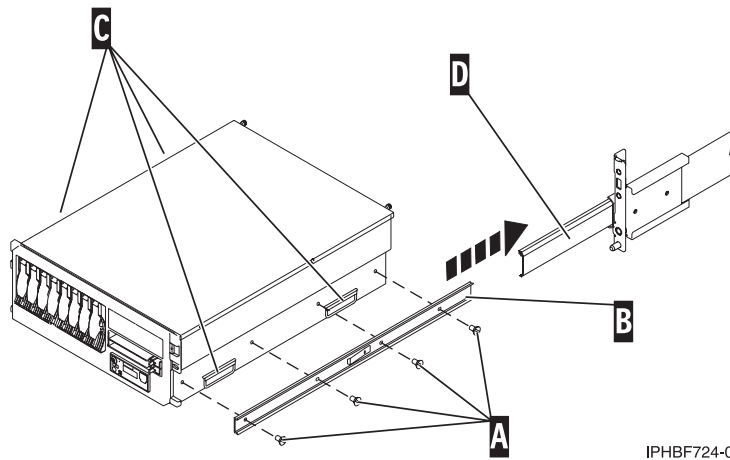
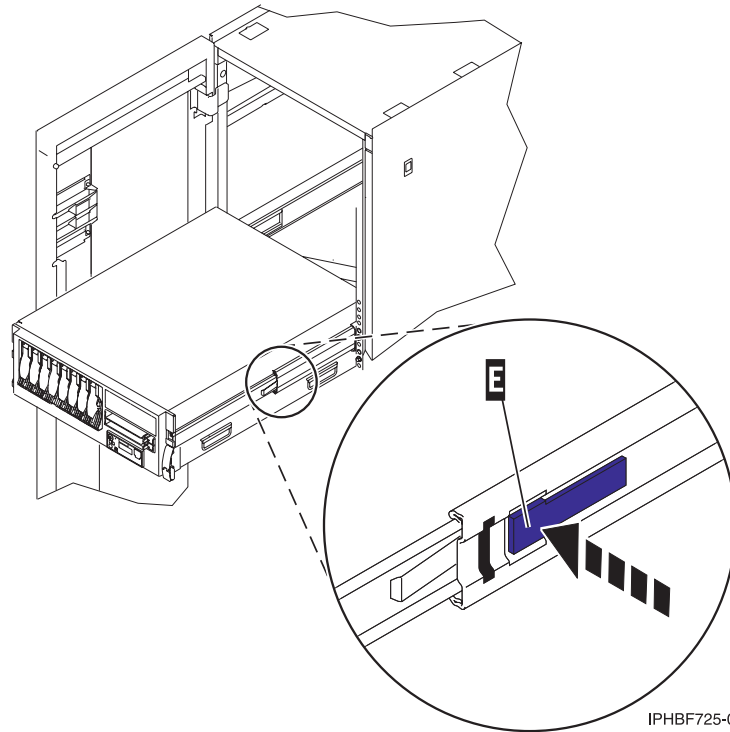

Figure 129. Attaching the system rails and slide the system unit onto the rail assembly.

2. Ensure that the rails on the rack are extended and latched.
3. Using three people, grasp the two handles located on each side of the system drawer, **C** in Figure 129, and lift the system drawer.
4. Insert the inner rails located on the system drawer **B** in Figure 129, into the rails mounted in the rack **D**.

Attention: When matching the inner rails to the outer rails, ensure that both rail faceplates glide past each other. *Do not*, under any circumstances, force the rails. If the system drawer does not glide freely into the rack, completely remove the drawer from the outer rails. After the drawer is clear of the outer rails, reposition the system, then reinsert the inner rails. Repeat this process until the system drawer glides freely into the rack.

5. Simultaneously press the safety latches, located on each side of the system drawer **E** in Figure 130 on page 129, and push the system unit into the rack.



IPHBF725-0

Figure 130. Press the safety latches and push the system unit into the rack.

6. Slide the system drawer in and out of the rack two or three times. This action aligns the system drawer to the rails. The system drawer should glide on the rails.
7. Push the system drawer back into the rack. Using a screwdriver or similar tool, tighten the rail-retaining screws that secure the slide rails to the rack's rear flange on each side of the rack.
8. Slide the system drawer about halfway out of the rack.
9. Using a screwdriver or similar tool, tighten the front rail-retaining screws that secure the slide rails to the rack's front flange on each side of the rack.

Note: After the system rails are installed, do not extend them past their safety latches. The safety release latches stop the rails from overextending and separating. This action prevents the system drawer from being accidentally pulled out too far and dropped.

Attention: If any binding is detected, loosen the rail-retaining screws (front and back), and repeat steps 5 on page 128 through 9.

10. When transporting the rack, fasten the system drawer to the rack enclosure by inserting a thumbscrew (transport retaining screw) through the bezel and chassis bracket, and screwing it to the rack flange as shown F in Figure 131 on page 130.

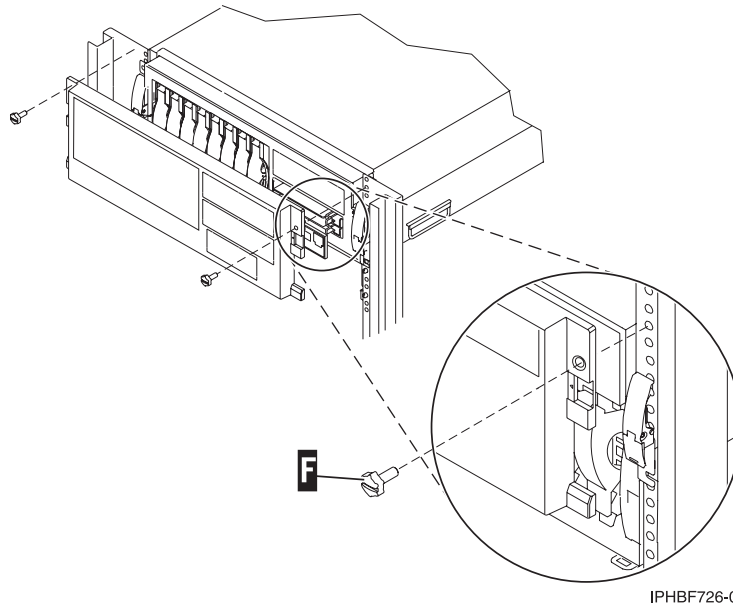

IPHBF726-0

Figure 131. Transport retaining screw.

Installing the cable-management arm

You might need to install the cable-management arm. Use the procedure in this section to perform this task.

To install the cable-management arm, complete the following steps:

1. From the back of the rack, use two screws **B** to attach the cable-management arm bracket **A** to the back left side of the server as shown in Figure 132.

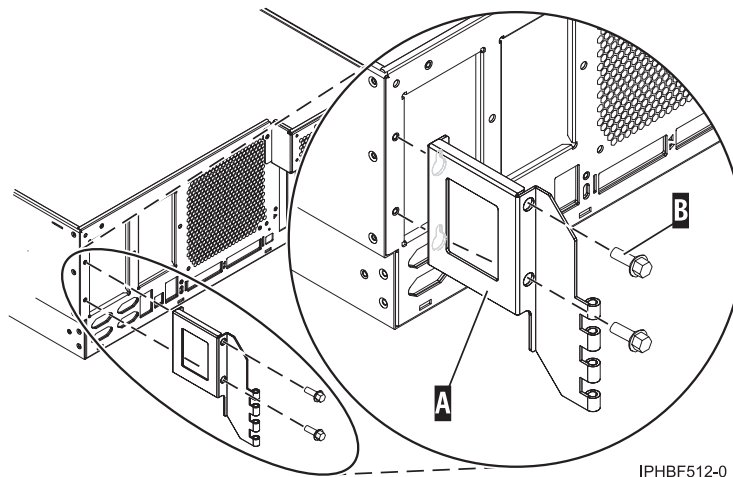

IPHBF512-0

Figure 132. Attaching the cable-management arm bracket to the back of the server.

2. Use pin **H** to pin the cable-management arm **G** to the rack frame **F** as shown in Figure 133 on page 131.

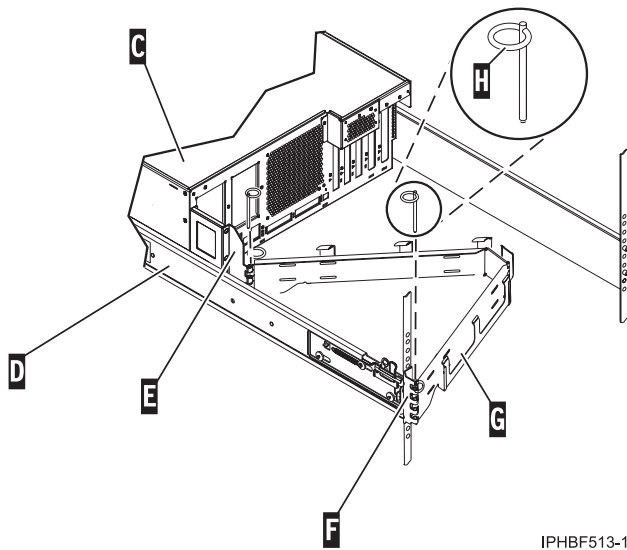

Figure 133. Attaching the cable-management arm.

Note: If access to the back of the rack is obscured by a large number of existing cables, it might be easier to remove the small connecting hinge from the cable-management arm and attach it first. Then, you can attach the remaining section of the cable-management arm to the connecting hinge.

3. Use the second pin **H** to pin the other end of the cable-management arm to the flange **E** attached to the sliding portion of the left system rail assembly **D** as shown in Figure 133.

Note: Ensure that the cable-management arm is level so that it moves freely.

Installing the model 7037-A50 into a rack

You might need to install the system into a rack. This section includes procedures so that you can perform these tasks.

You can perform this task yourself, or contact a service provider to perform the task for you. You might be charged a fee by the service provider for this service.

Note: To complete this procedure, it is easier if two people to attach the rail assembly to the rack with one person in front of the rack and one person at the back of the rack. Three people are needed to safely lift the system unit onto the rails in the rack.

This procedure assumes that you are installing the system into an existing rack. If the rack is not installed, go to the instructions for Installing the rack and then return to this procedure for instructions on installing the system unit in a rack.

Note: This procedure applies only to the models that are designed to be mounted in a rack. Do not attempt to install a stand-alone model in a rack.

To install system in a rack, complete the following steps:

Attention: Installing the rails in the rack is a complex procedure. To install the rails correctly, you must perform each task in the following order.

1. Read the “Rack Safety Notices” on page 1.
2. Complete a parts inventory, if you have not done so.

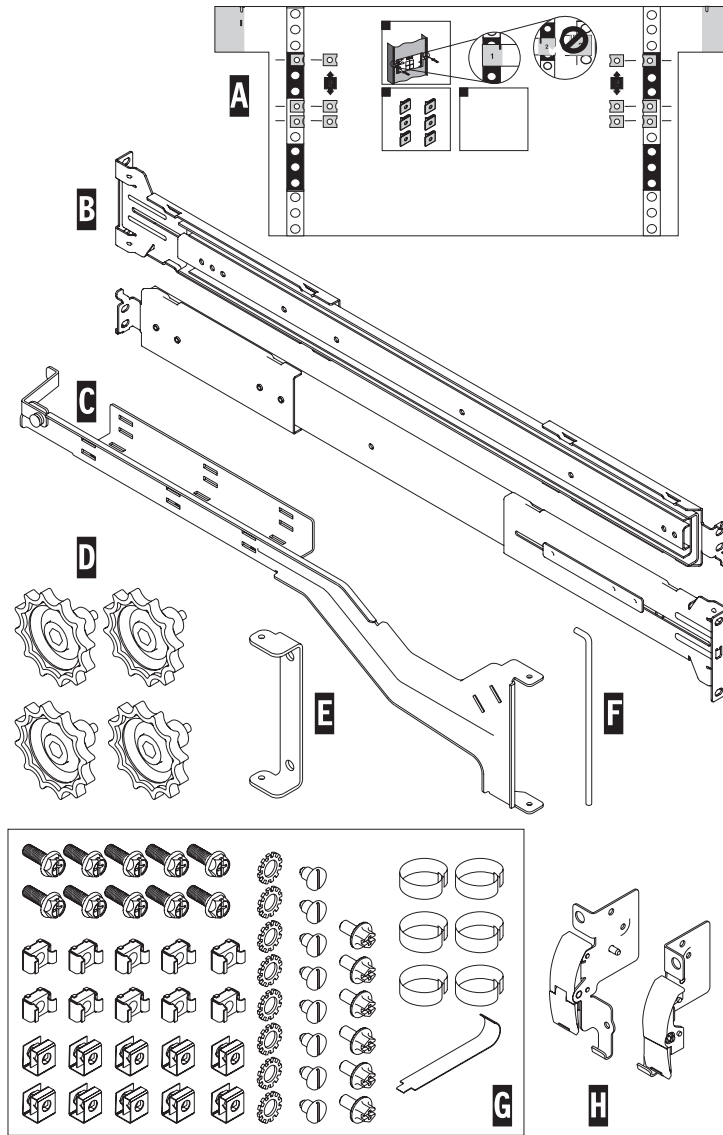

IPHBF815-3

Figure 134. Rack-mounting hardware.

- A (one) rack-mounting template
- B (two) rack rails
- C (one) cable management arm
- D (four) rack support wheels
- E (one) hinge bracket
- F (one) hinge pin
- G Rack-mounting hardware kit:
 - (ten) cable clamps
 - (ten) cage nuts
 - (ten) nut clips
 - (ten) M6 screws
 - (ten) M4 screws
 - (six) cable straps

- (one) cable-retainer bracket
- (one) cage nut insertion tool

H (two) rack latches (might be preinstalled on the system)

If there are incorrect, missing or damaged parts, contact:

- Your IBM reseller.
 - IBM Rochester Manufacturing Automated Information Line at 1-800-300-8751 (United States only).
 - <http://www.ibm.com/planetwide>: Locate your service and support telephone numbers.
3. Locate the rack-mounting template , the rack-mounting hardware kit, and the system rail assemblies that were included with your system unit as shown in Figure 134 on page 132
 4. Determine where you will locate the system unit in the rack. See Determining the location.

Determining the location

You might need to determine where to install the expansion unit in the rack. This section includes procedures so that you can perform these tasks.

Before installing the system unit into a rack, complete the following steps:

1. Read the “Rack Safety Notices” on page 1.
2. Plan where you will place the units. Place the larger and heavier units in the lower part of the rack. This system unit is five EIA units high.
3. If necessary, remove the filler panels to allow access to the inside of the rack enclosure where you plan to place the unit.

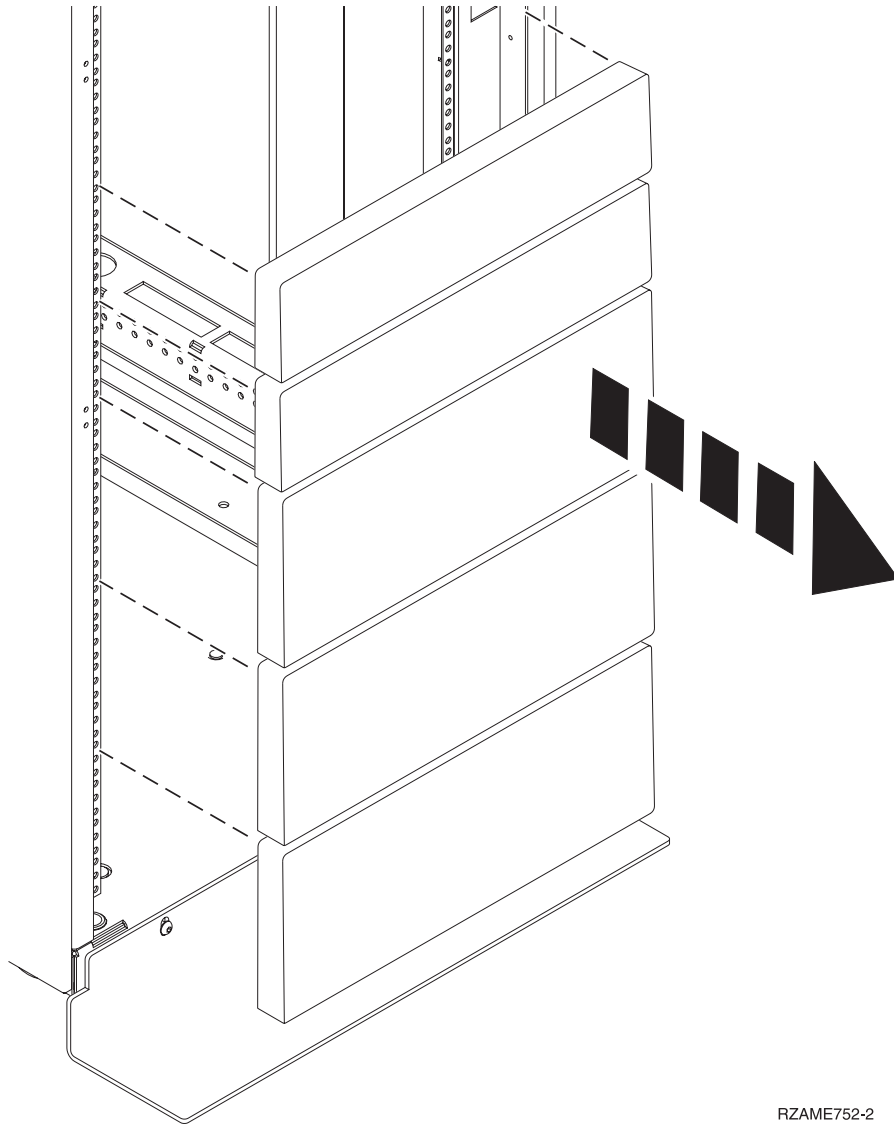

RZAME752-2

Figure 135. Removing the filler panels.

4. If necessary, remove the front and back rack doors.
5. Use the rack-mounting template to mark the location (see “Marking the location using the rack-mounting template”). If you do not have a rack-mounting template, following instructions for marking the location without a template (see “Marking the location without a rack-mounting template” on page 136).

Marking the location using the rack-mounting template:

You might need to mark the installation location using a rack-mounting template. Use the procedure in this section to perform this task.

1. Using the rack-mounting template, determine where in the rack to place the system unit. Install units in the lower part of the rack first. Place larger and heavier units in the lower part of the rack.

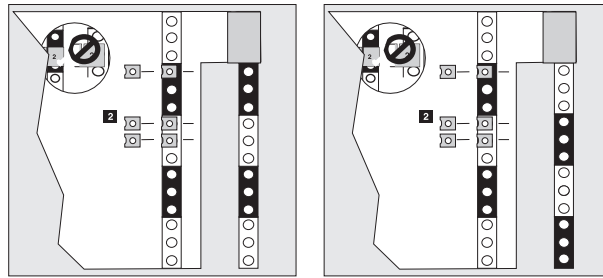

IPHBF817-1

Figure 136. Rack template

Note: The front of the rack-mounting template has printed illustrations designed to help you identify the EIA location holes to be used when you add units to the rack. *Do not* use the rack-mounting template without completing the following steps.

2. Note the following when using the rack-mounting template:
 - Each black or white unit on the template is equal to one EIA unit.
 - Each EIA unit consists of three holes.
 - The EIA units illustrated on the template must be aligned with the EIA units located on the rack.
 - It is not necessary to align like-colored EIA units. For example, a black EIA unit on the rack-mounting template can be aligned with a white EIA unit located on the rack.
 - The template is two-sided. When using the template, ensure that the appropriate side of the template is facing out.

Figure 136 shows one EIA unit and five EIA units. Depending on the rack manufacturer, the EIA units might be separated either by color or by a line. Notice that the holes along the rail are not evenly spaced. If your rack has no color or line separation between EIA units, assume that each EIA unit begins where the hole spacing is closest together as shown, **A** in Figure 137.

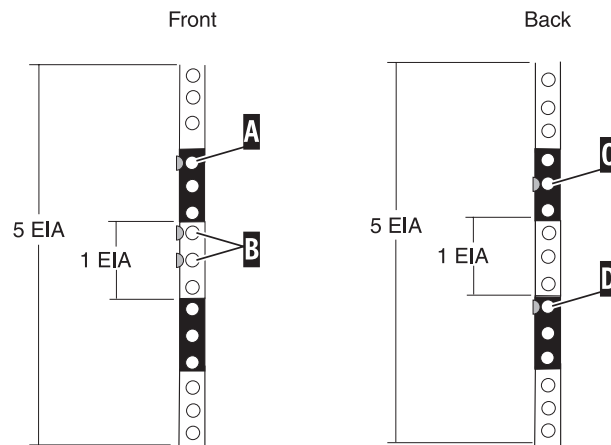

IPHBF812-0

Figure 137. EIA units

To use the rack-mounting template, complete the following steps:

- a. Remove the protective coating from each adhesive strip located on the back of the rack-mounting template. Lightly press the template into position on the rack. Ensure that both the left and right sides are at the corresponding EIA locations.

Note: The tabs on each side of the template show a notch to indicate the correct spacing between the front flanges.

- b. Locate the dots, printed on the left and right side of the template. Place a self-adhesive dot directly across from the template's printed dots on or near the rack's EIA numbering strip. You will be using these dots to aid in correctly positioning the rail-alignment pins located on the front of each rail.
- c. Remove the rack-mounting template from the front of the rack. The front of your rack should now contain dots.
- d. Mount the rack-mounting template to the rack's back EIA frame. Place the rack-mounting template at the same EIA-numbered location that was used on the front of the rack.
- e. Wrap a self-adhesive dot directly across from the template's printed dots. Ensure that a portion of the self-adhesive dot wraps around the rack frame so that it can be seen from the front of the rack.
- f. Remove the rack-mounting template from the back of the rack. The back of your rack should now contain dots that have been partially wrapped around the frame.

Marking the location without a rack-mounting template:

You might need to mark the location without a template. Use the procedure in this section to perform this task.

If you do not have a rack-mounting template, complete the following steps:

1. Determine where in the rack to place the system. Install units in the lower part of the rack first. Place larger and heavier units in the lower part of the rack. Record the EIA location.
 - Each EIA unit consists of three holes.
 - This system is five EIA units high.
2. Facing the front of the rack and working from the right side, place a self-adhesive dot next to the top hole of the third EIA unit (from the bottom) of the five EIA units you will be using for this system unit as shown in **A** in Figure 138.

Note: The self-adhesive dots are used to aid in identifying locations on the rack. If do not have the dots, use some other form of marking tool to aid you in identifying hole locations (for example, tape or a marker).

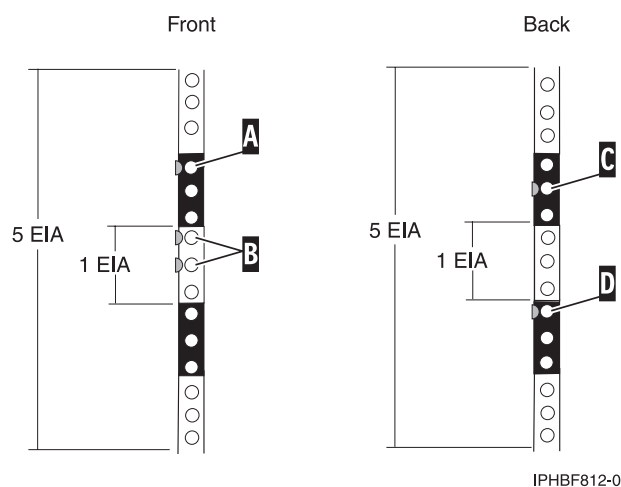

Figure 138. Marking holes on the front and back of the rack frame.

3. Place another self-adhesive dot next to the top hole of the second EIA unit from the bottom as shown in **B** in Figure 138.

4. Place another self-adhesive dot next to the middle hole of the second EIA unit from the bottom as show in **B** in Figure 138 on page 136.
5. Mark the identical locations on the front left-side of the rack.
6. Go to the back of the rack. On the right side, place a self-adhesive dot next to the middle hole of the third EIA unit from the bottom, **C** in Figure 138 on page 136.
7. Place a self-adhesive dot at the top hole of the first EIA unit, **D** in Figure 138 on page 136.
8. Mark the corresponding holes on the left side of the rack.

Attaching the mounting hardware to the rack

You might need to attach the mounting hardware to the rack. Use the procedure in this section to perform this task.

CAUTION:

Installing the rails in the rack is a complex procedure. To install the rails correctly, you must perform each task in the following order. Failure to do so might cause rail failure and potential danger to yourself and the system unit.

To install the rack-mounting hardware into the rack, complete the following steps:

1. Using the cage-nut insertion tool or a flat-blade screwdriver, install cage nuts (for square rack-rail mounts) or clip nuts (for round rack-rail mounts) into the marked locations on the left and right rack rails.

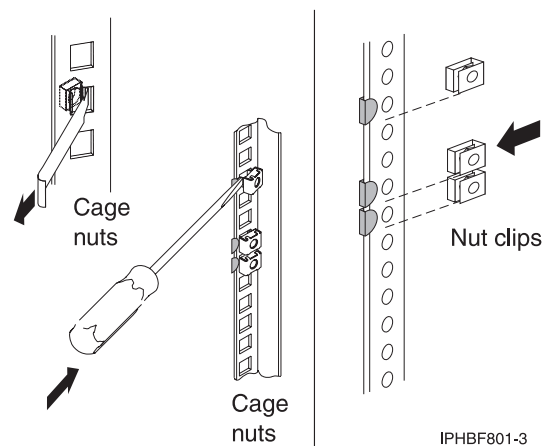

Figure 139. Attaching the cage nuts or nut clips to the rack rails.

2. From the back of the rack, use the tab **A** on the back of the slide rails to align the slide rail to the back of the rack.

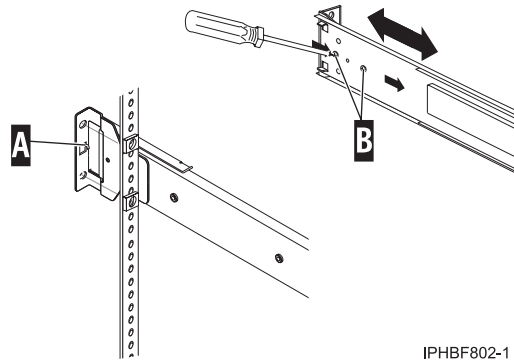

Figure 140. Aligning and adjusting the length of the rails.

3. If necessary, adjust the length of the slide rail by using a flat-blade screwdriver to loosen the two adjustment screws **B** on the back of the rail to expand or contract the rail.

Note: You might need to extend the rail slides to access the adjustment screws **B**.

4. Locate the cable-management arm pivot bracket **C**. Using two M6 screws, secure the cable-management arm pivot bracket to the *left rail* (when you are facing the front of the rack) and into the rack.

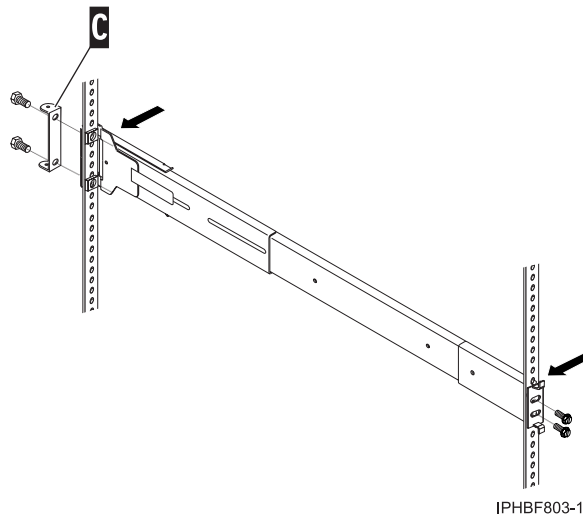

Figure 141. Attaching the rails to the rack (cable-management arm pivot bracket pictured).

5. Using two M6 screws, attach the right rail to the back left of the rack.

Note: There is no bracket for the right rail.

6. Moving to the front of the rack, use two M6 screws to secure the right rail to the front of the rack.
7. Use two M6 screws to secure the left rail to the front of the rack.
8. Tighten the screws that you used to adjust the length of the rail in Figure 140

Installing the cable-management arm

You might need to install the cable-management arm. Use the procedure in this section to perform this task.

To install the cable-management arm, complete the following steps:

Use the hinge pin **A** to attach the cable-management arm **B** to the cable-management hinge bracket.

Note: Ensure that the lever **C** is in the horizontal position inside the rack cabinet to prevent the cables from touching the back door of the rack.

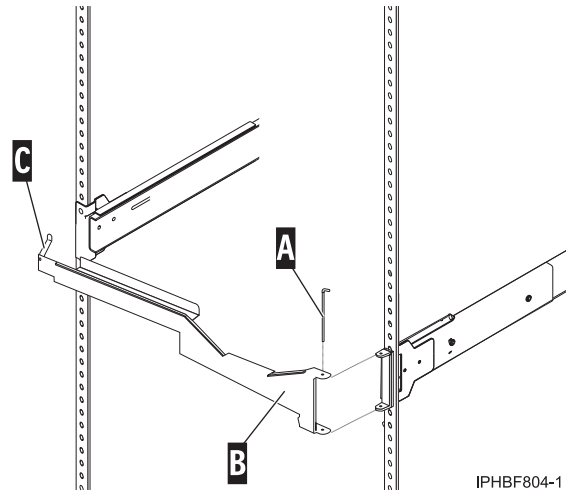

Figure 142. Attaching the cable-management arm bracket.

Installing the system unit on the rail assembly

You might need to install the system on the rail assembly. Use the procedure in this section to perform this task.

Before installing the 7037-A50 system unit on the rail assembly, ensure that the stabilizers are extended and the stabilizer plate is attached to the bottom front of the rack to prevent the rack from falling forward when the rails are pulled out of the rack. Refer to *Install the rack*.

To install the 7037-A50 on the rail assembly, complete the following steps:

1. The optional latch brackets may be preinstalled. If the latch brackets are not preinstalled and you want to install them, see “Installing or removing a rack-mounted system-unit latch bracket” on page 67 and return to this section.
2. Ensure that the four blue rack-support wheels **A** are securely installed on the side of the system.

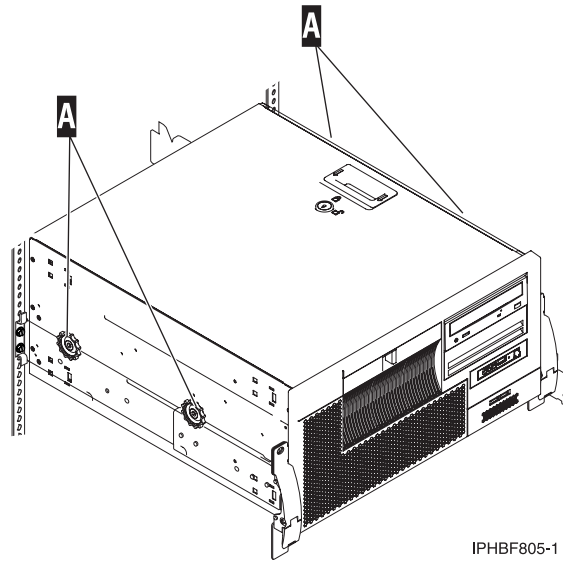
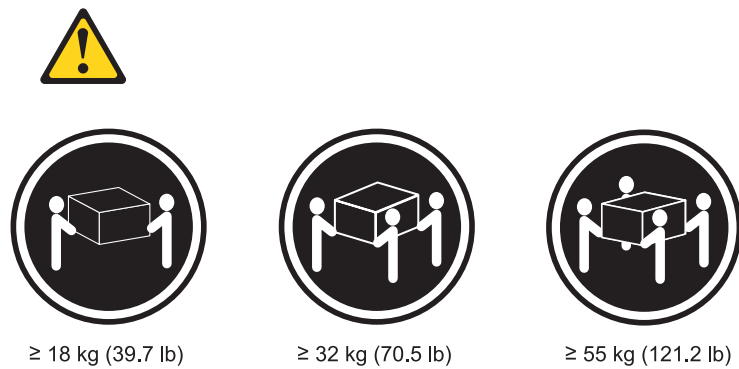

Figure 143. Rack-support wheels.

3. Fully extend the slide rails out of the rack.
4. Using at least two people, lift the system above the rails and rest the system on the rack-support wheels A on the rails.



IPHBF442-0

5. Carefully slide the system to align the screw holes on the slide rails with the system chassis.

Note: The front hole of the rail will align with the first hole in the system chassis.

6. Attach four M4 screws C on each side of the system to secure the system to the rails.

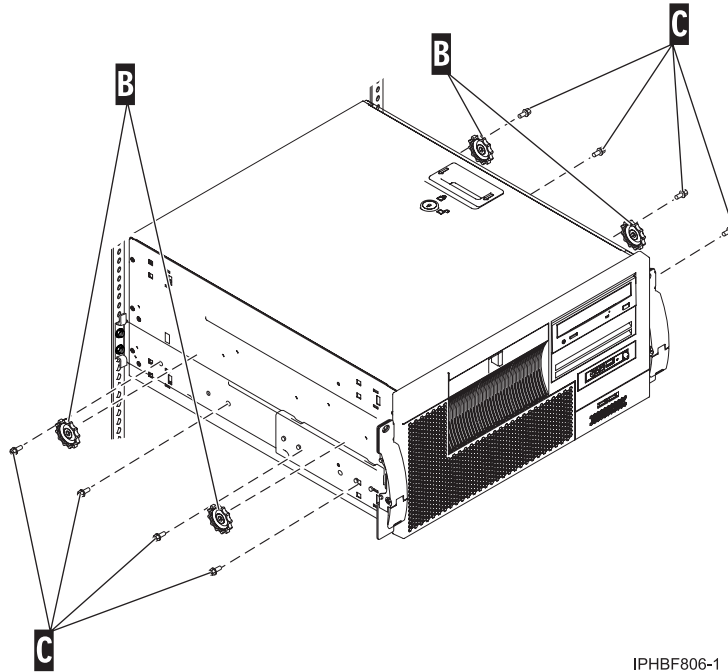

IPHBF806-1

Figure 144. Securing the system to the rails and removing the rack-support wheels.

7. Remove the four blue rack-support wheels **B**.

CAUTION:

Ensure that all eight screws are securely attached through the rail and into the system before removing the rack-support wheels. If the screws have not been inserted, the system may fall when the rack-support wheels are removed.

8. Using two M4 screws, install the cable bracket restraint **D** on the back left-side of the system.

Note: The bracket will face and be bent slightly outward.

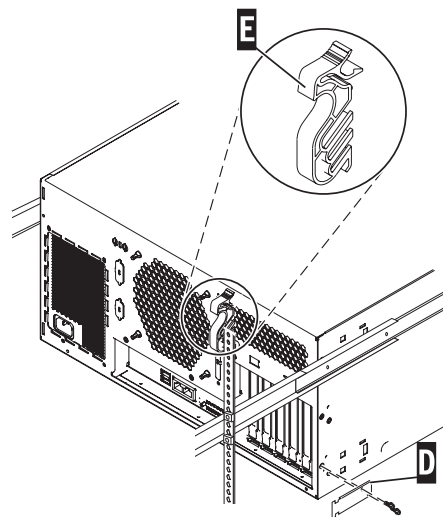

IPHBF807-1

Figure 145. Securing the system to the rails and removing the rack-support wheels.

9. Install the cable clamp **E** on the back of the system.
10. Attach and route the cables.

11. Simultaneously depress the safety latches, located on both sides of the rails **F** in Figure 146 and push the system unit into the rack.

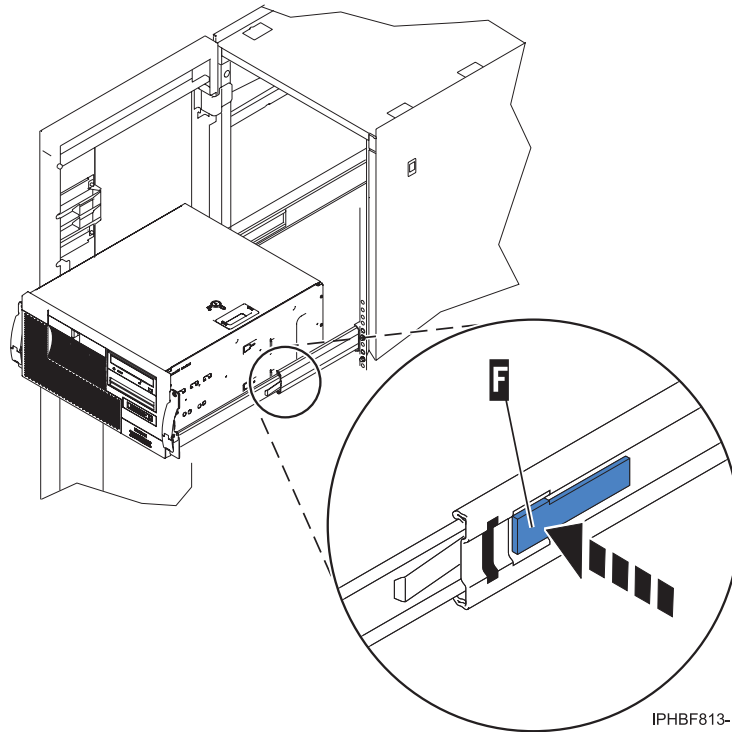

Figure 146. Press the safety latches and push the system unit into the rack.

12. Slide the system drawer in and out of the rack two or three times. This action aligns the system drawer with the rails.
13. Push the system drawer back into the rack. Using a screwdriver, tighten the rail-retaining screws that secure the slide rails to the rack's rear flange on each side of the rack.
14. Slide the system drawer about halfway out of the rack.
15. Using a screwdriver or similar tool, tighten the front rail-retaining screws that secure the slide rails to the rack's front flange on each side of the rack.

Note: After the system rails are installed, do not extend them past their safety latches. The safety release latches stop the rails from overextending and separating. This action prevents the system drawer from being accidentally pulled out too far and dropped.

Attention: If any binding is detected, loosen the rail-retaining screws (front and back), and repeat steps 11 through 15.

16. When transporting the rack, fasten the system drawer to the rack enclosure by inserting the transport retaining screw **I** through the bezel and latch bracket **H**, and screwing it to the rack and second optional screw **G** that prevents the rail from sliding as shown in Figure 147 on page 143.

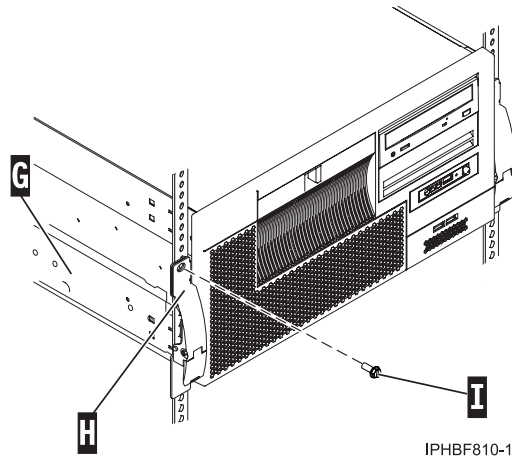

Figure 147. Transport retaining screws.

Installing the model 7031-D24 into a rack

You might need to install the system into a rack. This section includes procedures so that you can perform these tasks.

This procedure assumes that you are installing the system into an existing rack. If the rack is not installed, go to the instructions for installing the rack and then return to this procedure for instructions on installing the system unit into the rack.

When you have installed the system into the rack, you will need the instructions in Disk drive to connect and configure the 7031-D24.

Note: This procedure applies only to the models that are designed to be mounted into a rack.

To install the system into a rack, perform the following tasks:

Attention: Installing the rails in the rack is a complex procedure. To install the rails correctly, you must perform each task in order. Failure to do so might cause rail failure and potential danger to yourself and the system unit.

1. Read the "Rack Safety Notices" on page 1. Failure to read these notices could cause damage to the equipment or injury to the installer.
2. Complete a parts inventory (See "Completing a parts inventory" on page 3).
3. Locate the rack-mounting template **A**, the rack-mounting hardware kit **B**, and the system rail assemblies **C** that were included with your system unit. The system rails are identical.

Note: An 8-mm nut driver and a flat-blade screwdriver, represented in the following diagram, are not listed in the inventory or included in the parts shipped, but these tools will assist you in completing the installation.

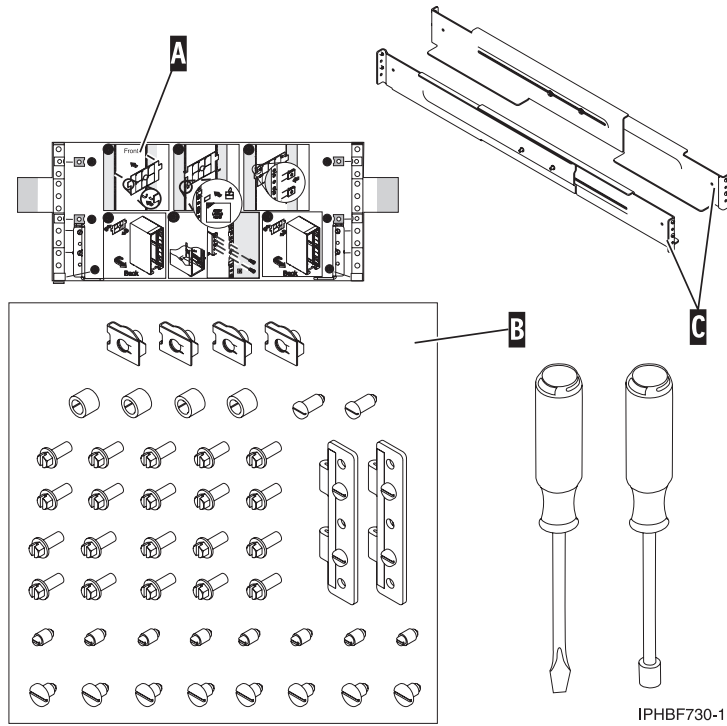

Figure 148. Parts inventory

4. Determine where you will locate the expansion unit in the rack. See “Determining the location.” This system unit is 4 EIA units high.
5. Mark the location. See “Marking the location using rack-mounting template” on page 145. If you do not have the rack-mounting template, see “Marking the location without a rack-mounting template” on page 147.

Determining the location

You might need to determine where to install an expansion unit in the rack. This section includes procedures so that you can perform these tasks.

Before installing the expansion unit into a rack, complete the following steps:

1. Read the “Rack Safety Notices” on page 1.
2. Plan where you will place the units. Place the larger and heavier units in the lower part of the rack. These expansion units are four EIA units high.
3. Remove the filler panels to allow access to the inside of the rack enclosure where you plan to place the unit.

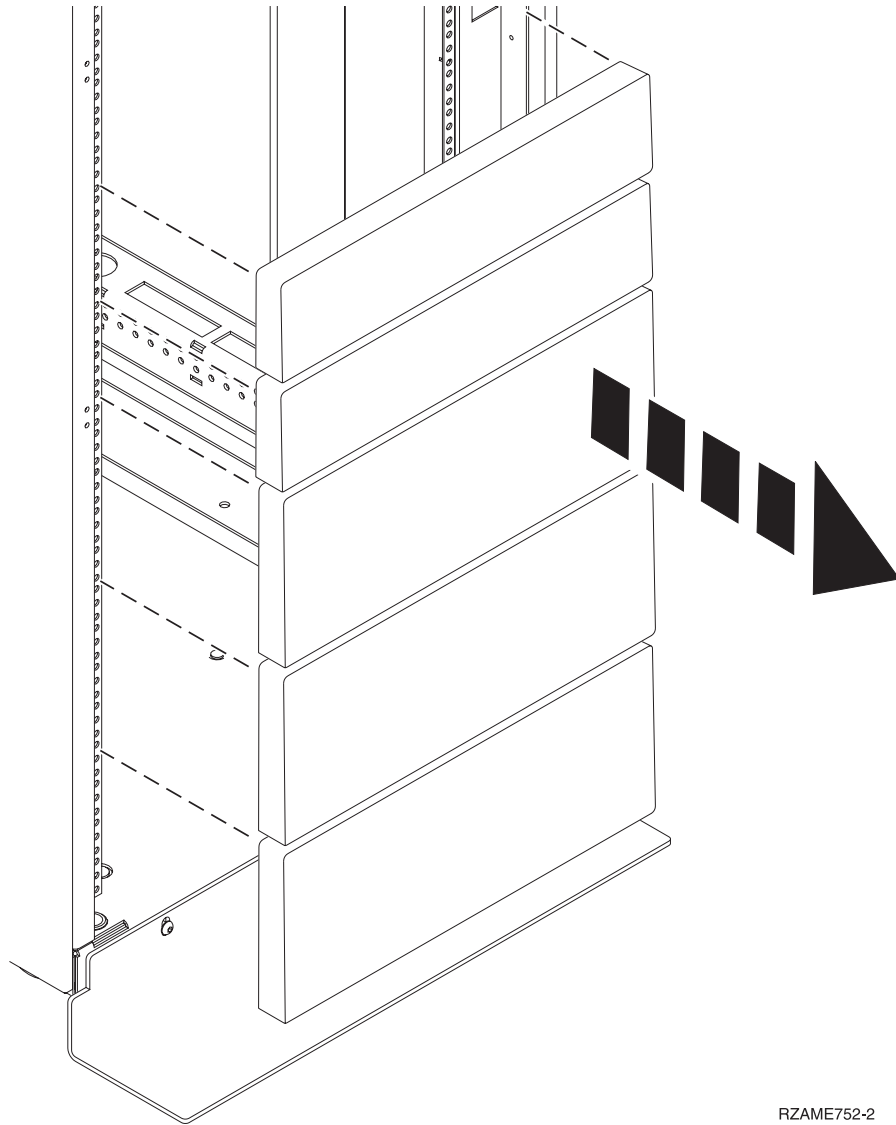

RZAME752-2

Figure 149. Removing the filler panels.

4. Remove the front and back rack doors if necessary.
5. Use the rack-mounting template to mark the location (see Mark location using rack-mounting template). If you do not have a rack-mounting template, follow the instructions for marking the location without a template (see Mark location without rack-mounting template).

Marking the location using rack-mounting template:

You might need to mark the installation location using a rack-mounting template. Use the procedure in this section to perform this task.

1. Using the rack-mounting template, determine where in the rack to place the system unit. Install units in the lower part of the rack first. Place larger and heavier units in the lower part of the rack.

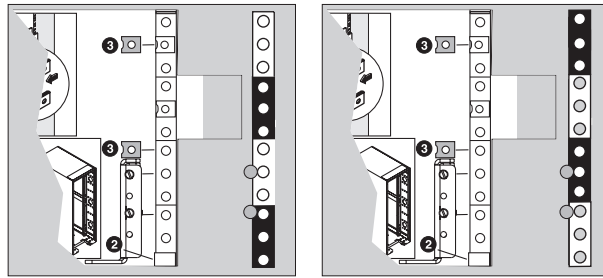

IPHBF734-1

Figure 150. Example of a rack-mounting template.

Note: The front of the rack-mounting template has printed illustrations designed to help you identify the EIA location holes to be used when you add units to the rack. *Do not* use the rack-mounting template without completing the following steps.

2. Note the following when using the rack-mounting template:
 - Each black or white unit on the template is equal to one EIA unit.
 - Each EIA unit consists of three holes.
 - The EIA units illustrated on the template must be aligned with the EIA units located on the rack.
 - It is not necessary to align like-colored EIA units. For example, a black EIA unit on the rack-mounting template can be aligned with a white EIA unit located on the rack.
 - The template is two-sided. When using the template, ensure that the appropriate side of the template is facing out.

Figure 151 shows one EIA unit and four EIA units. Depending on the rack manufacturer, the EIA units might be separated either by color or by a line. Notice that the holes along the rail are not evenly spaced. If your rack has no color or line separation between EIA units, assume that each EIA unit begins where the hole spacing **A** is closest together.

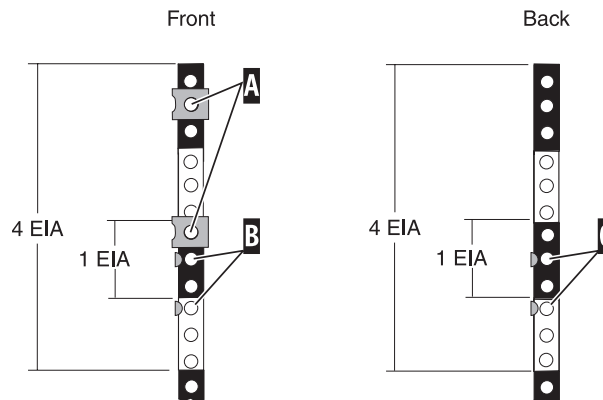

IPHBF733-2

Figure 151. EIA units example.

To use the rack-mounting template, follow these steps:

- a. Remove the protective coating from each adhesive strip located on the back of the rack-mounting template. Lightly press the template into position on the rack. Ensure that both the left and right sides are at the corresponding EIA locations.

Note: The tabs on each side of the template show a notch to indicate the proper spacing between the front flanges.

- b. Locate the dots, printed on the left and right side of the template. Place a self-adhesive dot directly across from the template's printed dots on or near the rack's EIA numbering strip. You will be using these dots to aid in correctly positioning the rail-alignment pins located on the front of each rail.
- c. Remove the rack-mounting template from the front of the rack. The front of your rack should now contain dots.
- d. Mount the rack-mounting template to the rack's back EIA frame. Place the rack-mounting template at the same EIA-numbered location that was used on the front of the rack.
- e. Wrap a self-adhesive dot directly across from the template's printed dots. Ensure that a portion of the self-adhesive dot wraps around the rack frame so that it can be seen from the front of the rack.
- f. Remove the rack-mounting template from the back of the rack. The back of your rack should now contain dots that have been partially wrapped around the frame.

Marking the location without a rack-mounting template:

You might need to mark the location without a template. Use the procedure in this section to perform this task.

If you do not have a rack-mounting template, complete the following steps:

1. Determine where in the rack to place the system. Record the EIA location.
2. Note the following:
 - Each EIA unit consists of three holes.
 - The expansion unit is 4 EIA units high.
3. Facing the front of the rack and working from the left side, place a supplied self-adhesive dot next to the top hole **B** of the first EIA unit that you selected.

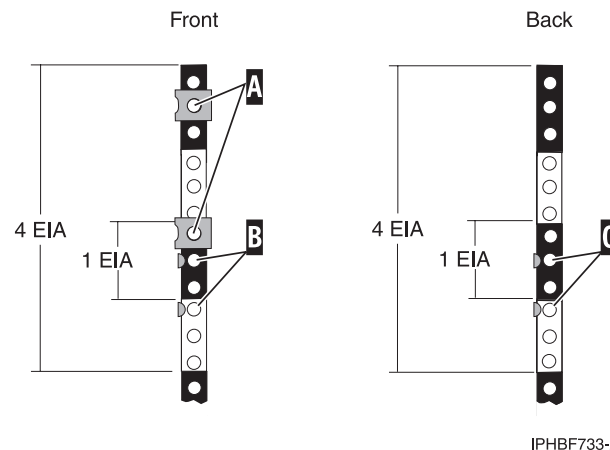

Figure 152. Marking the installation locations.

Note: The self-adhesive dots are used to aid in identifying locations on the rack. If do not have any of the dots, use some other form of marking tool to aid you in identifying hole locations (for example, tape, a marker, or pencil).

4. On the left rail, place another self-adhesive dot next to the middle hole **B** of the second (EIA unit above) EIA unit. There will be one hole between the dots.
5. Repeat these steps to place the two adhesive dots on the front-right rail.
6. Go to the back of the rack. On the left side, find the EIA unit that corresponds to the bottom EIA unit marked on the front of the rack.
7. Place a self-adhesive dot at the top hole **C** of the bottom EIA unit.

8. Place a self-adhesive dot at the middle hole **C** of the second (above) EIA unit.
9. Mark the corresponding holes on the right side of the rack.

Attaching the mounting hardware to the rack

You might need to attach mounting hardware to the rack. Use the procedure in this section to perform this task.

CAUTION:

Installing the rails in the rack is a complex procedure. To install the rails correctly, you must perform each task in the following order. Failure to do so might cause rail failure and potential danger to yourself and the system unit.

To install the mounting hardware into the rack, follow these steps:

1. Loosen the two screws **B** in the middle of both rails **A** to allow each rail to extend.

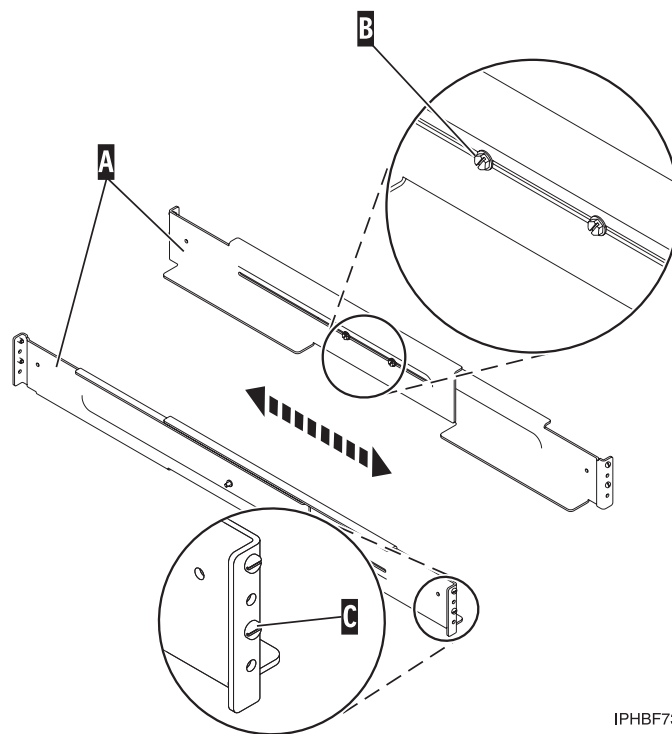

IPHBF731-0

Figure 153. Extending the system rails.

2. Starting at the back of the rack, extend the left rail and insert the rail pins **C** into the marked locations the rack so that the rail is facing upward.

Note: Although the rail installation can be completed by one person, the installation will be easier if one person is positioned at the front of the rack and one person is positioned at the back of the rack.

3. From the back of the rack, extend the right rail and insert the rail pins **C** into the marked locations.
4. Moving to the front of the rack, extend the left rail and insert the rail pins **C** into the marked locations.
5. Extend the right rail and insert the rail pins **C** into the marked locations.
6. Using two M5 screws **D**, secure the left rail to the front of rack below each rail pin **C**.

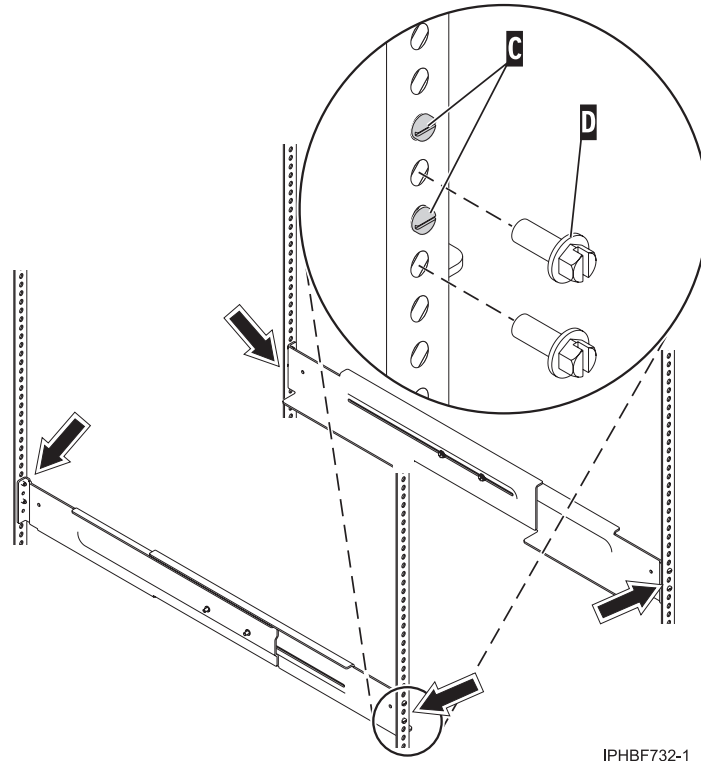

IPHBF732-1

Figure 154. Attaching the system rails.

7. Using two M5 screws **D**, secure the right rail to the front of the rack.
8. Moving to the back of the rack and using two M5 screws **D**, secure the left rail to the back of the rack.
9. Using two M5 screws **D**, secure the right rail to the back of the rack.
10. Tighten the two screws in the middle of the left rail and the two screws in the middle of the right rail. Refer to Figure 154.
11. Insert two nut clips at the marked location on the front-left rail.
12. Insert two nut clips at the marked locations on the front-right rail.

Installing the 7031-D24 on the rail assembly

You might need to install the system on the rail assembly. Use the procedure in this section to perform this task.

Before installing the system on the rail assembly, ensure that the stabilizers are extended and the tip plate is attached to the bottom front of the rack to prevent the rack from falling forward when the rails are pulled out of the rack. Refer to “Rack Safety Notices” on page 1.

To install the system unit on the rail assembly, follow these steps:

1. If the bezel is installed on the front of the system, remove it by pressing in on the two release buttons.

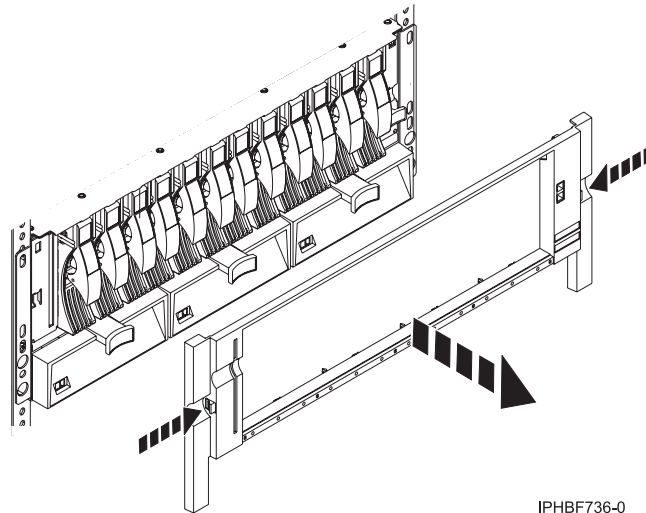

IPHBF736-0

Figure 155. Removing the bezel.

2. Using three people, lift the system unit and position it over front of the rails.

Attention: Three people are required to safely lift the system. Using fewer than three people to lift the system can result in injury.
3. Push the system into the rack until it is completely installed into the rack.
4. If the securing plates are not preinstalled on the back of the system, attach the plates to the back left and back right of the system. The securing plates are illustrated in Figure 157 on page 151.
5. Install the two M5 securing screws **A** through the chassis and into the nut clips **B** on the left and right rail.

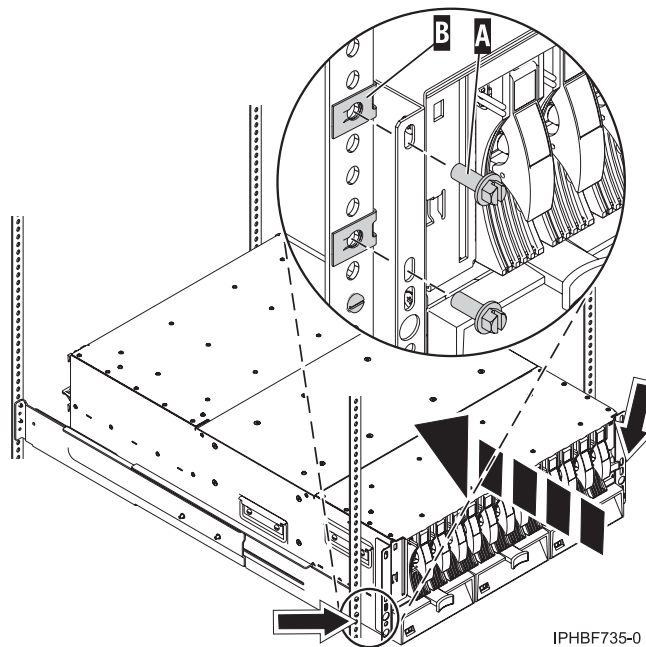

IPHBF735-0

Figure 156. Installing the securing screws.

6. At the back of the rack, install two M5 securing screws **C** through the back of both the left and right securing plates and into the rack rail.

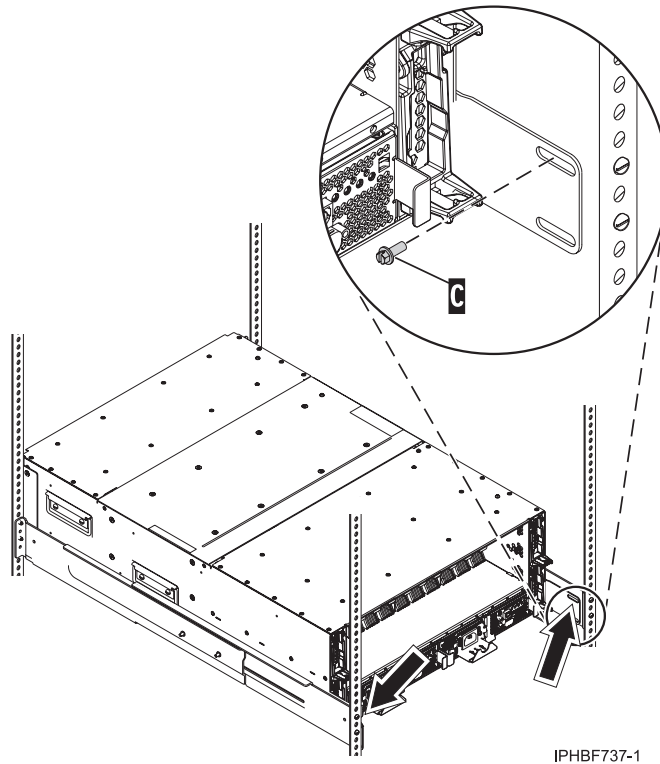

IPHBF737-1

Figure 157. Securing the system to the back of the rack.

7. Install the bezel onto the system.

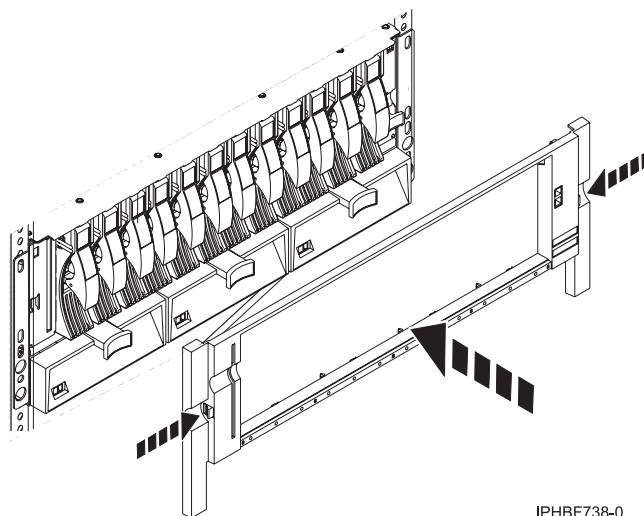

IPHBF738-0

Figure 158. Installing the bezel.

For instructions on how to connect and configure the system when you have completed installing the 7031-D24 into the rack, see *Connecting the 7031-D24 or 7031-T24 SCSI disk drive enclosure*.

Installing the 5088 or 0588 expansion unit into a rack

You might need to install an expansion unit into the rack. Use the procedure in this section to perform this task.

This procedure assumes that you are installing the model 5088 or the 0588 expansion unit into an existing rack. If the rack is not installed, go to the instructions for Install the rack. and then return to this procedure for instructions on installing the expansion unit into the rack.

Note: This procedure applies only to the models that are designed to be mounted in a rack. Do not attempt to install a stand-alone model in a rack.

To install the 5088 or the 0588 expansion unit into a rack, complete the following steps:

CAUTION:

Installing the rails in the rack is a complex procedure. To install the rails correctly, you must perform each task in the following order. Failure to do so might cause rail failure and potential danger to yourself and the system unit.

1. Read the "Rack Safety Notices" on page 1.
2. Complete a parts inventory.
 - Locate the kitting report in an accessory box.
 - Ensure that you received all the parts that you ordered.If there are incorrect, missing or damaged parts contact:
 - Your IBM reseller
 - IBM Rochester Manufacturing Automated Information Line at 1-800-300-8751 (United States only)
 - <http://www.ibm.com/planetwide>: Locate your service and support telephone numbers
3. If necessary, remove the front and the back doors of the rack to gain adequate access to EIA rails.
4. Install the right rail.
 - a. Starting with the lowest EIA unit available, or EIA unit one in an empty rack, insert the rail with pins toward the front of the rack.
 - b. Install four nut clips in the EIA rail in the back of the rack.
 - c. Secure the drawer rail to the back EIA rail using four screws.
5. Attach the cable bracket to the right drawer rail.
 - a. Insert the flange of the cable bracket into the hole of drawer rail with the cable bracket facing up.
 - b. Rotate the cable bracket down until the screw can be installed through the drawer rail and into the cable bracket.
 - c. Install the back rack bracket.

Note: The 5088 or the 0588 expansion units are eight EIA units high.

 - Install two nut clips on the back of the EIA rail.
 - Secure the back rack bracket to back EIA rail with two screws. *Do not* fully tighten the bracket at this time to allow space for sliding in the expansion unit later.
6. Repeat the rail mounting procedure for left rail, cable bracket, and the back rack bracket.
7. Remove the black outer cover from the front of the expansion unit.
8. Remove the perforated ESD cover from the front of the expansion unit.
9. Remove the plenum assembly from the back of the expansion unit.
10. Remove the power supplies.
 - a. Unplug the power cord from power supply.
 - b. Pull out the blue knob and pull handle down.
 - c. Slide the power supply out of the chassis.
 - d. Repeat the above substeps for the second supply (if applicable).
11. Using two people, place expansion unit into the rack. Position the expansion unit with the power supplies facing toward the front of the rack.

12. Attach the expansion unit to the rack.
 - a. Install two nut clips on each EIA rail on the front of rack and secure them with four screws.
 - b. With 5088 or the 0588 expansion unit secured to front of rack, position and secure the back rack brackets.
13. Reinstall the power supplies in the expansion unit. Ensure that the power supplies are fully seated in the chassis.
14. Install the front perforated ESD cover on the expansion unit.
15. Install the plenum assembly on back of expansion unit. The plenum assembly slides on top of the L-shaped brackets on the inner sides of the expansion unit.
16. Connect the ac power cords from the expansion unit to power distribution unit (PDU) power outlets. If the dual line cord feature is present on system, ensure that the ac power line cords are connected to separate PDU power outlets.
17. Install the black outer cover to front of expansion unit.
18. Install the front or the back door to the rack if they were previously removed from the rack.

Installing the 5095, 0595, or 7311-D20 expansion unit into a rack

You might need to install an expansion unit into the rack. Use the procedure in this section to perform this task.

This procedure assumes that you are installing the model 5095, 0595, or 7311-D20 expansion unit into an existing rack. If the rack is not installed, go to the instructions for Install the rack. and then return to this procedure for instructions on installing the system unit into the rack.

Note: This procedure applies only to the models that are designed to be mounted in a rack. Do not attempt to install a stand-alone model in a rack.

To install the 5095, 0595, or 7311-D20 into a rack, complete the following steps:

1. Read the “Rack Safety Notices” on page 1.
2. Unpack the template and rack hardware.

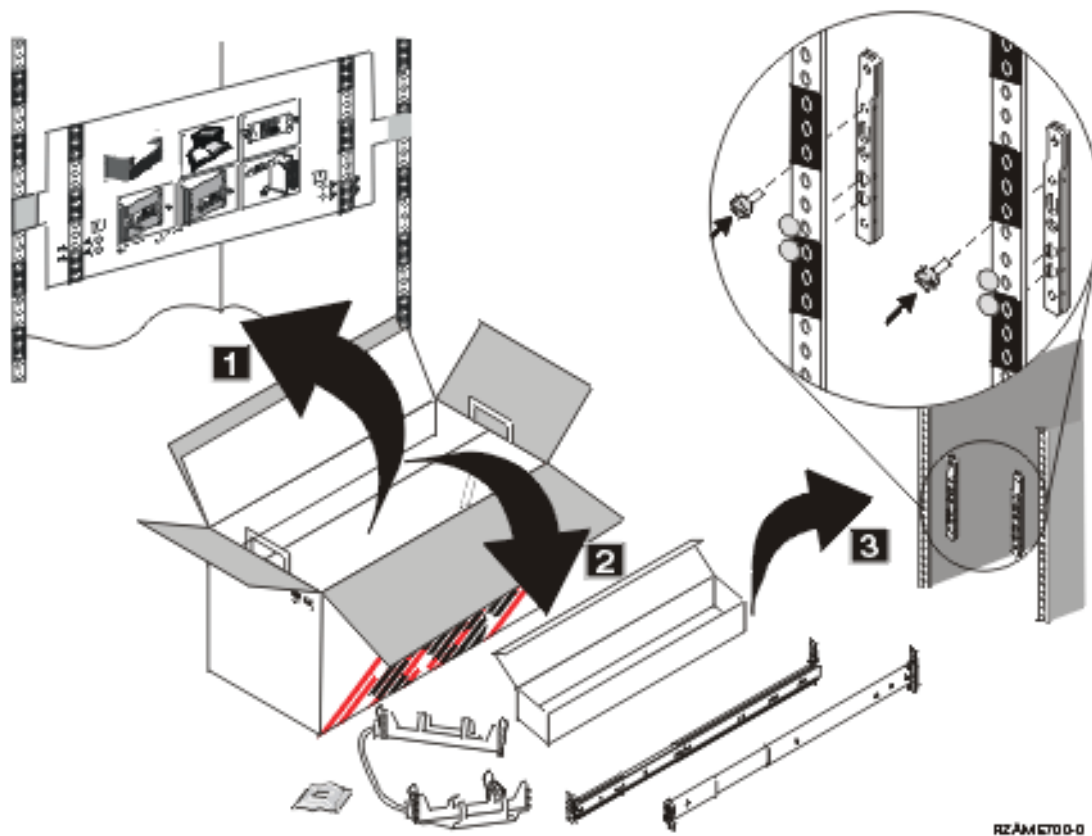

Figure 159. Unpacking the rack template and hardware.

3. Complete a parts inventory (See “Completing a parts inventory” on page 3).
4. Determine where you will locate the expansion unit in the rack. See Locate in rack.
5. Mark the location. See “Marking the location using a rack-mounting template” on page 156. If you do not have the rack-mounting template, see “Marking the location without a rack-mounting template” on page 158.

Attaching the cable-management arm to the standard rails

You might need to attach the cable-management arm. Use the procedure in this section to perform this task.

If standard (fixed length) rails were included with the system, and the cable-management arm is not attached to the rails, complete the following steps. Otherwise, go to “Determining the location” on page 155.

1. Insert the cable-management arm rail tab **B** into the rail.
2. Rotate the cable-management arm **A** as shown in the following illustration.

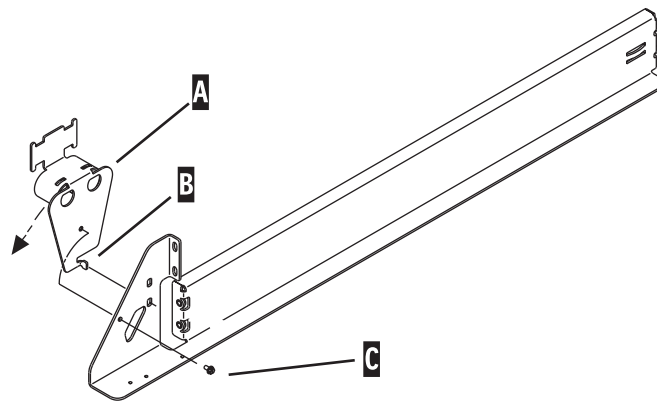

Figure 160. Rotating the cable-management arm.

3. Secure the cable-management arm **A** with the retaining screw **C**.
4. Repeat steps 1 through 3 for the other rail.

Determining the location

You might need to determine where to install the expansion unit in the rack. This section includes procedures so that you can perform these tasks.

Before installing the system unit or expansion unit into a rack, complete the following steps:

1. Plan where you will place the units. Place the larger and heavier units in the lower part of the rack.
2. If necessary, remove the filler panels to allow access to the inside of the rack enclosure where you plan to place the unit.

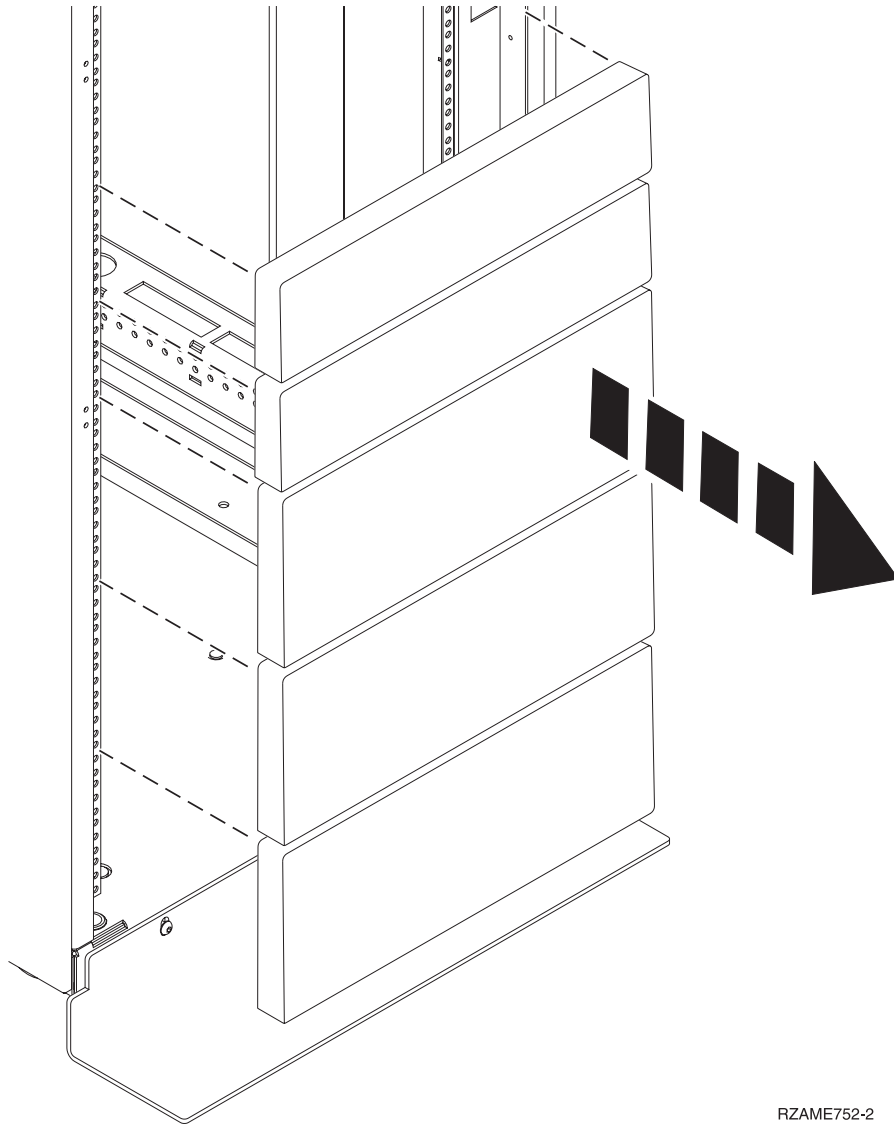

RZAME752-2

3. If necessary, remove the front and back rack doors.
4. Use the rack-mounting template to mark the location. See “Marking the location using a rack-mounting template.” If you do not have a rack-mounting template, follow the instructions for marking the location without a template, see “Marking the location without a rack-mounting template” on page 158.

Marking the location using a rack-mounting template:

You might need to mark the installation location using a rack-mounting template. Use the procedure in this section to perform this task.

1. Using the rack-mounting template, determine where in the rack to place the system unit. Install units in the lower part of the rack first. Place larger and heavier units in the lower part of the rack.

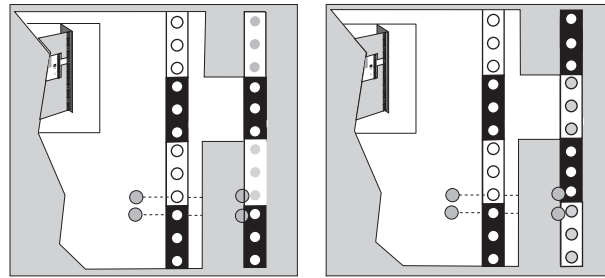

IPHBF502-0

Figure 161. Rack-mounting template

Note: The front of the rack-mounting template has printed illustrations designed to help you identify the EIA location holes to be used when you add units to the rack. *Do not* use the rack-mounting template without completing the following steps.

2. Note the following when using the rack-mounting template:
 - Each black or white unit on the template is equal to one EIA unit.
 - Each EIA unit consists of three holes.
 - The EIA units illustrated on the template must be aligned with the EIA units located on the rack.
 - It is not necessary to align like-colored EIA units. For example, a black EIA unit on the rack-mounting template can be aligned with a white EIA unit located on the rack.
 - The template is two-sided. When using the template, ensure that the appropriate side of the template is facing out.

Figure 162 shows one EIA unit and four EIA units. Depending on the rack manufacturer, the EIA units might be separated either by color or by a line. Notice that the holes along the rail are not evenly spaced. If your rack has no color or line separation between EIA units, assume that each EIA unit begins where the hole spacing **A** is closest together.

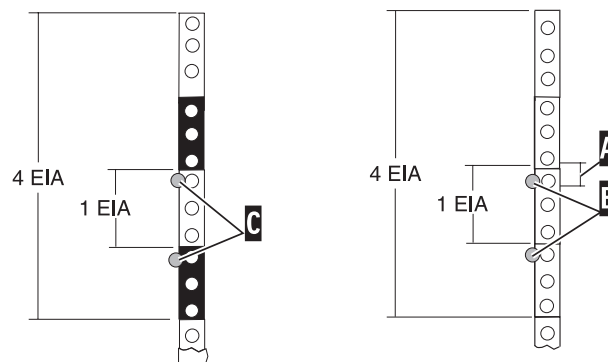

IPHBF503-0

Figure 162. EIA units

To use the rack-mounting template, complete the following steps:

- a. Remove the protective coating from each adhesive strip located on the back of the rack-mounting template. Lightly press the template into position on the rack. Ensure that both the left and right sides are at the corresponding EIA locations.

Note: The tabs on each side of the template show a notch to indicate the proper spacing between the front flanges.

- b. Locate the dots, printed on the left and right side of the template. Place a self-adhesive dot directly across from the template's printed dots on or near the rack's EIA numbering strip. You will be using these dots to aid in correctly positioning the rail-alignment pins located on the front of each rail.
 - c. Remove the rack-mounting template from the front of the rack. The front of your rack should now contain dots.
 - d. Mount the rack-mounting template to the rack's back EIA frame. Place the rack-mounting template at the same EIA-numbered location that was used on the front of the rack.
 - e. Wrap a self-adhesive dot directly across from the template's printed dots. Ensure that a portion of the self-adhesive dot wraps around the rack frame so that it can be seen from the front of the rack.
 - f. Remove the rack-mounting template from the back of the rack. The back of your rack should now contain dots that have been partially wrapped around the frame.
3. Attach the rail assembly to the rack. See "Installing the 5095, 0595, or 7311-D20 rails into the rack."

Marking the location without a rack-mounting template:

You might need to mark the location without a template. Use the procedure in this section to perform this task.

If you do not have a rack-mounting template, do the following:

1. Determine where in the rack to place the system. Record the EIA location.
2. Note the following:
 - Each black or white unit is equal to 1 EIA unit.
 - Each EIA unit consists of three holes.
 - These systems are five EIA units high.
3. Facing the front of the rack and working from the right side, place a supplied self-adhesive dot next to the top hole of the bottom EIA unit.

Note: The self-adhesive dots are used to aid in identifying locations on the rack. If you no longer have any of the dots, use some other form of marking tool to aid you in identifying hole locations (for example, tape, a marker, or pencil).
4. Place another self-adhesive dot next to the bottom hole of the next (above) EIA unit.
5. Repeat steps 3 through 4 for the corresponding holes located on the left side of the rack.
6. Go to the back of the rack. On the right side, find the EIA unit that corresponds to the bottom EIA unit marked on the front of the rack.
7. Place a self-adhesive dot at the middle hole of the bottom EIA unit.
8. Place a self-adhesive dot at the middle hole of the next (above) EIA unit. There will be two holes between the two dots.
9. Mark the corresponding holes on the left side of the rack.
10. Attach two nut clips to the left side of the rack.
 - a. Put the first nut clip in the top hole of the third EIA unit. There will be three holes between this nut clip and the highest dot on the left side.
 - b. Put the second nut clip in the middle hole of the fourth nut clip. There will be one hole between the two nut clips.

Installing the 5095, 0595, or 7311-D20 rails into the rack

You might need to install rails into the rack. Use the procedure in this section to perform this task.

To install the rails into the rack, complete the following steps:

1. Using two screws **A**, attach the left rail assembly to the front of the rack.

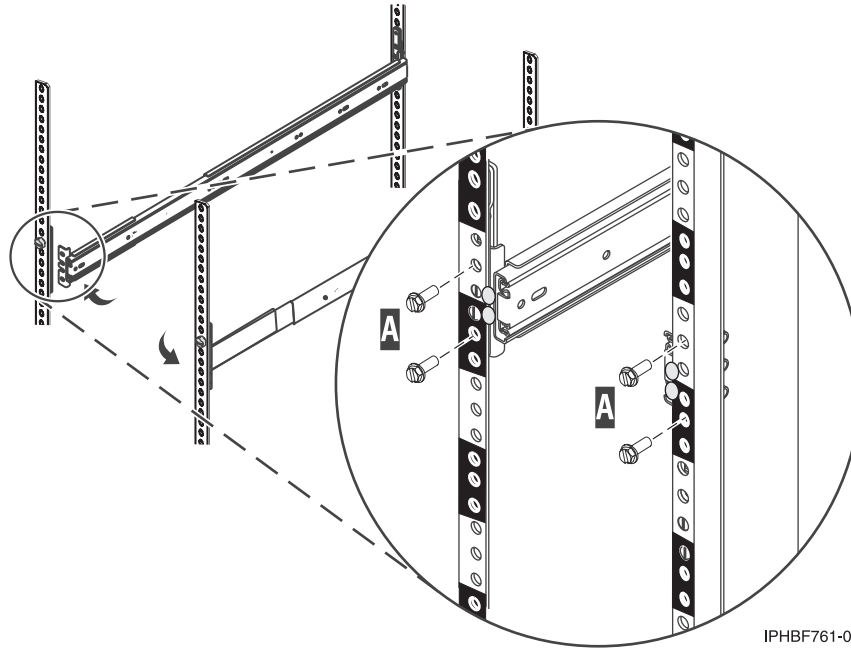

IPHBF761-0

Figure 163. Attaching the rails to the front of the rack.

2. Using two screws **A**, attach the right rail assembly to the front of the rack.
3. Move to the back of the rack.
4. Extend the left and right rails.
5. Using two screws **B**, attach the left rail assembly to the back of the rack.

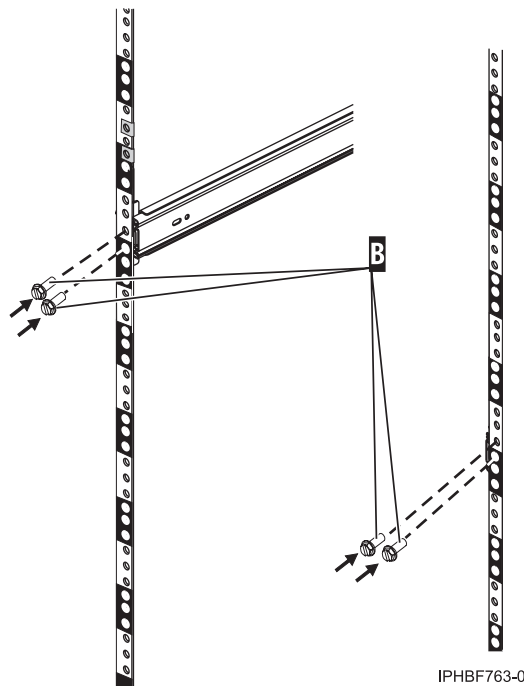

IPHBF763-0

Figure 164. Attaching the rails to the back of the rack.

- Using two screws **B**, attach the right rail assembly to the back of the rack.

Installing the 5095, 0595, or 7311-D20 expansion unit into a rack

You might need to install an expansion unit into a rack. Use the procedure in this section to perform this task.

To install the expansion unit into a rack, complete the following steps:

Attention: This expansion unit weighs in excess of 100 pounds (45 kg). A minimum of three people are required to lift the unit and install it on the rails.

- Using four screws **A**, install the rail-mounting guides **B** to the left and right side of the expansion unit chassis.

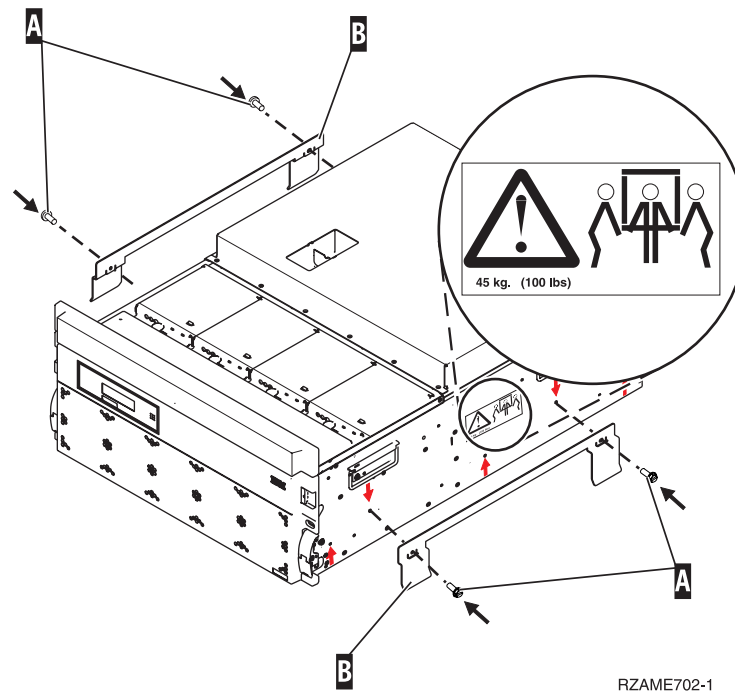

Figure 165. Attaching the rail-mounting guides.

- Extend the rails from the rack until they lock into place.
- Using at least three people, lift the expansion unit onto the rails. The rail guides **B** go over the rails.
- Align the mounting holes on the chassis with their corresponding holes on the rail.
- Install the six screws **C** through the rails and secure the screws to the expansion unit chassis.

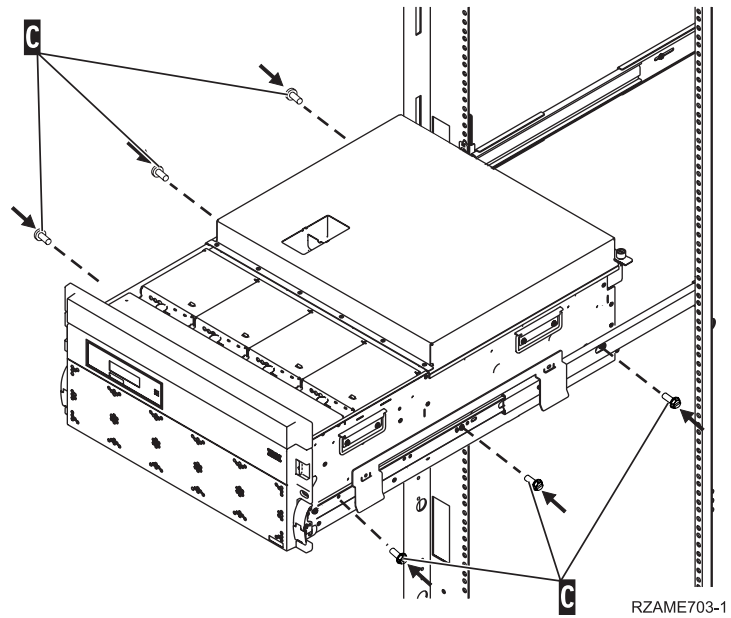

Figure 166. Installing the expansion unit onto the rails.

6. Remove the four screws **A** securing the rail-mounting guides **B** to the expansion unit and remove the rail mounting guides.

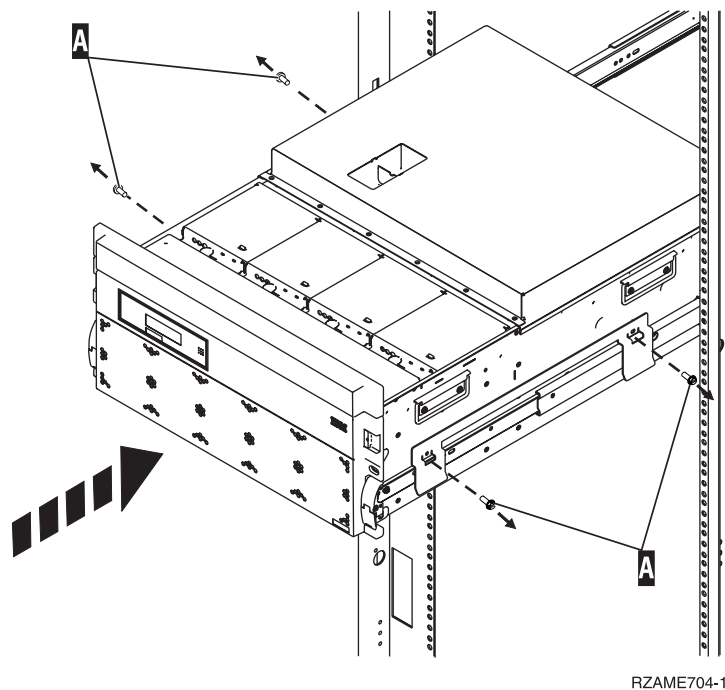

Figure 167. Removing the rail-mounting guides.

7. Slide the system approximately three-quarters of the way into the rack.
8. Move to the back of the rack.
9. Attach one end of the cable-management arm to the back of the rack with two screws **D**. Attach the other end of the arm to the back of the expansion unit with two screws **E**.

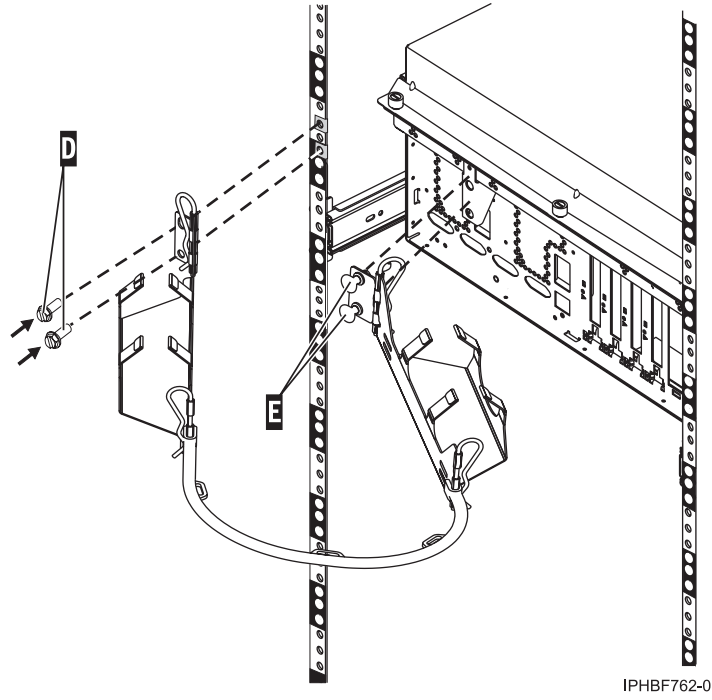

Figure 168. Attaching the cable-management arm.

10. Attach the securing screw mounts **G** with two screws **F** to the left and right rack rails.

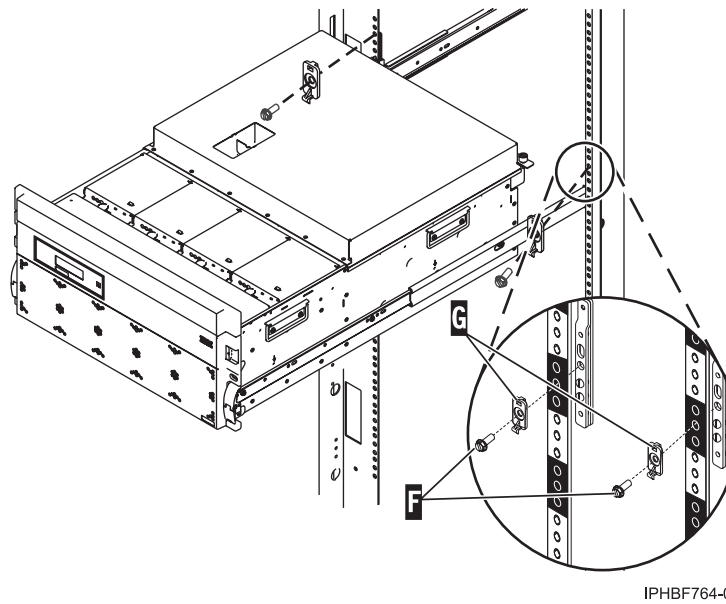

Figure 169. Attaching the securing screw mounts.

11. Slide the expansion unit into the rack.

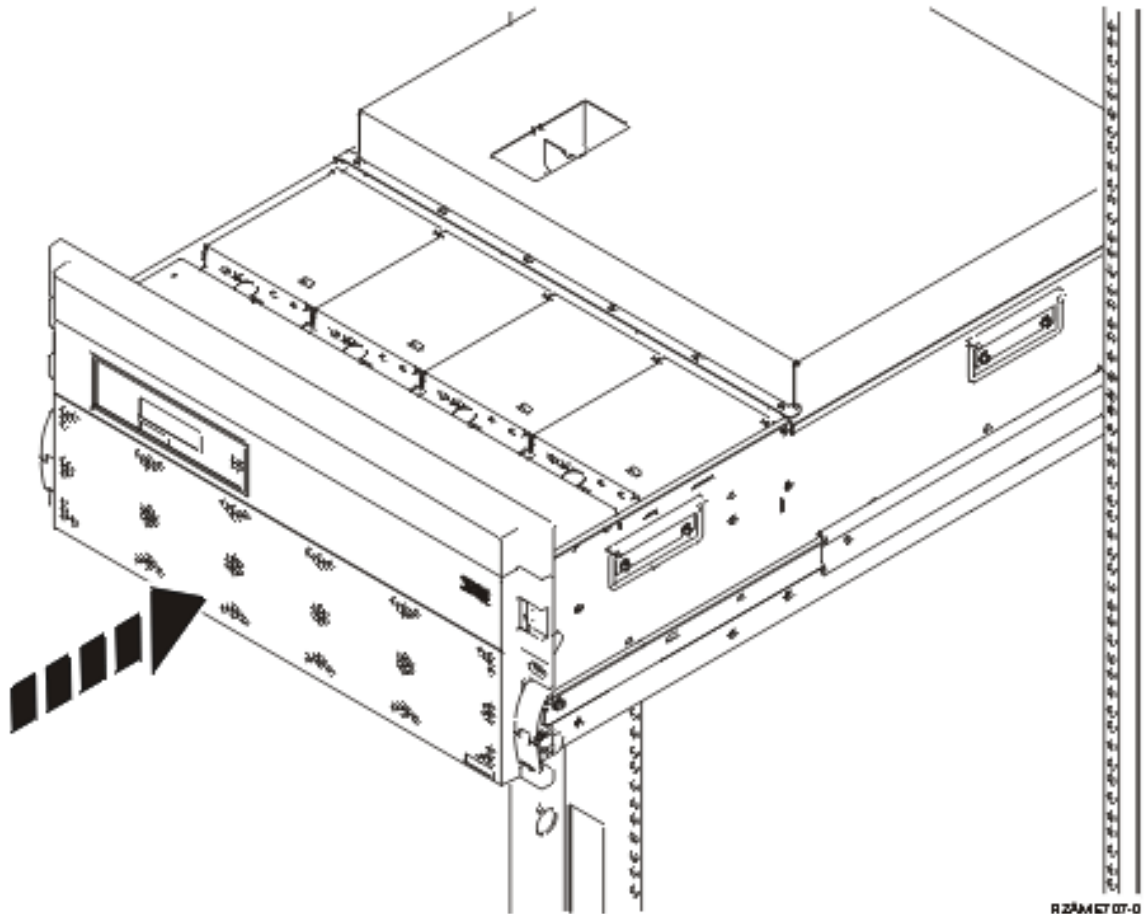

Figure 170. Sliding the expansion unit into the rack.

12. If the system will be transported, install the two securing screws through the front of the expansion unit and into the securing screw mounts.

Installing the 5790 or 7311-D11 expansion unit in a rack

You might need to install an expansion unit into the rack. Use the procedure in this section to perform this task.

This procedure provides instructions for installing the model 5790 or 7311-D11 expansion unit into an existing rack. If the rack is not installed, go to the instructions for Installing the rack, and then return to this procedure for instructions on installing the system unit into the rack.

Restriction: This procedure applies only to the models that are designed to be mounted in a rack. Do not attempt to install a stand-alone model in a rack.

If you are installing a drawer into an existing shell, skip to “Powering off the system and removing power” on page 165. To install the drawer in a new shell, complete the following steps:

Attention: Installing the rails in the rack is a complex procedure. To install the rails correctly, you must perform each task in the following order. Failure to do so might cause rail failure and potential danger to yourself and the system unit.

1. Read the “Rack Safety Notices” on page 1.
2. Complete a parts inventory.

- Locate the kitting report in an accessory box.
- Ensure that you received all the parts that you ordered. There are two types of rail kits and templates for this system.
- Two rails with cable-management arms
- Two expandable rails with extension brackets

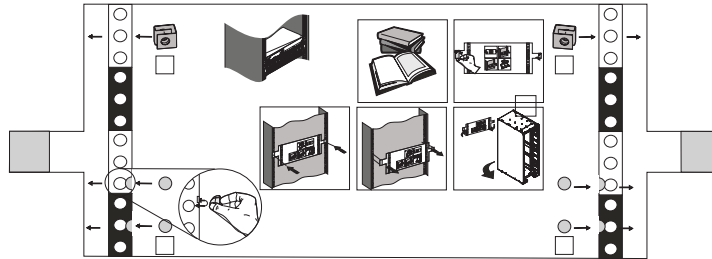

Figure 171. Rack-mounting template for the standard (fixed length) rails.

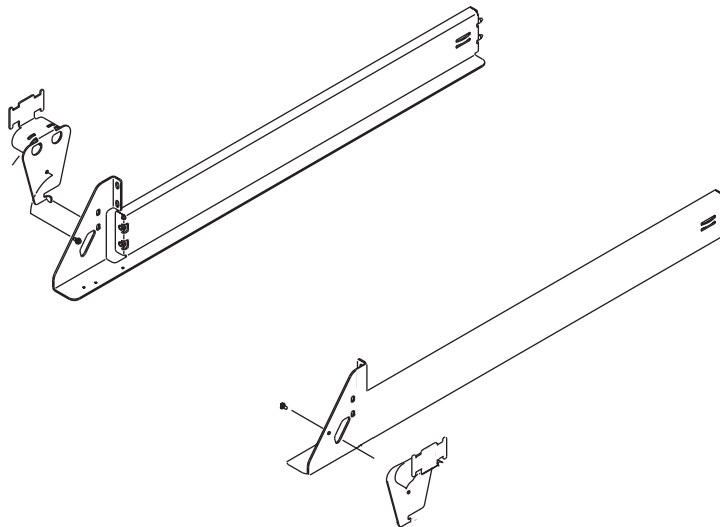
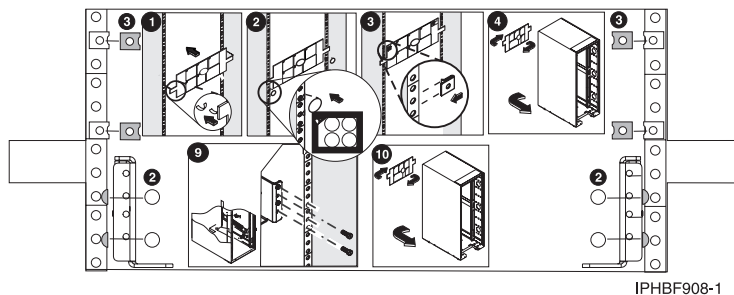

Figure 172. Standard rails with cable-management arms.



IPHBF908-1

Figure 173. Rack-mounting template for the expandable rails.

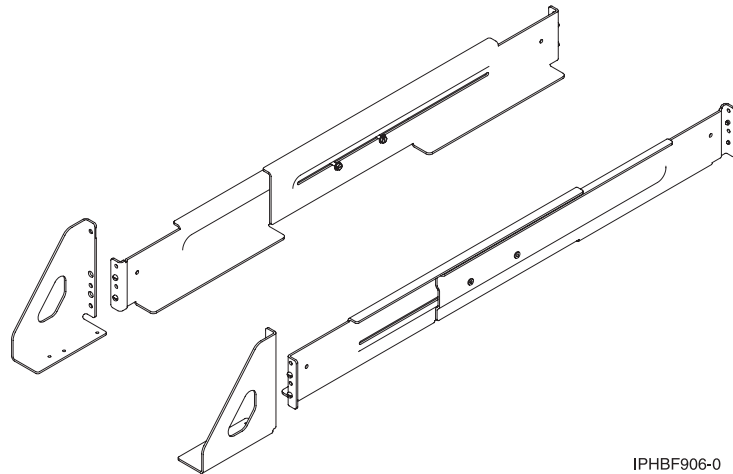

Figure 174. Expandable rails with extension brackets.

Note: There are two versions of the rail kits for the 5790 or 7311-D11.

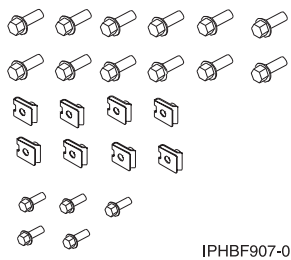

Figure 175. Rack-mounting kit.

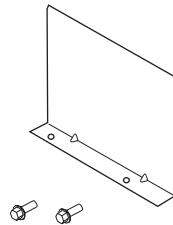

Figure 176. Filler plate and screws.

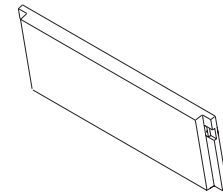

Figure 177. Front bezel.

- If there are incorrect, missing, or damaged parts, contact:
- Your IBM reseller
 - IBM Rochester Manufacturing Automated Information Line at 1-800-300-8751 (United States only).
 - <http://www.ibm.com/planetwide>: Locate your service and support telephone numbers.
3. Ensure that there is an empty slot in an existing shell or that there is enough room in the rack to install a new shell.

Powering off the system and removing power

You might need to power off the system and remove power. Use the procedure in this section to perform this task.

1. Ensure that the system you are attaching to is running the latest level of firmware. For information on checking or upgrading the firmware level or your system, refer to the firmware updates section of your system's installation guide.
2. After ensuring that your firmware is at the latest level, shut down the and power off the system that you are attaching to. For information about shutting down and powering off the system, see the documentation provided with your expansion unit.
3. If you are installing a drawer into an existing shell, continue with "Installing the system" on page 175. Otherwise, refer to "Marking the location using the rack-mounting template" or "Marking the location without a rack-mounting template" on page 167.

Marking the location using the rack-mounting template

You might need to mark the installation location using a rack-mounting template. Use the procedure in this section to perform this task.

If you do not have a rack-mounting template, go to “Marking the location without a rack-mounting template” on page 167.

Note:

1. Read the “Rack Safety Notices” on page 1.
2. The rack-mounting template has printed illustrations located on the front and back of the template. Each illustration is designed to aid you in identifying the EIA (Electronics Industries Association) location holes used when planning to populate your rack. *Do not* use the rack-mounting template without reading and understanding the following steps.
3. Each step must be completed in its entirety. Skipping steps or not following steps in sequence may cause rail failure, resulting in system-drawer damage or bodily injury.
4. Use the front side of the rack-mounting template when installing the hardware on the front of the rack, and the back side of the rack mounting template when installing the hardware on the back of the rack. You can distinguish the front of the template from the back by the step numbers. The steps on the front of the rack-mounting template begin with the number 1.

To install the nut clips into the rack, using the rack-mounting template, complete the following steps:

1. Locate the rack-mounting template, nut clips **B**, self adhesive dots **A**, and rails.
2. Using the rack-mounting template: Each black or white unit on the template is equal to one EIA unit. Each EIA unit consists of three holes. The EIA units illustrated on the template must be aligned with an EIA unit located on the rack. It is not necessary to align like-colored EIA units. For example, a black EIA unit illustrated on the rack-mounting template does not have to be aligned with a black EIA unit located on the rack. A black EIA unit on the rack-mounting template can be aligned with a white EIA unit located on the rack.

To use the rack-mounting template, do the following:

- a. Determine where in the rack to place the drawer. Make note of the EIA location number. Align the black and white strip located on each side of the rack-mounting template with an EIA location on each side of the rack.
- b. Remove the protective coating from each adhesive strip located on the back tabs of the rack-mounting template. Lightly press the template into position onto the rack. Ensure that the rack-mounting template is level.

Note: Make note of the rack EIA location where you mounted the template. You will use the same EIA locations on the back of the rack.

- c. Note the four dots printed on the front side of the template. Attach a self-adhesive dot **A** directly across from the template’s printed dots onto the rack’s EIA strip. These dots determine the placement of the rail-alignment pins.

Note: When attaching the self-adhesive dots, fold the dots around the EIA rail as shown on the template and in the following illustration.

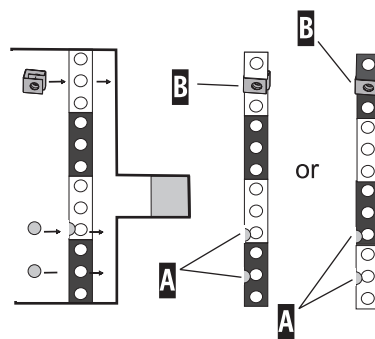

A Folded self-adhesive dot

B Nut clip

Figure 178. Attaching the dots and nut clips for the standard rails.

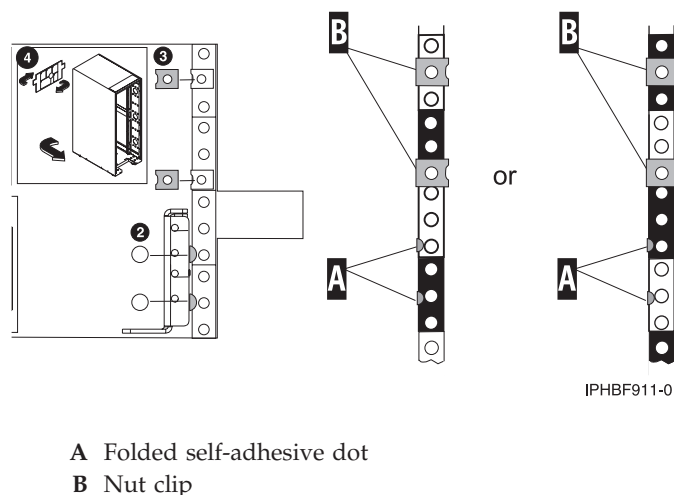

A Folded self-adhesive dot

B Nut clip

Figure 179. Attaching the dots and nut clips for the expandable rails.

- d. Attach the nut clips **B** directly across from the template's printed nut clips onto the rack's EIA strip.
- e. Remove the rack-mounting template from the front of the rack. The four self-adhesive dots and two nut clips have been placed on the front of the rack.
- f. Go to the back of the rack.
- g. Facing the back of the rack, remove the protective coating from each adhesive strip, and attach the backside of the rack-mounting template to the back of the rack. Place the template on the corresponding EIA locations that were noted from the front of the rack.

Note: The steps on the back of the rack-mounting template begin with number 7.

- h. Note the four dots **A** printed on the backside of the template. Attach a self-adhesive dot directly across from the template's printed dots onto the rack's EIA strip.

Note: These dots indicate where the rail retaining screws will be attached.

- i. Attach the nut clips **B** directly across from the templates printed nut clips onto the rack's EIA strip.

Marking the location without a rack-mounting template

You might need to mark the location without a template. Use the procedure in this section to perform this task.

To mark the installation location and install the nut clips into a rack without using the rack-mounting template, complete the following steps:

1. This drawer requires four EIA units. Determine where in the rack to place the drawer and make note of the EIA location numbers.

Note: An EIA section on the rack consists of a grouping of three holes.

The following illustration shows a 1-EIA unit and a 4-EIA unit. Depending on the rack manufacturer, the EIA units may be separated either by color or by a line. The holes along the EIA strip are not evenly spaced. If your rack has no color or line separation between EIAs, assume that each EIA

section begins where the hole spacing is closest together.

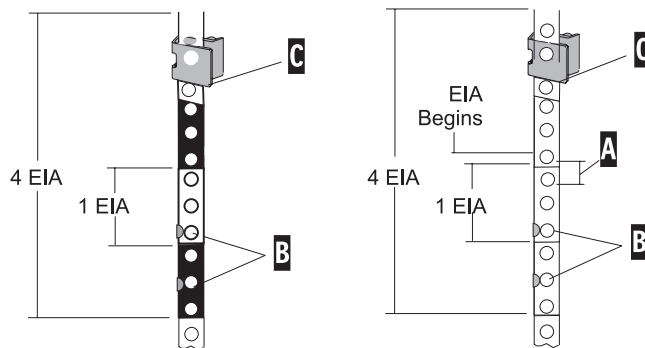
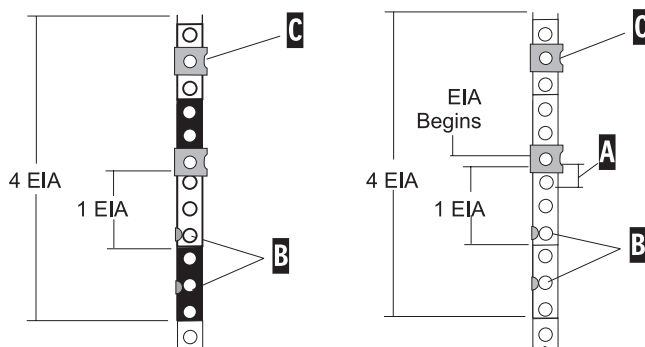

Figure 180. EIA units with the standard rails.

- A EIA hole spacing
- B Self-adhesive dot placement
- C Nut clip



IPHBF910-0

Figure 181. EIA units with the expandable rails.

2. Facing the front of the rack and working from the right side, locate the bottom EIA unit that your drawer will be using and make a note of the EIA location. Place a self-adhesive dot **B** next to the middle hole of this EIA unit and wrap the dot around the rail, or mark the rack where it can be seen from the rear of the rack.

Note: The self-adhesive dots **B** are used to identify the EIA unit holes located on the rack. Alignment pins located on the rail alignment brackets are placed through the identified holes when mounting the rails. If you no longer have any of the dots, use some other form of marking tool to aid you in identifying the hole locations. (for example, marker or pencil).

3. Begin with the hole identified by the dot, or mark, placed in substep 2; count up two holes and place the second dot, or mark the rack where it can be seen from the rear, next to the hole.
4. Begin with the hole identified in substep 3, count up seven holes and place a nut clip. The nut clip **C** aids in securing your drawer to the rack.
5. Repeat steps 2 through 4 on the left side of the rack.
6. Facing the back of the rack and working from the right side, locate the bottom EIA unit that your drawer will be using. Place a supplied self-adhesive dot **B**, or make a mark next to the middle hole of this EIA unit.

7. Begin with the hole identified by the dot, or mark, placed in substep 6, count up two holes and place the second dot, or mark, next to the hole.
8. Begin with the top dot, count up three holes and place a nut clip in that location.
9. Count up two more holes and place a second nut clip in that location.

Installing the standard rails

You might need to install rails into the rack. Use the procedure in this section to perform this task.

To install the standard (fixed length) rails, complete the steps in this section. If you have the expandable rail set, refer to “Installing the expandable rails and extension bracket into the rack.”

1. From the back of the rack, note the position of the two placement dots **B**, or marks, previously installed on the front EIA strips. Install the rack-alignment pins for the left rail into the corresponding EIA holes located in the left front EIA strip **A**.
2. From the back of the rack, align the rails with the two placement dots **B** or marks, previously installed on the front EIA strips. Loosely thread two retaining screws **C** into each rail, at the corresponding EIA strip holes.

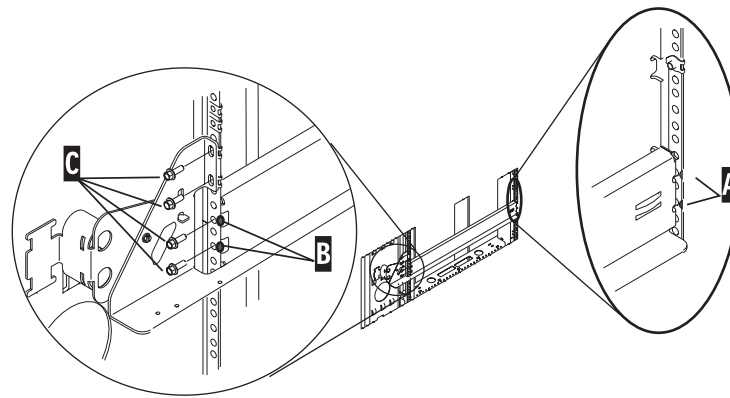

- A two front placement dots per rail
- B two back placement dots per rail
- C four retaining screws per rail

Figure 182. Installing the rails.

3. Loosely thread two retaining screws into the back EIA strips where the nut clips were previously installed.
4. Repeat steps 1 through 3 for the right rail.
5. Tighten all screws.

Installing the expandable rails and extension bracket into the rack

You might need to install rails into the rack. Use the procedure in this section to perform this task.

Attention: Installing the rails in the rack is a complex procedure. To install the rails correctly, you must perform each task in the following order. Failure to do so might cause rail failure and potential danger to yourself and the system unit.

Note: If the system was shipped with the standard rails, refer to “Installing the standard rails.”

To install the expandable rails and extension bracket into the rack, complete the following steps:

1. Loosen the two screws **B** in the middle of both rails **A** to allow each rail to extend.

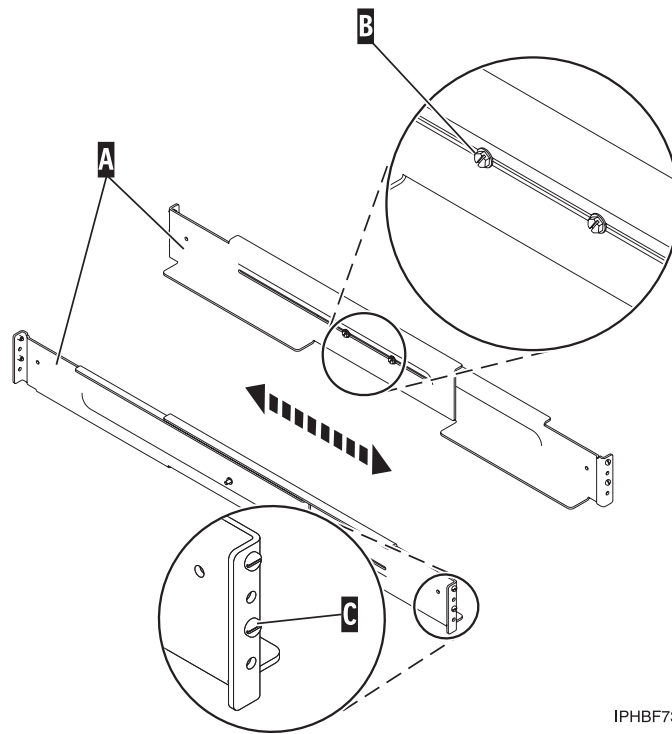

IPHBF731-0

Figure 183. Extending the system rails.

2. Starting at the back of the rack, extend the left rail and insert the rail pins **C** into the marked locations the rack so that it is facing upward (L shape).

Tip: Although the rail installation can be completed by one person, for ease of installation, one person can be positioned at the front of the rack and one person at the back of the rack.

3. From the back of the rack, extend the right rail and insert the rail pins **C** into the marked locations.
4. Move to the front of the rack, extend the left rail and insert the rail pins **C** into the marked locations.
5. Extend the right rail and insert the rail pins **C** into the marked locations.
6. Using one M5 screw **D**, secure the left rail to the front of rack into the lower location **E**.

Important: Do not install a screw in the top location at this time. It will secure the shell to the assembly.

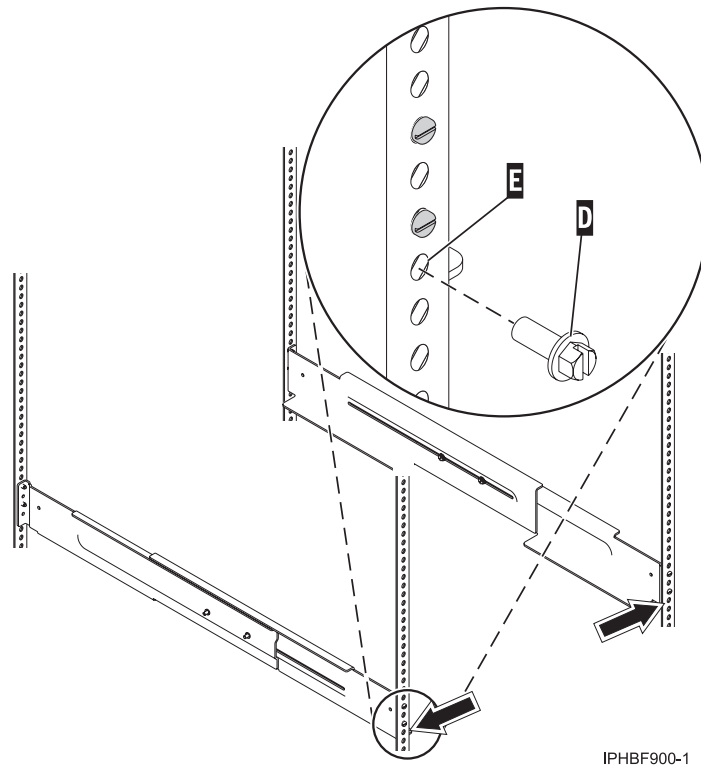

IPHBF900-1

Figure 184. Attaching the system rails to the front of the rack.

7. Using one M5 screw **D**, secure the right rail to the front of the rack into the lower location **E**.
8. Insert two nut clips at the marked location on the front-left rail of the rack.
9. Insert two nut clips at the marked locations on the front-right rail of the rack.
10. Move to the back of the rack and insert two nut clips at the marked locations on the back-left rail of the rack.
11. Insert two nut clips at the marked location on the back-right rail of the rack.
12. Using three M5 screws **G**, secure the extension bracket **F** through the rack and into the left rail.

Note: Each bracket will face inward.

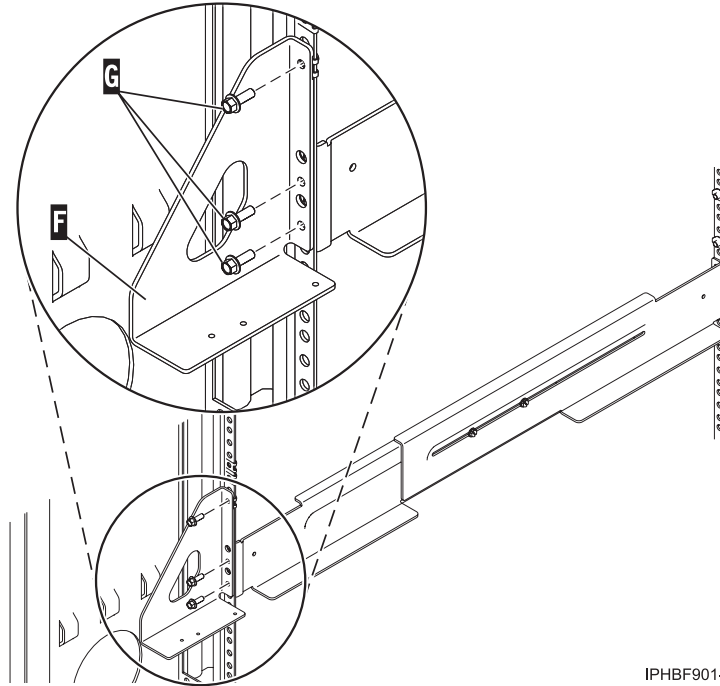

IPHBF901-2

Figure 185. Attaching the extension brackets and rails to the back of the rack.

13. Using three M5 screws **G**, secure the extension bracket **F** through the rack and into the right rail.
14. Tighten the two screws in the middle of the left rail and the two screws in the middle of the right rail. Refer to Figure 184 on page 171.

Installing the shell

You might need to install the shell. Use the procedure in this section to perform this task.

Note: Before installing the shell, ensure that the rails are level from side to side and from front to back.

To install the shell, complete the following steps:

1. From the front of the rack, place the shell **A** on the rails and slide it into the rack.

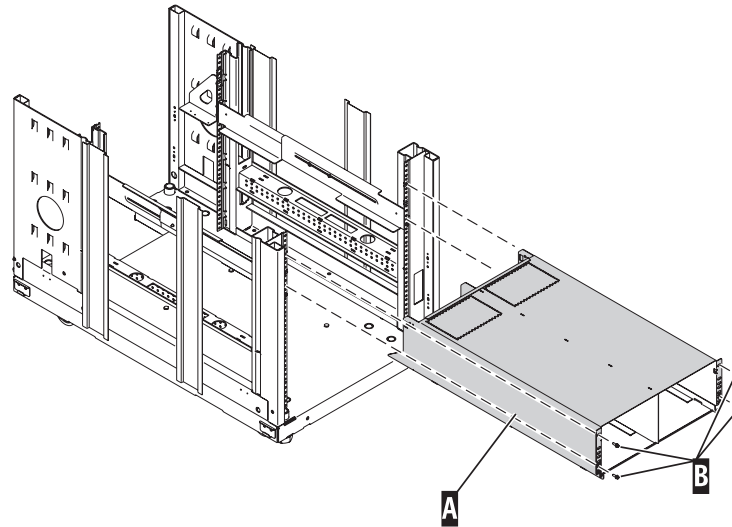

IPHBF903-2

Figure 186. Installing the shell into the rack on the expandable rails.

- A Shell
- B Retaining screws (four)

2. Install and tighten the four retaining screws **B** into the front of the shell, securing the shell **A** to the rack.
3. If you are only installing one drawer, move to the back of the rack and secure the shell **A** with the retaining screw **C**. Ensure screw **C** is attached to the slot of the shell opposite of the slot in which you intend to place the system drawer.

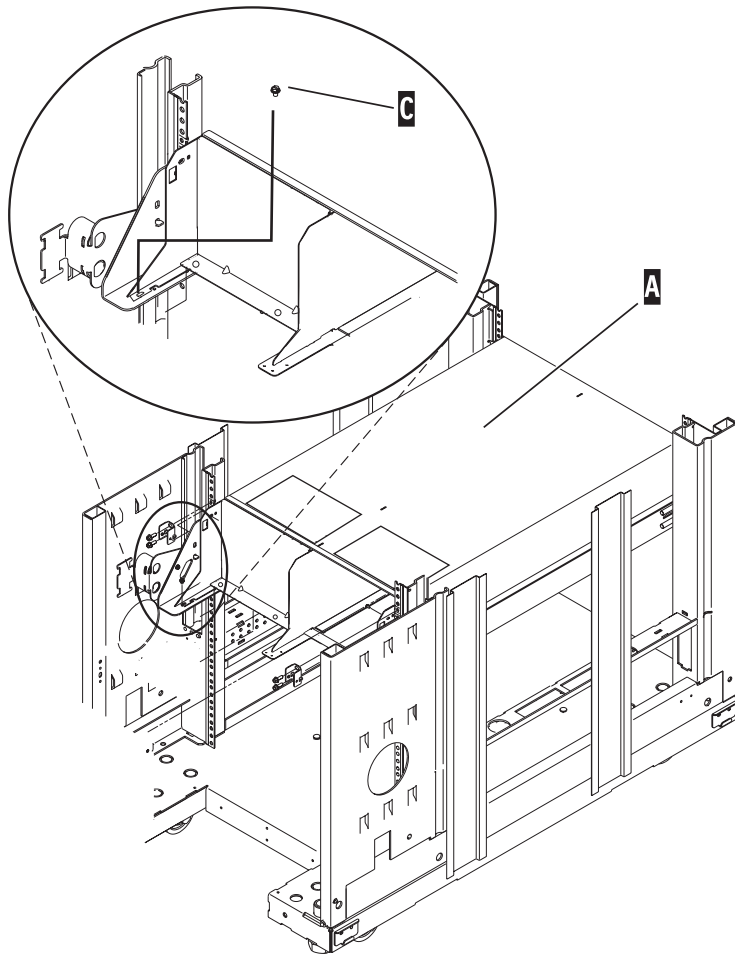
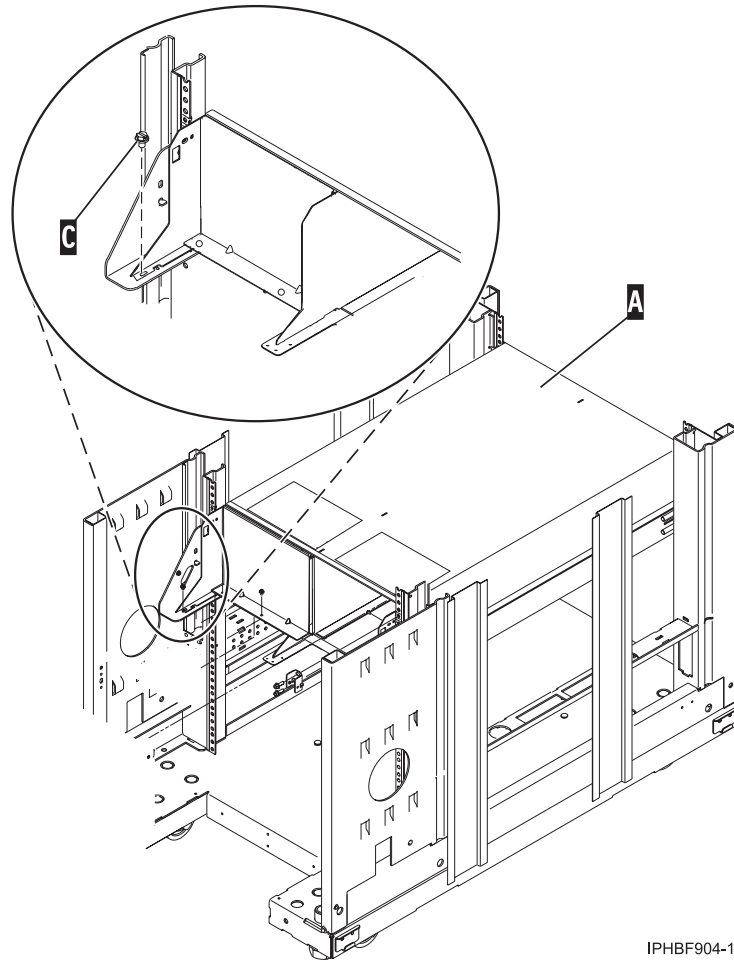

Figure 187. Securing the shell to the rack with the standard rails.

- A Shell
- C Retaining screw



IPHBF904-1

Figure 188. Securing the shell to the rack with the expandable rails.

- A Shell
- C Retaining screw

Installing the system

You might need to install the system into the rack. Use the procedure in this section to perform this task.

To install the system into a rack, complete the following steps:

1. Move to the back of the rack.
2. If you are installing a drawer **D** into an existing shell **C**, remove the two filler plate screws **A** and the filler plate **B**.

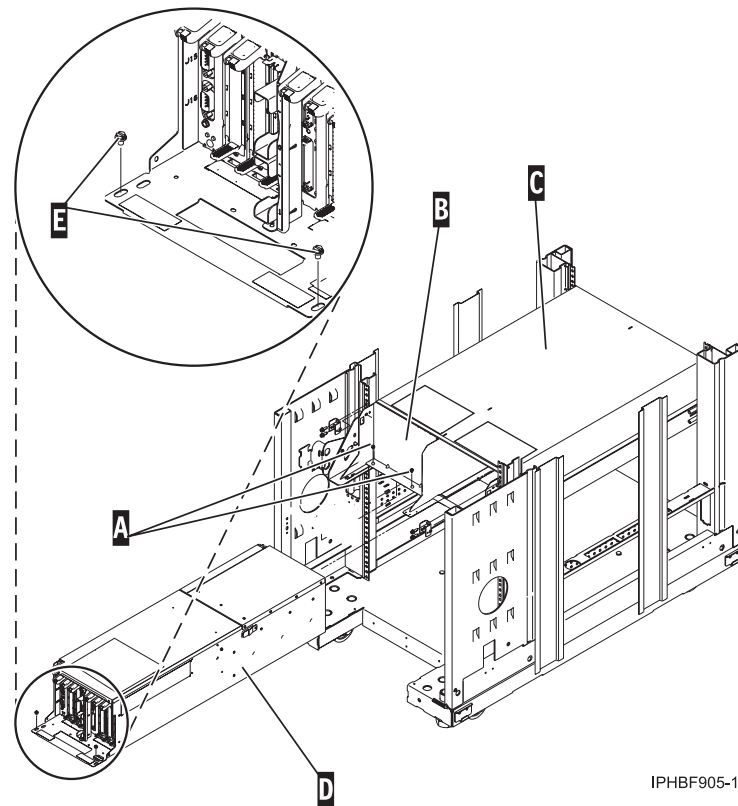

IPHBF905-1

- A Filler plate screws
- B Filler plate
- C Shell
- D Drawer
- E Drawer screws

Figure 189. Removing the filler plate.

3. Carefully move any existing cables that are blocking the drawer location.
4. Slide the drawer **D** into the shell.
5. Install and tighten the two drawer screws **E**, securing the drawer to the shell.
6. If you are installing two drawers, repeat substeps 1 through 5. If there is only one drawer installed in the shell, ensure that the filler plate **B** is installed in the blank slot.

Attaching the RIO/HSL, power controller (SPCN), and power cables

You might need to attach cables to the system. Use the procedure in this section to perform this task.

For information about attaching the cables to your system, refer to the documentation provided with your system.

Note: For information about connecting power cables to the power distribution units (PDUs) in the rack, refer to [installrack.htm](#).

To attach the RIO/HSL, power controller (SPCN), and power cables, route the cables over the cable management bracket and secure them with the hook-and-loop fastener.

Powering on the system

You might need to power on the system. For information about powering on the system, refer to system's installation guide.

Related information

You might need to use the related procedures. This section includes procedures so that you can perform these tasks.

The following procedures are related to rack installation.

Determine power cord, plug, and receptacle type

To determine what power cord, plug, and receptacle type your server or system requires, you need to know the country or region in which your server or system will reside, your server or system model, and the voltage and amperage of your power supply.

With this information, you can determine your type through these tables:

- Power cords, plugs, and receptacles: By country or region
- Power cords, plugs, and receptacles: By model
- Power cords, plugs, and receptacles: By voltage and amperage
- Power cord features
- Power load calculating for 7188 and 9188 power distribution units

See Modification of IBM Cords for recommendations regarding the alteration of power cords.

Tip: Print the **Plug and receptacle type** table for your server or system and give it to your electrician. The table contains information needed to install the proper receptacle for your system expansion unit.

The server or system and all of the expansion units and attached equipment will require an isolated power supply. This means, it must have its own circuit. Use an uninterruptible power supply to help protect both the server and its data.

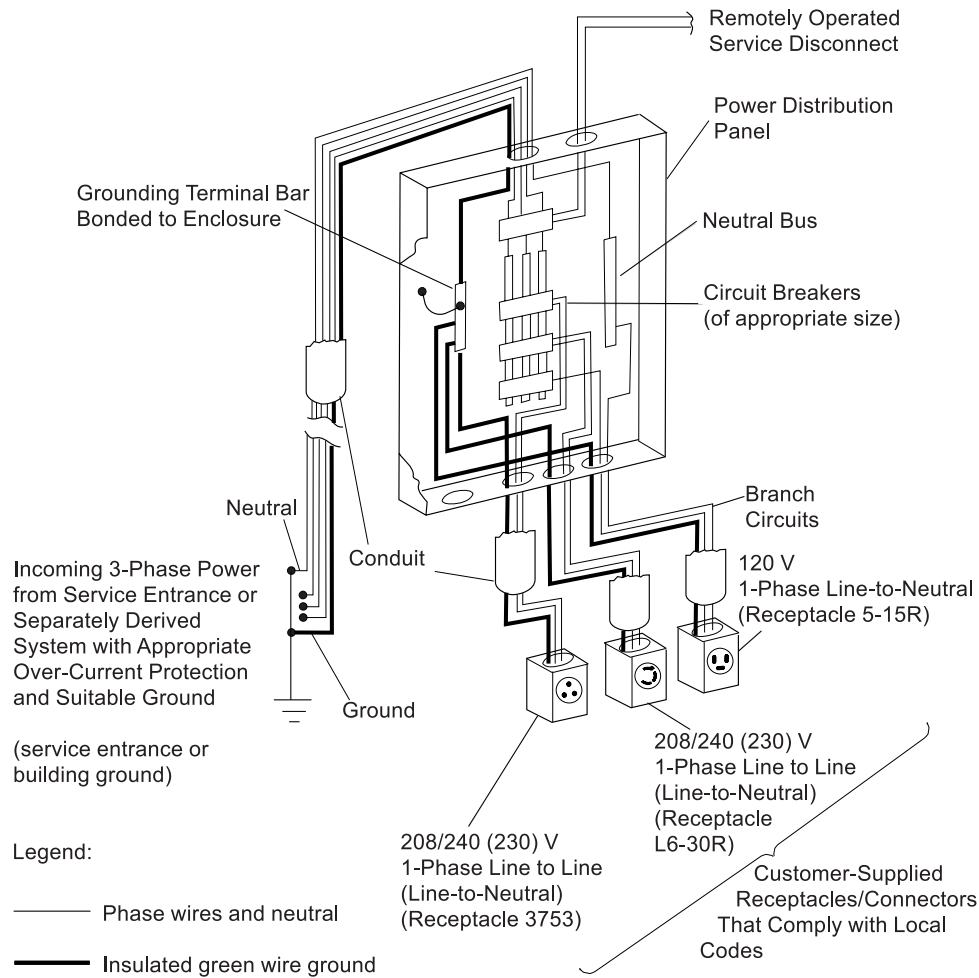

- Note:** 1. The receptacles must match the plug types ordered on your data processing equipment.
 2. For loads requiring a neutral, attach computer/data processing equipment only.

RV2C031-3

Reconnecting cables to the system

You might need to reconnect the cables to the system. Use the procedure in this section to perform this task.

After you have installed the system unit into the rack and attached the cable management arm, you will need to reconnect the power cords and cables.

1. Plug in the power cord for the system unit.

Note: The system might be equipped with two power supplies, each with its own power cord.

2. Route the other cables that you disconnected through the cable-management arm and reconnect them to your server. See *Cabling your server*.
3. Reconnect the HMC, if you have one for this system. See *Adding an HMC console*.
4. Power on the system unit and any devices connected to the system unit.

Connecting drawer and device cables

You might need to connect cables. Use the procedure in this section to perform this task.

Most racks are pre-configured at the factory with all drawer and device cables installed.

If any head protectors are installed in the diskette drives, remove them.

If you need to install drawer and device cables, follow the installation instructions that were provided with the drawer or device being installed.

- For ac devices, plug the device power distribution bus cables into the rack power distribution bus.
- For dc devices, plug the device cables into the rack power distribution panel.

Related topic: “Attaching the rack doors” on page 29

Appendix. Accessibility features

Accessibility features help users who have a physical disability, such as restricted mobility or limited vision, to use information technology products successfully.

The following list includes the major accessibility features:

- Keyboard-only operation
- Interfaces that are commonly used by screen readers
- Keys that are tactilely discernible and do not activate just by touching them
- Industry-standard devices for ports and connectors
- The attachment of alternative input and output devices

IBM and accessibility

See the IBM Accessibility Center at <http://www.ibm.com/able/> for more information about the commitment that IBM has to accessibility.

Notices

This information was developed for products and services offered in the U.S.A.

The manufacturer may not offer the products, services, or features discussed in this document in other countries. Consult the manufacturer's representative for information on the products and services currently available in your area. Any reference to the manufacturer's product, program, or service is not intended to state or imply that only that product, program, or service may be used. Any functionally equivalent product, program, or service that does not infringe any intellectual property right of the manufacturer may be used instead. However, it is the user's responsibility to evaluate and verify the operation of any product, program, or service.

The manufacturer may have patents or pending patent applications covering subject matter described in this document. The furnishing of this document does not give you any license to these patents. You can send license inquiries, in writing, to the manufacturer.

The following paragraph does not apply to the United Kingdom or any other country where such provisions are inconsistent with local law: THIS INFORMATION IS PROVIDED "AS IS" WITHOUT WARRANTY OF ANY KIND, EITHER EXPRESS OR IMPLIED, INCLUDING, BUT NOT LIMITED TO, THE IMPLIED WARRANTIES OF NON-INFRINGEMENT, MERCHANTABILITY OR FITNESS FOR A PARTICULAR PURPOSE. Some states do not allow disclaimer of express or implied warranties in certain transactions, therefore, this statement may not apply to you.

This information could include technical inaccuracies or typographical errors. Changes are periodically made to the information herein; these changes will be incorporated in new editions of the publication. The manufacturer may make improvements and/or changes in the product(s) and/or the program(s) described in this publication at any time without notice.

Any references in this information to Web sites not owned by the manufacturer are provided for convenience only and do not in any manner serve as an endorsement of those Web sites. The materials at those Web sites are not part of the materials for this product and use of those Web sites is at your own risk.

The manufacturer may use or distribute any of the information you supply in any way it believes appropriate without incurring any obligation to you.

Any performance data contained herein was determined in a controlled environment. Therefore, the results obtained in other operating environments may vary significantly. Some measurements may have been made on development-level systems and there is no guarantee that these measurements will be the same on generally available systems. Furthermore, some measurements may have been estimated through extrapolation. Actual results may vary. Users of this document should verify the applicable data for their specific environment.

Information concerning products not produced by this manufacturer was obtained from the suppliers of those products, their published announcements or other publicly available sources. This manufacturer has not tested those products and cannot confirm the accuracy of performance, compatibility or any other claims related to products not produced by this manufacturer. Questions on the capabilities of products not produced by this manufacturer should be addressed to the suppliers of those products.

All statements regarding the manufacturer's future direction or intent are subject to change or withdrawal without notice, and represent goals and objectives only.

The manufacturer's prices shown are the manufacturer's suggested retail prices, are current and are subject to change without notice. Dealer prices may vary.

This information is for planning purposes only. The information herein is subject to change before the products described become available.

This information contains examples of data and reports used in daily business operations. To illustrate them as completely as possible, the examples include the names of individuals, companies, brands, and products. All of these names are fictitious and any similarity to the names and addresses used by an actual business enterprise is entirely coincidental.

If you are viewing this information in softcopy, the photographs and color illustrations may not appear.

The drawings and specifications contained herein shall not be reproduced in whole or in part without the written permission of the manufacturer.

The manufacturer has prepared this information for use with the specific machines indicated. The manufacturer makes no representations that it is suitable for any other purpose.

The manufacturer's computer systems contain mechanisms designed to reduce the possibility of undetected data corruption or loss. This risk, however, cannot be eliminated. Users who experience unplanned outages, system failures, power fluctuations or outages, or component failures must verify the accuracy of operations performed and data saved or transmitted by the system at or near the time of the outage or failure. In addition, users must establish procedures to ensure that there is independent data verification before relying on such data in sensitive or critical operations. Users should periodically check the manufacturer's support websites for updated information and fixes applicable to the system and related software.

Trademarks

The following terms are trademarks of International Business Machines Corporation in the United States, other countries, or both:

AIX

AIX 5L

eServer

i5/OS

IBM

OpenPower

POWER

pSeries

System i

System p

Other company, product or service names may be trademarks or service marks of others.

Electronic emission notices

Class A Notices

The following Class A statements apply to the IBM System i models and IBM System p servers with the exception of those that are specifically identified as Class B.

Federal Communications Commission (FCC) statement

Note: This equipment has been tested and found to comply with the limits for a Class A digital device, pursuant to Part 15 of the FCC Rules. These limits are designed to provide reasonable protection against harmful interference when the equipment is operated in a commercial environment. This equipment generates, uses, and can radiate radio frequency energy and, if not installed and used in accordance with the instruction manual, may cause harmful interference to radio communications. Operation of this equipment in a residential area is likely to cause harmful interference, in which case the user will be required to correct the interference at his own expense.

Properly shielded and grounded cables and connectors must be used in order to meet FCC emission limits. IBM is not responsible for any radio or television interference caused by using other than recommended cables and connectors or by unauthorized changes or modifications to this equipment. Unauthorized changes or modifications could void the user's authority to operate the equipment.

This device complies with Part 15 of the FCC rules. Operation is subject to the following two conditions: (1) this device may not cause harmful interference, and (2) this device must accept any interference received, including interference that may cause undesired operation.

Industry Canada Compliance Statement

This Class A digital apparatus complies with Canadian ICES-003.

Avis de conformité à la réglementation d'Industrie Canada

Cet appareil numérique de la classe A respecte est conforme à la norme NMB-003 du Canada.

European Community Compliance Statement

This product is in conformity with the protection requirements of EU Council Directive 2004/108/EC on the approximation of the laws of the Member States relating to electromagnetic compatibility. IBM cannot accept responsibility for any failure to satisfy the protection requirements resulting from a non-recommended modification of the product, including the fitting of non-IBM option cards.

This product has been tested and found to comply with the limits for Class A Information Technology Equipment according to European Standard EN 55022. The limits for Class A equipment were derived for commercial and industrial environments to provide reasonable protection against interference with licensed communication equipment.

European Community contact:
IBM Technical Regulations
Pascalstr. 100, Stuttgart, Germany 70569
Tele: 0049 (0)711 785 1176
Fax: 0049 (0)711 785 1283
E-mail: tjahn@de.ibm.com

Warning: This is a Class A product. In a domestic environment, this product may cause radio interference in which case the user may be required to take adequate measures.

VCCI Statement - Japan

この装置は、情報処理装置等電波障害自主規制協議会（VCCI）の基準に基づくクラスA情報技術装置です。この装置を家庭環境で使用すると電波妨害を引き起こすことがあります。この場合には使用者が適切な対策を講ずるよう要求されることがあります。

The following is a summary of the VCCI Japanese statement in the box above.

This product is a Class A Information Technology Equipment and conforms to the standards set by the Voluntary Control Council for Interference by Information Technology Equipment (VCCI). In a domestic environment, this product may cause radio interference, in which case the user may be required to take adequate measures.

Electromagnetic Interference (EMI) Statement - People's Republic of China

声 明

此为A级产品,在生活环境
中,该产品可能会造成无线电干
扰。在这种情况下,可能需要用
户对其干扰采取切实可行的措
施。

Declaration: This is a Class A product. In a domestic environment this product may cause radio interference in which case the user may need to perform practical action.

Electromagnetic Interference (EMI) Statement - Taiwan

警告使用者：

這是甲類的資訊產品，在居住的環境中使用時，可能會造成射頻干擾，在這種情況下，使用者會被要求採取某些適當的對策。

The following is a summary of the EMI Taiwan statement above.

Warning: This is a Class A product. In a domestic environment this product may cause radio interference in which case the user will be required to take adequate measures.

IBM Taiwan Contact Information:

台灣IBM 產品服務聯絡方式：
台灣國際商業機器股份有限公司
台北市松仁路7號3樓
電話：0800-016-888

Electromagnetic Interference (EMI) Statement - Korea

이 기기는 업무용으로 전자파적합등록을 한 기기이오니 판매자 또는 사용자는 이점을 주의하시기 바라며, 만약 잘못 판매 또는 구입하였을 때에는 가정용으로 교환하시기 바랍니다.

Please note that this equipment has obtained EMC registration for commercial use. In the event that it has been mistakenly sold or purchased, please exchange it for equipment certified for home use.

Germany Compliance Statement

Deutschsprachiger EU Hinweis: Hinweis für Geräte der Klasse A EU-Richtlinie zur Elektromagnetischen Verträglichkeit

Dieses Produkt entspricht den Schutzanforderungen der EU-Richtlinie 2004/108/EG zur Angleichung der Rechtsvorschriften über die elektromagnetische Verträglichkeit in den EU-Mitgliedsstaaten und hält die Grenzwerte der EN 55022 Klasse A ein.

Um dieses sicherzustellen, sind die Geräte wie in den Handbüchern beschrieben zu installieren und zu betreiben. Des Weiteren dürfen auch nur von der IBM empfohlene Kabel angeschlossen werden. IBM übernimmt keine Verantwortung für die Einhaltung der Schutzanforderungen, wenn das Produkt ohne Zustimmung der IBM verändert bzw. wenn Erweiterungskomponenten von Fremdherstellern ohne Empfehlung der IBM gesteckt/eingebaut werden.

EN 55022 Klasse A Geräte müssen mit folgendem Warnhinweis versehen werden:

"Warnung: Dieses ist eine Einrichtung der Klasse A. Diese Einrichtung kann im Wohnbereich Funk-Störungen verursachen; in diesem Fall kann vom Betreiber verlangt werden, angemessene Maßnahmen zu ergreifen und dafür aufzukommen."

Deutschland: Einhaltung des Gesetzes über die elektromagnetische Verträglichkeit von Geräten

Dieses Produkt entspricht dem "Gesetz über die elektromagnetische Verträglichkeit von Geräten (EMVG)". Dies ist die Umsetzung der EU-Richtlinie 2004/108/EG in der Bundesrepublik Deutschland.

Zulassungsbescheinigung laut dem Deutschen Gesetz über die elektromagnetische Verträglichkeit von Geräten (EMVG) (bzw. der EMC EG Richtlinie 2004/108/EG) für Geräte der Klasse A.

Dieses Gerät ist berechtigt, in Übereinstimmung mit dem Deutschen EMVG das EG-Konformitätszeichen - CE - zu führen.

Verantwortlich für die Konformitätserklärung nach des EMVG ist die IBM Deutschland GmbH, 70548 Stuttgart.

Generelle Informationen:

Das Gerät erfüllt die Schutzanforderungen nach EN 55024 und EN 55022 Klasse A.

Electromagnetic Interference (EMI) Statement - Russia

ВНИМАНИЕ! Настоящее изделие относится к классу А.
В жилых помещениях оно может создавать радиопомехи, для снижения которых необходимы дополнительные меры

Class B Notices

The following Class B statements apply to model 9111-520 (stand-alone version), 9131-52A (stand-alone version), 7047-185 and the 9111-285.

Federal Communications Commission (FCC) statement

Note: This equipment has been tested and found to comply with the limits for a class B digital device, pursuant to Part 15 of the FCC Rules. These limits are designed to provide reasonable protection against harmful interference in a residential installation. This equipment generates, uses, and can radiate radio frequency energy and, if not installed and used in accordance with the instructions, may cause harmful interference to radio communications. However, there is no guarantee that interference will not occur in a particular installation. If this equipment does cause harmful interference to radio or television reception, which can be determined by turning the equipment off and on, the user is encouraged to try to correct the interference by one or more of the following measures:

- Reorient or relocate the receiving antenna.
- Increase the separation between the equipment and receiver.
- Connect the equipment into an outlet on a circuit different from that to which the receiver is connected.
- Consult an IBM authorized dealer or service representative for help.

Properly shielded and grounded cables and connectors must be used in order to meet FCC emission limits. Proper cables and connectors are available from IBM authorized dealers. IBM is not responsible for any radio or television interference caused by using other than recommended cables or connectors or by unauthorized changes or modifications to this equipment. Unauthorized changes or modifications could void the user's authority to operate the equipment.

This device complies with Part 15 of the FCC Rules. Operation is subject to the following two conditions: (1) this device may not cause harmful interferences, and (2) this device must accept any interferences received, including interference that may cause undesired operation.

Industry Canada Compliance Statement

This Class B digital apparatus complies with Canadian ICES-003.

Avis de conformité à la réglementation d'Industrie Canada

Cet appareil numérique de la classe B respecte est conforme à la norme NMB-003 du Canada.

European Community Compliance Statement

This product is in conformity with the protection requirements of EC Council Directive 2004/108/EC on the approximation of the laws of the Member States relating to electromagnetic compatibility. IBM cannot accept responsibility for any failure to satisfy the protection requirements resulting from a non-recommended modification of the product, including the fitting of non-IBM option cards.

This product has been tested and found to comply with the limits for Class B Information Technology Equipment according to CISPR 22 / European Standard EN 55022. The limits for Class B equipment were derived for typical residential environments to provide reasonable protection against interference with licensed communication devices.

Properly shielded and grounded cables and connectors must be used in order to reduce the potential for causing interference to radio and TV communications and to other electrical or electronic equipment. Such cables and connectors are available from IBM authorized dealers. IBM cannot accept responsibility for an interference caused by using other than recommended cables and connectors.

European Community contact:
IBM Technical Regulations
Pascalstr. 100, Stuttgart, Germany 70569
Tele: 0049 (0)711 785 1176
Fax: 0049 (0)711 785 1283
E-mail: tjahn@de.ibm.com

VCCI Statement - Japan

この装置は、情報処理装置等電波障害自主規制協議会（VCCI）の基準に基づくクラスB情報技術装置です。この装置は、家庭環境で使用することを目的としていますが、この装置がラジオやテレビジョン受信機に近接して使用されると、受信障害を引き起こすことがあります。
取扱説明書に従って正しい取り扱いをして下さい。

The following is a summary of the VCCI Japanese statement in the box above.

This is a Class B product based on the standard of the Voluntary Control Council for Interference by Information Technology Equipment (VCCI). If this equipment is used in a domestic environment, radio disturbance may arise. When such trouble occurs, the user may be required to take corrective actions.

IBM Taiwan Product Service Contact Information

台灣IBM 產品服務聯絡方式：
台灣國際商業機器股份有限公司
台北市松仁路7號3樓
電話：0800-016-888

Electromagnetic Interference (EMI) Statement - Korea

이 기기는 가정용으로 전자파적합등록을 한 기기로서 주거 지역에서는 물론 모든 지역에서 사용할 수 있습니다.

Radio Protection for Germany

Deutschsprachiger EU Hinweis: Hinweis für Geräte der Klasse B EU-Richtlinie zur Elektromagnetischen Verträglichkeit

Dieses Produkt entspricht den Schutzanforderungen der EU-Richtlinie 2004/108/EG zur Angleichung der Rechtsvorschriften über die elektromagnetische Verträglichkeit in den EU-Mitgliedsstaaten und hält die Grenzwerte der EN 55022 Klasse B ein.

Um dieses sicherzustellen, sind die Geräte wie in den Handbüchern beschrieben zu installieren und zu betreiben. Des Weiteren dürfen auch nur von der IBM empfohlene Kabel angeschlossen werden. IBM übernimmt keine Verantwortung für die Einhaltung der Schutzanforderungen, wenn das Produkt ohne Zustimmung der IBM verändert bzw. wenn Erweiterungskomponenten von Fremdherstellern ohne Empfehlung der IBM gesteckt/eingebaut werden.

Deutschland: Einhaltung des Gesetzes über die elektromagnetische Verträglichkeit von Geräten

Dieses Produkt entspricht dem "Gesetz über die elektromagnetische Verträglichkeit von Geräten (EMVG)". Dies ist die Umsetzung der EU-Richtlinie 2004/108/EG in der Bundesrepublik Deutschland.

Zulassungsbescheinigung laut dem Deutschen Gesetz über die elektromagnetische Verträglichkeit von Geräten (EMVG) (bzw. der EMC EG Richtlinie 2004/108/EG) für Geräte der Klasse B.

Dieses Gerät ist berechtigt, in Übereinstimmung mit dem Deutschen EMVG das EG-Konformitätszeichen - CE - zu führen.

Verantwortlich für die Konformitätserklärung nach des EMVG ist die IBM Deutschland GmbH, 70548 Stuttgart.

Generelle Informationen:

Das Gerät erfüllt die Schutzanforderungen nach EN 55024 und EN 55022 Klasse B.



Printed in USA